



The following Motions and Documents were considered by the GFC Facilities Development Committee at its Thursday, November 26, 2015 meeting:

Agenda Title: **Research and Collections Resource Facility (RCRF): Schematic Design Report**

CARRIED MOTION: THAT the GFC Facilities Development Committee approve, under delegated authority from General Faculties Council, and on the recommendation of Planning and Project Delivery, the proposed Research and Collections and Resource Facility (RCRF) – Schematic Design Report (as set forth in Attachment 2) as the basis for further planning.

Final Item: 7

OUTLINE OF ISSUE

Agenda Title: **Research and Collections Resource Facility (RCRF): Schematic Design Report**

Motion: THAT the GFC Facilities Development Committee approve, under delegated authority from General Faculties Council, and on the recommendation of Planning and Project Delivery, the proposed Research and Collections and Resource Facility (RCRF) – Schematic Design Report (as set forth in Attachment 2) as the basis for further planning.

Item

Action Requested	<input checked="" type="checkbox"/> Approval <input type="checkbox"/> Recommendation <input type="checkbox"/> Discussion/Advice <input type="checkbox"/> Information
Proposed by	Ben Louie, University Architect, Facilities and Operations
Presenter	Gerald Beasley, Vice-Provost and Chief Librarian, Libraries; Kelly Hopkin, Senior Campus Planner (Architecture), Office of the University Architect, Facilities and Operations; Janet Koshuta, Principal, HFKS Architecture
Subject	Research and Collections Resource Facility (RCRF) – Schematic Design Report

Details

Responsibility	Vice-President (Facilities and Operations)
The Purpose of the Proposal is (please be specific)	To obtain approval for the schematic design report for RCRF; a new, purpose-built facility on South Campus. The facility will provide the required process and high-density storage capacity including expansion space for archival and library collections in an environmentally appropriate climate.
The Impact of the Proposal is	To provide needed infrastructure to ensure the collections of the university are maintained in a safe environment; easily accessible to the academy and all its affiliated institutions; and expandable to accommodate the short and mid-term needs of the facility, as well as the long term vision.
Replaces/Revises (e.g., policies, resolutions)	N/A
Timeline/Implementation Date	<ul style="list-style-type: none"> • GFC Facilities Development Committee – RCRF Design Development Report (for approval) – January 28, 2016 • Phased construction to start – Spring 2016 • Construction completion with move-in and occupancy to follow – late Summer 2017
Estimated Cost	N/A
Sources of Funding	N/A
Notes	N/A

Alignment/Compliance

Alignment with Guiding Documents	<i>Dare to Discover, Dare to Deliver</i> ; Long Range Development Plan (LRDP); University of Alberta Comprehensive Institutional Plan (CIP)
Compliance with Legislation, Policy and/or Procedure Relevant to the Proposal (please quote legislation and include identifying section numbers)	1. Post-Secondary Learning Act (PSLA): The PSLA gives GFC responsibility, subject to the authority of the Board of Governors, over academic affairs (Section 26(1)) and provides that GFC may make recommendations to the Board of Governors on a building program and related matters (Section 26(1) (o)). Section 18(1) of the PSLA give the Board of Governors the authority to make any bylaws “appropriate for the management, government and control of the university buildings and land.” Section 19 of the <i>Act</i> requires that the Board “consider the

FINAL Item No. 7

	<p>recommendations of the general faculties council, if any, on matters of academic import prior to providing for (a) the support and maintenance of the university, (b) the betterment of existing buildings, (c) the construction of any new buildings the board considers necessary for the purposes of the university [and] (d) the furnishing and equipping of the existing and newly erected buildings [.] [...]” Section 67(1) of the Act governs the terms under which university land may be leased.</p> <p>2. GFC Facilities Development Committee (FDC) Terms of Reference – Section 3. Mandate of the Committee: “[...]”</p> <p>2. Delegation of Authority</p> <p>Notwithstanding anything to the contrary in the terms of reference above, the Board of Governors and General Faculties Council have delegated to the Facilities Development Committee the following powers and authority:</p> <p>A. Facilities</p> <p>1. To approve proposed General Space Programmes (Programs) for academic units.</p> <p>2. (i) To approve proposals concerning the design and use of all new facilities and the repurposing of existing facilities and to routinely report these decisions for information to the Board of Governors.</p> <p>(ii) In considering such proposals, GFC FDC may provide advice, upon request, to the Provost and Vice-President (Academic), Vice-President (Facilities and Operations), and/or the University Architect (or their respective delegates) on the siting of such facilities. (GFC SEP 29 2003)</p> <p>B. Other Matters</p> <p>The Chair of FDC will bring forward to FDC items where the Office of the Provost and Vice-President (Academic) and/or the Office of the Vice-President (Facilities and Operations), in consultation with other units or officers of the University, is seeking the advice of the Committee. [...]</p> <p>3. UAPPOL Space Management Policy and Space Management Procedure: The respective roles of GFC FDC and the Vice-President (Facilities and Operations) with regard to institutional space management are set out in this Board-approved Policy and attendant Procedure.</p> <p>To access this policy suite on line, go to: www.uappol.ualberta.ca.</p>
--	--

Routing (Include meeting dates)

<p>Consultative Route (parties who have seen the proposal and in what capacity)</p>	<ul style="list-style-type: none"> • Vice-Provost and Chief Librarian • Associate Vice-President (Planning and Project Delivery) • Community Open Houses – July 27, 2015 and November 24, 2015 • Courtesy review meeting with Dean, Faculty of Agricultural, Life and Environmental Sciences and Dean, Faculty of Physical Education and Recreation - November 20, 2015
---	---

FINAL Item No. 7

Approval Route (Governance) (including meeting dates)	GFC Facilities Development Committee (November 26, 2015) – for approval
Final Approver	GFC Facilities Development Committee

Attachments:

1. Attachment 1 (3 pages) :Briefing Note
2. Attachment 2 (77 pages) : University of Alberta Research and Collections Resource Facility – Schematic Design Report (November 9, 2015)

Prepared by: Kelly Hopkin, Senior Campus Planner (Architecture), Office of the University Architect, Planning and Project Delivery, Facilities and Operations, hopkin@ualberta.ca

Revised: 12/23/2015

Office of the University Architect
Planning and Project Delivery
Facilities and Operations

Research and Collections Resource Facility (RCRF) – Schematic Design Report

Background

Opened in 1994, the Book and Record Depository (BARD) is a high-density library storage facility that houses less frequently accessed library materials, research collections, and the University of Alberta Archives. The facility holds mostly books and journal volumes, but also microfilm, maps, audio discs, manuscripts, archives, and other formats normally collected by research libraries. The staff at BARD receives, process, and creates machine-readable records for newly deposited materials, provide circulation, and document delivery services. Together these constitute one of Canada's most significant, academic, and cultural resources. BARD has been located in the leased and adapted commercial facility located off of the University of Alberta (U of A) campus. The lease expires in 2017 and the projected growth of BARD cannot be appropriately accommodated at that location.

The project has been approved by the appropriate committees ie. BFPC on November 2014 and BG on December 2014. The functional program was approved by GFC FDC on March 2015 and presentation of site options and concept plan to GFC FDC on July 2015 for discussion and advice.

In July 2015, a Design Build (DB) Team, led by Stuart Olson, was retained to proceed to Phase 1 of this project, namely the design phases. Phase 1, defined as the Validation Stage/Schematic Design in the original Request for Proposal documents, is to “translate the project requirements into space parameters, to explore preliminary design options and analyze them against priorities and program objectives”.

The goal of the project is to replace the existing BARD with a new, purpose-built Research and Collections Resource Facility (RCRF) to be built on South Campus. The BARD collections, and co-located with the University Archives, will be relocated and augmented by the volumes transferred off North Campus, to ease campus space pressure and accommodate new technological functions of Library Services.

The new RCRF facility will:

- provide proper environment in which to store materials protecting the irreplaceable collection and the University Archives;
- lower risk of stored material damage, decreasing the liability exposure;
- provide the required capacity and afford expansion space and future growth for related or complimentary use occupancies;
- offer improved access from the U of A campuses, including use of public transportation; and
- align with guiding documents of: Dare to Discover, Dare to Deliver, and Long Range Development Plan (LRDP), updated June 2013.

The RCRF objectives are:

- accommodate up to 5.1M volumes capacity to grow from the current 3.1M BARD print volumes projected over the next 20 years, and the backlog of unprocessed materials to the collection;

- accommodate up to 1.0M* items relocated from North Campus to free up valuable space for academic requirements;
- accommodate the University Archives, currently co-located with BARD;
- provide an appropriate, functional, and welcoming space for staff, students, and visitors for academic and special research purposes and goals;
- improve the proximity of the facility to North Campus, ideally accessible by LRT, for better access by students, staff, and researchers; and
- provide appropriate quantity, type, and function space for processing, storing, and digitizing materials in the collection.

The parcel of land allocated to RCRF was derived from the Sector 12 Plan. For the purpose of defining development boundary, the project site of 184 m x 81 m has been established, offering 14,900 m² (3.68 acre) in area. The Site #3 of Sector 12, District 2 has been selected for reasons of: access, alignment with planned utility right of way, and manageable impact to current research and operations for the Faculty of Agricultural, Life and Environmental Sciences. The majority of parcel's buildable area is delineated by two rows of trees, acting as wind breakers. The site topography is uniform with a minimal northerly slope. The project aims to minimize development impact, respecting its current siting context and the land value, achieving a low floor area ratio (FAR) and site coverage, and maintaining significant open spaces on site.

Includes reference to planning (development) guidelines and design guidelines (architectural design principles).

Issues

The challenging aspects of the RCRF project are:

- meeting program requirements while aligning with campus planning guidelines;
- confirmation of 9.1 m (30') high-density storage capacity to accommodate the combined BARD collections, University Archives, and maps – achieved through the engagement of an expert racking designer and supplier (Space Saver) early in the validation phase to verify, optimize and develop project-specific overall reduced storage area, while meeting the 20 year capacity growth objective;
- balancing LRDP planning principles with shorter and longer term operational needs of RCRF – achieved through extensive analysis of siting options and design that is engaging while improving access for researchers, students, staff, and service from the east. Ample opportunity for future growth in the west part of the site for potential academic and/or collection expansion was addressed through realizing reduced site coverage; and
- initially undefined size of the total building area (BGSM) – addressed through a critical review and prioritizing of all functional areas, increased use of shared and open spaces resulting in a reduced general circulation and economized size of all reviewed operational components. Space program update, rationalizing and validation process included participation of Library Services.

Development of Site #3 of Sector 12, District 2 brings an Academic/Research facility onto South Campus. The purpose designed RCRF provides safe, environmentally controlled high-density storage to establish a modern records depository with a holding capacity accommodating up to 20 years growth projections. The design is conceived to provide for expansion opportunities to accommodate future academic and/or storage needs. Through a mindful approach to the new facility site placement and site coverage, both the operational shorter-term library and collections considerations and longer-term campus growth goals are balanced.

* This is included in the 5.1M total.

RCRF provides for a venue for advanced collections including digitization, archive access and research. It includes a dedicated reading room for pre-arranged study that is critical for academic success; augmented by secure, purpose designed library and archives staff services, sorting, and processing areas.

The opportunity for re-branding of the University's Research Collections and Resource endeavours through this facility.

Recommendation

THAT the GFC Facilities Development Committee (FDC) approve the proposed RCRF – Schematic Design Report.



UNIVERSITY OF ALBERTA RESEARCH & COLLECTIONS RESOURCE FACILITY

SCHEMATIC DESIGN REPORT

ISSUED NOVEMBER 9, 2015



List of Illustrations

0.0 Cover

View of Proposed Facility

Executive Summary

RCRF East Elevation

1.0 Introduction

2.0 Architectural

Site Plan - University of Alberta South Campus
 Activity Flow Chart
 Design Exercise – Work Flow Mapping
 Fit Study – Filing Cabinets
 Space Reconciliation Table
 UA South Campus Land Use Plan
 Parcel D-2 #3 Site Dimensions
 Wind Rose Data, Edmonton, AB
 Precipitation Table
 Average Temperatures Table
 Site Specific Development Guidelines Table
 Site Plan
 Level 1 Floor Plan
 Mechanical Penthouse Plan
 Mechanical Mezzanine Plan
 Building Elevations
 Building Sections
 South-East Elevation
 South Elevation
 East Elevation
 North Elevation
 East Elevation
 North-East View
 West Elevation
 South-West View
 Night Rendering
 View of Reading Room Looking South-East
 Partial Plan – Spatial Separation & Exposure Protection
 Table 3.2.3.1.E – Unprotected Opening Limits for a Building of Fire Compartment that is Sprinklered Throughout
 Table 3.2.3.7 – Minimum Construction Requirements for Exposing Building Faces

3.0 Structural

Foundation Plan
 Roof Framing Plan (Elevation 104.800)
 Roof Framing Plan (Elevation 106.200)
 Roof Framing Plan
 Mechanical Mezzanine Framing Plan
 Mechanical Mezzanine Framing Plan (Elevation 109.200)
 Section

4.0 Mechanical

Design Requirements Table
 Site Plan
 Lower and Upper Mechanical Room
 Air Handling Equipment Schematics
 Mechanical Piping Schematics
 Sprinkler Tree Fire Pump Room

5.0 Electrical

Electrical Site Plan
 Main Electrical Room Layout
 Main Communication Room Layout
 Power Distribution Single Line Diagram
 Communication System Schematic
 Storage Area Lighting Layout and Calculations

6.0 Landscape

Concept Design Sketches
 Concept Design Plan
 Landscape Design Plan
 Landscape Design Detail Plan

7.0 Civil

Site Plan
 North Property Line Cross Section
 Topographical Survey (partial view) – by WSP

Table of Contents			
Executive Summary	4		
1.0 Introduction	7		
Project Background			
Purpose and Scope			
Methodology			
Participants			
Sign-Off			
2.0 Architectural Design	11		
Program Analysis			
Space Reconciliation			
Existing Conditions & Site			
Summary of Options			
Design Concept			
Sustainable Design			
Fire and Life Safety			
3.0 Structural Design	37		
Codes and CSA Standards			
Design Loads and Design Considerations			
Foundation System			
Superstructure Framing			
4.0 Mechanical Design	45		
Design Criteria			
Site Services			
Plumbing			
Heating System			
Cooling System			
Ventilation System Description			
Fire Protection			
Control System			
Sustainable Design Strategies			
5.0 Electrical Design		55	
Introduction			
Sustainable Design Considerations			
Power Distribution			
Lighting			
Fire Alarm System			
Low Tension Systems			
Communication Infrastructure			
Commissioning and Testing			
6.0 Landscape Design		65	
7.0 Civil Design		71	
Existing Site			
Site Servicing			
Site Grading			
Future Considerations			
8.0 Appendices		75	
Appendix A			Project Schedule
Appendix B			Cost Plan (excluded)

Opened in 1994, the Book and Record Depository (BARD) is a high density library storage facility that houses less frequently accessed library materials, research collections and the University of Alberta Archives. The Facility holds mostly books and journal volumes, but also microfilm, maps, audio discs, manuscripts, archives, and other formats normally collected by research libraries. Staff at BARD receive, process and create machine-readable records for newly deposited materials and provide circulation and document delivery services. Together these constitute one of Canada's most significant academic and cultural resources. BARD has been located in the leased and adapted commercial facility located off of the UA campus. The projected growth of BARD cannot be appropriately accommodated at that location, when the lease expires.

In July 2015, the Design Build (DB) Team, led by Stuart Olson, was retained to proceed to Phase 1 of this project, namely the design phases. The report contained herein formulates one of two major submissions that the DB project team is to deliver during Phase 1.

Phase 1, defined as the Validation Stage/Schematic Design in the original Request for Proposal documents, is to "translate the project requirements into space parameters, to explore preliminary design options and analyze them against priorities and program objectives". The following is a summary of the project highlights and the Design Build Team's work through this phase.

1. Purpose of the Project

Replace the existing Book and Record Depository (BARD) with a new, purpose-built Research & Collections Resource Facility (RCRF) to be built on South Campus. The BARD collections, and co-located with it the University Archives, will be relocated and augmented by the volumes transferred off the North Campus, to ease campus space pressure and accommodate new technological functions of Library Services.

The new RCRF facility will:

- Provide proper environment in which to store materials protecting the irreplaceable collection and the University Archives;
- Lower the risk of stored materials damage, decreasing the liability exposure;
- Provide the required capacity and afford expansion space and future growth (20 years) for related or complimentary use occupancies;
- Offer improved access from the UA campuses, including use of public transportation;
- Align with Guiding Documents of: Dare to Discover, Academic Plan (Dare to Deliver) and Long Range Development Plan (updated June 2013).

2. Objectives of the Project

The Research Collection and Resource Facility (RCRF) objectives are:

- Accommodate up to 5.1M volumes capacity to grow from the current 3.1M BARD print volumes projected over the next 20 years and the backlog of unprocessed materials to the collection;
- Accommodate up to 1.0M items relocated from North Campus to free up valuable space for academic requirements;
- Accommodate the University Archives, currently co-located with BARD;
- Provide an appropriate, functional and welcoming space for staff, students and visitors for academic and special research purposes and goals;
- Improve the proximity of the facility to North Campus, ideally accessible by LRT, for better access by students, staff and researchers;
- Provide appropriate quantity, type and function space for processing, storing and digitizing materials in the collection;
- Meet budgetary of \$21.0M construction cost, including high density racking;
- Meet schedule requirements of mid-2017 facility takeover.

3. Deliverables

The Validation (Phase 1 – Schematic Design) deliverables are summarized in this report and include:

- The validation of the Functional Program (March 26, 2015), that was previously approved by FDC;
- Following an exploration of various design concept options, articulate the strongest and most feasible design concept, as developed by the DB team;
- A site analysis for the chosen Parcel D2-#3 on South Campus which includes a regulatory review, sector analysis, fire and life safety strategy, site services strategy, preliminary landscape solution, major utilities tie-in, site grading & drainage, etc.;
- Summaries and sketches of the conceptual system descriptions for structural, mechanical, electrical, civil and landscape;
- A detailed cost plan and project schedule.



RCRF EAST ELEVATION

4. Site

The parcel of land allocated to RCRF was derived from the Sector 12 Plan. For the purpose of defining development boundary, the project site of 184 m x 81 m has been established, offering 14,900 m² (3.68 acre) in area. The Site #3 of Sector 12, District 2 has been selected for reasons of: access, alignment with planned utility Right of Way and manageable impact to current research and operations for the Faculty of Agricultural, Life and Environmental Sciences. The majority of parcel's buildable area is delineated by two rows of trees, acting as wind breakers. The site topography is uniform with a minimal northerly slope. The project aims to minimize development impact, respecting its current siting context and the land value, achieving a low Floor Area Ratio (FAR) and site coverage, and maintaining significant open spaces on site.

With several site options considered, the main entrance and operational/services access location was placed facing east, and close to 115A Street, taking advantage of the existing vehicular access, and multi-use pedestrian/bicycle pathway connecting with the LRT station nearby. With the single storey "front of house" pavilion located along 115A Street edge, the high density storage massing shifts back towards the site centre, following the planning principle of graduating the growth density towards the South Campus centre. The northeast corner of RCRF provides for services and delivery dock access, while the southeast part is directed towards pedestrian access and public realm connectivity to follow future LRDP development of pedestrian and bicycle routes campus network. The west and possibly the south portion of the site is reserved for future expansion of the current facility or additional program development.

The RCRF will have limited staff parking in immediate proximity of the facility, utilizing the pool of staff parking areas provided on the South Campus. Limited numbers of short-term parking stalls, delivery/pickup dock and service and maintenance vehicles access is provided to the facility.

The current site constraints include:

- Below grade geotechnical conditions of highly plastic soil and a relatively high water table;
- Mature elm trees windbreaker within south part of the site;

- The proximity of Storage Garage to the north imposing limiting distance considerations;
- No underground storm water infrastructure.

5. Challenges

The challenging aspects of the RCRF project are:

- Meeting program requirements while aligning with campus planning guidelines.
- Confirmation of 9.1m (30') high density storage capacity to accommodate the combined BARD Collections, University Archives and Maps – achieved through the engagement of an expert racking designer and supplier (Space Saver) early in the validation phase to verify, optimize and develop project-specific overall reduced storage area, while meeting the 20 year capacity growth objective.
- Balancing LRDP Planning Principles with shorter and longer term operational needs of RCRF – achieved through extensive analysis of siting options and design that engages the public realm to improve researchers, students, staff and service access from the east. Ample opportunity for future growth in the west part of the site for potential academic and/or collection expansion was addressed through realizing reduced site coverage.
- Construction budget – projected higher cost, in big part due to geotechnical conditions confirmed to exist on site, and a higher cost of racking system priced in US Dollars, resulting from a less favourable CAD to USD exchange rate. This challenge has been addressed by a budget increase within the overall approved project funding amount.
- Gaining South Campus Community support – through U of A communication strategies and Open House community engagement, including presentations and gathering of opinions and input.
- Initially undefined size of the total building area (BGSM) – addressed through a critical review and prioritizing of all functional areas, increased use of shared and open spaces resulting in a reduced general circulation and economized size of all reviewed operational components. Space program update, rationalizing and validation process included participation of Library Services.

6. Opportunities

Development of Site #3 of Sector 12, District 2 brings about the first Academic/Research facility onto South Campus. The purpose designed Research Collections and Resource Facility (RCRF) provides safe, environmentally controlled high density storage to establish a modern records depository with a holding capacity accommodating up to 20 years growth projections. The design is conceived to provide for expansion opportunities to accommodate future academic and/or storage needs. Through a mindful approach to the new facility site placement and site coverage, both the operational shorter-term library and collections considerations and longer-term campus growth goals are balanced.

RCRF provides for a venue for advanced collections and archive access and research. It includes a dedicated reading room for pre-arranged study that is critical for academic success, augmented by secure, purpose designed library and archives staff services, sorting and processing areas.

A rebranding of the University's Research Collections and Resource endeavors through this facility.

7. Design Principles

While balancing the needs of the facility program with campus-wide land use and design guidelines, a number of criteria and design principles were identified by the team and used as a means to develop the following design solution. This includes the following:

- Provide authenticity and derive typology;
- Provide an appropriate functional distribution of the major operations, as programmed;
- Provide a solution that is contextual within the existing fabric of South Campus;
- Provide maximum expansion potential;
- Provide appropriate massing and human scale through articulation;
- Provide a balance between the expression of the building from outside and an the experience of the occupant inside;
- Provide a significant point of arrival to the facility.

8. Concept Design

As presented at the first Community Open House, held on July 27, 2015, the approach to concept was the following:

Building design shall be contextual – compatible in form and scale to complement the adjacent buildings. In addition, building massing shall be a composition of forms and elements shaped by functionalities and arranged so as to facilitate ease of operations, readability, wayfinding and interpretation while creating interest, human scale, meaning and delight.

Buildings are to contribute to the campus-scape of South Campus while enhancing the adjacent public realm. They should be engaging and transparent to edges, pedestrian plazas, pathways and circulation corridors. Project siting to retain and enhance existing campus fabric, maximize future development expansion space and flexibility.

RCRF should complement and enrich buildings on South Campus.

Connectivity should be cohesive, barrier-free, engage existing and anticipate future planning.

Project is to incorporate sustainable design principles and be secure, durable and efficient construction. Building orientation to enhance natural daylighting and view corridors as well as reduce wind and energy impacts.

9. Process

The Modified Design Build process afforded on-going engagement of the University personnel, accelerated key project decision and brought forward known issues to be avoided in the design. It encouraged generation, review and selection of early design options, progressively refining those, and created opportunity for effective dissemination of decisions communicated promptly as a timely input during the validation phase.

The Library Services offered a dedicated on-campus space for weekly project team meetings, where focused presentations of a developing design, schedule and budgetary discussions were encouraged and allowed participation of all key stakeholders.

Additional series of complementary working meetings with the Library Services also occurred in the same “big room” space to advance understanding, updates and necessary modifications to the functional program. In order to meet the timeline the University provided direct access to operations and project management personnel imbedded directly into the project during the validation phase. This process supported transfer of information on site constraints, queries on South Campus LRDP, clarifications to concurrent planning of campus utilities infrastructure that could affect the project, potential impact to the neighbourhood and all other project inputs brought into decision process by all members of the integrated project delivery approach.

10. Design Solution

The design solution that is fully articulated throughout this report has been developed by an integrated team. The proposed solution follows the merits of the Functional Program but also improves upon found space and work flow efficiencies. Considerations of daylight and visibility have also been developed. By and large the LRDP guidelines are adhered to, acknowledging that the development of the Sector Plan for Sector 12 is being developed concurrently. Likewise, community input has been taken into account. There are some objectives, which were outlined at the Community Open House, that have not been achieved, such as:

- The preferred siting with the ‘front of house’ to the west was not practical, considering the existing infrastructure and the restrictions for the DB team to construct anything south of the tree line.
- Locating the facility between the existing tree lines challenges the proposed setbacks.
- The overall height of the building is closer to 40’ versus the original 60’.
- A two storey ‘front of house’ solution was not achievable from a work flow perspective. Operationally the work flow is better with a single storey layout. Alternatively, massing is used as a means to mitigate and reconcile two different building heights.
- Future expansion capability.

11. Program Reconciliation

The original Functional Program was prepared by the University of Alberta in March 2015. It encompassed a brief of the project objectives and concluded with a space summary. At that time, it was anticipated that a facility of 4,840 component gross square meters (CGSM) was required to meet the 20 year growth goals of the Research & Collections Resource Facility. This figure did not include a factor for grossing the programmed space up to a complete building gross square meters (BGSM).

Through a process of engaging the key stakeholder group, the Functional Program has been validated and updated. The projected space requirements have been discussed, reviewed and verified by the Library Services and the Design Build Team. While in general operationally and functionally aligned with the FDC-approved Functional Program of March 2015, it has been determined that the facility, as presented in the following report, meets the project objectives and can accommodate the functional requirements of the Research & Collections Resource Facility within a reduced size of approximately 4,040 BGSM. Included in this total is 2,510 CGSM dedicated to the high density storage of 9.1m (30’) racking height and housing BARD Collections, University Archives and Maps. A separate, dedicated and also environment-controlled programmed space of 130 CGSM accommodates Microfiche/Film stacked storage. The concept of an enclosed drive-in delivery dock has been modified and replaced by a protected exterior enclosure. The resulting building grossing factor is at this phase 1.16 (or 16%).

12. Facility and Site Operations & Maintenance

The integration of all project stakeholders in the modified Design Build process, and the Library Services in particular, provided for valuable input on operational and maintenance issues to be considered and addressed to support early planning decisions. A more detailed functional layouts, including placement of fittings, furnishing and major equipment (FFE) will be further advanced in Design Development.

Facility Operations & Maintenance considerations have been incorporated into Schematic Design during project validation phase through direct engagement and involvement of the University Technical team. Information from concurrent of South Campus utilities planning informed RCRF design team of directions and services made available in support of the project.

A the Schematic Design and validation phase several value-added visits to BARD (current operation) and a similar high density storage recently brought into operation at the University of Calgary, provided tangible operational and maintenance issues that shaped the design from its earliest phase. The functional program parameters were translated early into several space layout options that confirmed operational necessity of implementing a single storey RCRF building with the main mechanical services located in a penthouse above. Implementation of functional zoning responds to the operational requirements for scheduled visits by researchers and students, with consideration given to balancing the on-site collections/archives access with the necessity of protecting and preserving valuable on-site resources. The design aims at creating both a visiting and working experience that encourages and supports academic pursuits and affirms importance of the facility to the University of Alberta. The design provides for environmentally purposed storage areas that offer lowered temperature and lower humidity to effectively protect the collections, archives, maps, microfiche, film and other repository items.

A relatively small contingent of Library Services personnel is provided with originally programmed and some added spaces to support the RCRF functions and to create a pleasant and welcoming work environment that offers space utilization flexibility, social space and access to daylight, where possible. A purposefully compact layout reduces travel distance and movement of book-carrying trucks, including a large NEOS sorting area. The main visitor entrance becomes a destination point and engages functionally and visually by both the pedestrian passer-by and public travelling the adjacent LRT line. The service access for deliveries and pick up functions and building services infrastructure is located separate from the visitor entrance.

Operational, maintenance and servicing access points were discussed and reviewed with the University technical teams and developed with advancement for all building systems described at the schematic design phase.

13. Budget and Schedule Alignment & Reconciliation

At the completion of the Schematic Design phase, the concept design, as described within this report, is within the project budget, as established by the UA project Management Team. In addition, the project can be constructed within the established project schedule.

1.0 INTRODUCTION

Project Background

The Book and Record Depository (BARD) is a library storage facility located off of the UA campus. Opened in 1994, BARD is a high density storage facility that houses less frequently accessed library materials, research collections and the University Archives. The Facility holds mostly books and journal volumes, but also microfilm, maps, audio discs, manuscripts, archives, and other formats normally collected by research libraries. Staff at BARD receive, process and create machine-readable records for newly deposited materials, and provide circulation and document delivery services. Together these constitute one of Canada's most significant academic and cultural resources. Over the past several years, the University has been investigating options to relocate the collection from BARD. A new facility, the Research & Collections Resource Facility will be built on South Campus.

In July 2015, the Design Build Team, led by Stuart Olson, was retained to proceed to Phase 1 of this project, namely the design phases. The report contained herein formulates one of two major submissions that the team will submit during Phase 1.

The objective of this first design phase, defined as the Validation Stage in the original Request for Proposal documents is to "translate the project requirements into space parameters, to explore preliminary design options and analyze them against priorities and program objectives". The following is a summary of the Design Build Team's work through this phase.

Purpose and Scope

The purpose of the Schematic Design Report is to:

- provide the user group with an understanding of the scope of the project;
- provide validation of the Functional Program;
- provide enough information in order that a cost estimate can be generated;
- provide the design team with direction to move directly into the preparation of Design Development and Contract Document production.

Methodology

During this Phase, the Design Build Team met weekly in an integrated 'Big Room' format. During meetings the team shared ideas, presented concepts, debated options and generally collaborated on the development of the concept design. Additionally, the key stakeholder group met weekly to discuss and develop operational concepts for the new facility. Design team members were invited to join this series of meetings in order to advance the Functional Program validation process. Other small working group meetings were held throughout the design phase. Meeting minutes were generated for all meetings.



WORKSHOP DESIGN SESSION, SEPTEMBER 17, 2015

Participants

This document was prepared with the help and participation of many individuals. The members are listed below for reference:

University of Alberta:

- Gerald Beasley, Vice-Provost & Chief Librarian
- Sandra Shores, Associate University Librarian
- Pat Jansen, Associate Vice-President, Planning & Project Delivery, Facilities and Operations
- Todd Werre, Director, Project Management Office
- Blake McMillan, Project Manager, Project Management Office
- Keith Hollands, Associate Director, Design & Technical Services
- Ben Louie, University Architect
- Kelly Hopkin, Senior Campus Planner, Architecture
- Laurel Roblin, Utility Service Manager – Mechanical Utilities
- David Roh, Utility Service Manager – Electrical Utilities

Graeme Alston, Acumen Cost Consulting (independent cost consultant for UA)

Design Build Team:

- Ryan Christensen, Stuart Olson Construction Ltd.
- Sean Kangas, Stuart Olson Construction Ltd.
- Joe Leonard, Stuart Olson Construction Ltd.
- Russyl Workman, Stuart Olson Construction Ltd.
- Atef Matta, Stuart Olson Construction Ltd.
- Jason Franchuk, Stuart Olson Construction Ltd.
- Janet Koshuta, HFKS Architects Inc.
- Chris Filipowicz, HFKS Architects Inc.
- Sergio Poles, HFKS Architects Inc.
- Robert Timms, HFKS Architects Inc.
- Diana Chernenko, Chernenko Engineering Ltd.
- Salvador Grandon, Chernenko Engineering Ltd.
- Migo Kelada, KFR Engineering Ltd.
- Mark Lafreniere, KFR Engineering Ltd.
- Derek Ciezki, SMP Engineering Ltd.
- Henry Chu, SMP Engineering Ltd.
- Ted Muller, EDA Collaborative Inc.
- Mike Shankaruk, Arrow Engineering Inc.
- Maz Kitabwalla, Arrow Engineering Inc.
- Stephani Carter, EcoAmmo Sustainable Consulting
- Madeleine Drake, EcoAmmo Sustainable Consulting
- Rej Boutin, Priority Mechanical Ltd.
- DJ Coppens, Territorial Electric Ltd.
- Lee Broadbent, Territorial Electric Ltd.

Sign-Off Sheet

In accordance with the Agreement, we are submitting for review and approval the Schematic Design Report. We respectfully request that copies of this report be circulate to the appropriate departments and individuals who are the key stakeholders in this project. The following report is intended to convey the project scope at this stage.

Approval of this report provides the Design Build team with the authorization to proceed to the next step of the planning process, namely Design Development. Comments can be made and noted on this report and the documents will be revised or amended accordingly, with the approval of the Client.

The undersigned have reviewed the Schematic Design Report contained herein and accept its contents as representing the requirements of the design phases and updated respectively during the planning process.

Pat Jansen
Associate Vice-President, Planning &
Project Delivery, Facilities and Operations

SIGNATURE

DATE

Ben Louie
University Architect

SIGNATURE

DATE

Kelly Hopkin
Senior Campus Planner, Architecture

SIGNATURE

DATE

Gerald Beasley
Vice-Provost & Chief Librarian

SIGNATURE

DATE

Keith Hollands
Associate Director, Design
& Technical Services

SIGNATURE

DATE

Todd Werre
Director, Project Management Office

SIGNATURE

DATE

PAGE INTENTIONALLY LEFT BLANK

2.0 ARCHITECTURAL DESIGN

Program Analysis

The Research and Collections Resource Facility (RCRF) Functional Program document dated March 26, 2015, has been provided to the project team as the basis for further planning and design. During the validation phase a number of space programming parameters have been further analyzed and discussed with the User Group and the entire project team. The resulting modifications and adjustments aimed at optimizing and balancing the capital funding with the operational objectives and RCRF goals, which were stated in the Program as to:

- Provide an appropriate, functional and welcoming space for staff, students and visitors for academic and special research purposes;
- Be located in a more suitable, low-risk location, free from a high-risk dangerous goods railway line, decreasing the liability exposure and risk profile, protecting the irreplaceable collection and the University Archives;
- Improve the proximity of the facility to North Campus, ideally accessible by LRT, for better access by students, staff and researchers;
- Accommodate growth and the backlog of unprocessed materials to the collection;
- Accommodate up to one million items relocated from North Campus to free up valuable space for academic requirements; and
- Provide appropriate quantity, type and function of space for processing, storing, and digitizing materials in the collection.

Program Overview

A high-density storage facility is considered a closed-stack storage model whereby it holds less-accessed research and reference materials not accessed by the public. Upon request, these items are delivered to other university library locations by an in-house delivery service. The University will maintain more frequently accessed materials in existing, but downsized open stack shelving in existing Library facilities across the University of Alberta (U of A) campuses. University of Alberta Libraries (UAL) is an active member of NEOS (from the historical name: Networking Edmonton's Online Systems), which is a 17-Library consortium in central and Northern Alberta who share resources, technology and collections across the region.

The Functional Program is largely based on the high-density storage requirements of 3,437 component gross square meters, validated and rationalized to a smaller area. This number is based on a volumetric capacity of 30 foot high shelving in an efficiently laid out warehouse of open rack shelving with a manned lift (picker) for retrieving trays from the shelves. The high-density storage facility in RCRF would need to accommodate the existing 3.1 million items from BARD, a relocation of one million items from North Campus, and a growth projection of 50,000 items per year for 20 years, for a total of 5.1 million items projected capacity over 20 years. The University Archives is currently measured at 7.3 km of shelving space and is anticipated to grow 100m/year for 20 years, for a total growth of 2.0 km, reaching a total Archives capacity of 9.3 km. The entire inventory requires a temperature and humidity controlled environment, to be accommodated within a dedicated area of the high-density storage.

The warehouse support space, to be adjacent to the warehouse space and to accommodate: pallet storage, sorting and processing space for incoming inventory and space to maneuver and park forklifts (order pickers), including space for their batteries and charging stations. The indoor vehicle loading/unloading space was subsequently removed from the program requirements and replaced with a sheltered and protected exterior enclosure.

Space is also required to accommodate additional items for intermittent retrieval including: microfiche, microfilm and map cabinets. These items would be relocated from North Campus and all require reinforced flooring due to their weight. Film will also need to be accommodated in a temperature controlled cold room.

Library Services and Information has identified a requirement for a second Digitization Area as the collection is actively being digitally archived, with one print copy kept in the collection. There is an existing digitization space on North Campus (Level 2, Cameron Library) but having a second one provides the ability to expedite the long process of digitizing the collection. Related to this, the need for a Media Migration Room to house equipment to transfer different types of film to digital records, will be accommodated within the space allocation for the Digitization Area.

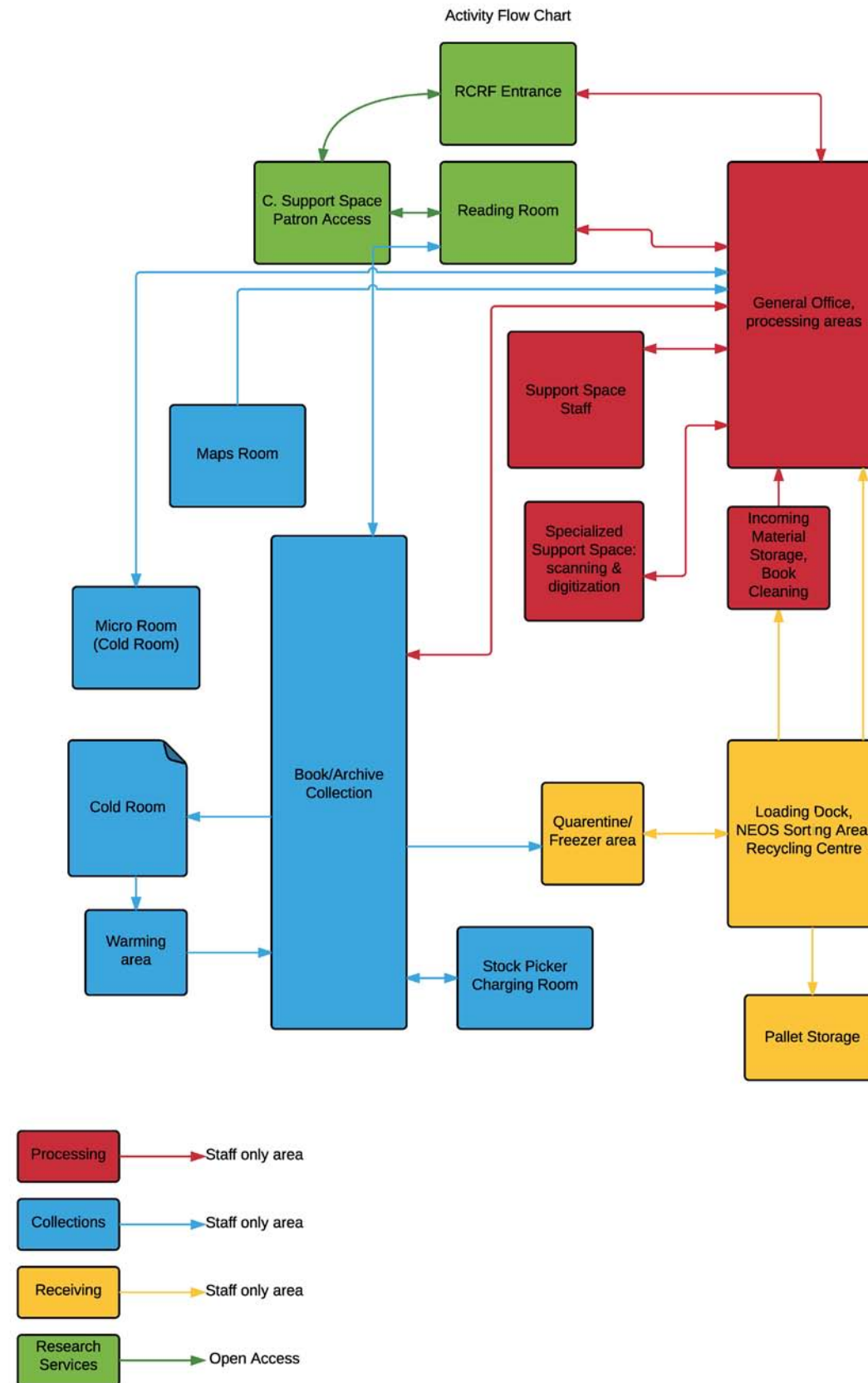

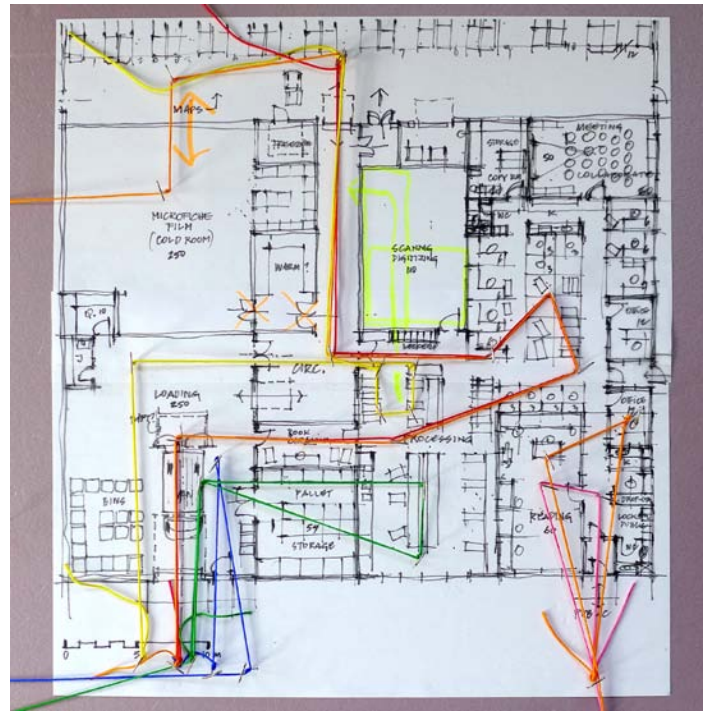

Design Exercise - Work Flow Mapping

Space is also required for staff, students and public use. The staff component includes office space for RCRF staff and Archives staff (most of it in an open work space concept), additional book processing space, a collaboration/meeting space, staff lockers, kitchenette, copy room and office supplies storage.

Public support spaces are intended for the use of researchers and visitors wanting to access items from the University Archives, which must remain within the facility and are not able to be borrowed. Most researchers visit for full day time periods, so an Archives Reading Room is required, as well as a small waiting area, lockers for personal items (no backpacks allowed for collection security) and a small kitchenette for heating lunch, would be required.

Program Implementation Methodology

Program space requirements have been based on a variety of metrics. The individual office space components follow the UA space standards and guidelines that stipulate combination of enclosed and open space work areas. Warehouse storage requirements were programmatically based on a calculation of typical high-density book storage dimensions placed in to 'trays' which are placed on shelves, the capacity of shelves, the height of shelves and an approximate layout of shelving racks in an open warehouse. These factors resulted in an overall volumetric capacity, factored for a targeted volume and then translated to an approximate overall area requirement. Those parameters were subsequently further advanced by the project team that engaged a specialist racking sub-consultant to review and validate the initial programmed space allocation targets. More detailed collection racking system layouts were developed and assessed based on specific to the present and the projected RCRF storage space requirements, thus updating and further defining what and how a variety of items will be accommodated in the main high density warehouse space.

Other areas, such as the Digitization Area, Map Room, Microfiche and Microfilm areas are based on existing room areas in Cameron, Rutherford North and J.W. Scott Libraries. The remaining requirements such as loading dock, cold room and sorting spaces are based on existing space at the existing BARD and the now UA-owned Federal Archives Building.

All the diverse program components were discussed and reviewed with the User Group, who provided an updated description of the RCRF operation, allowing the design team to develop and present several planning options during interactive program validation sessions. Those in turn offered opportunities for combining some functional components, defining their process flows based on the required affinities and staffing model.

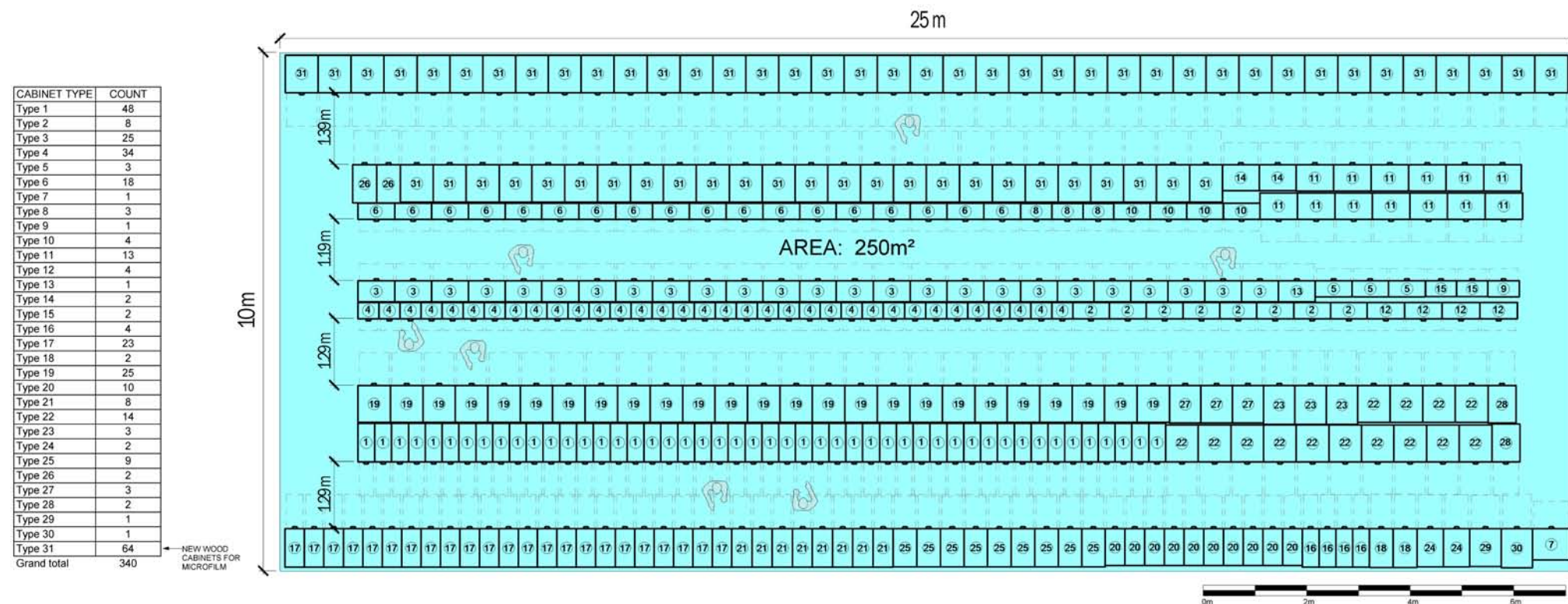

PRELIMINARY LAYOUT OF MICROFICHE / FILM COLD ROOM BEFORE REDUCTION OF AREA TO INTRODUCE STACKED STORAGE

Space Reconciliation

The Functional Program space requirements presented in the March 2015 document and its implementation at Schematic Design are provided in the following analysis spreadsheets along with the corresponding commentaries.

Reference notes to the Functional Program space reconciliation:

- Includes book processing space of an additional 3.0 NSM for each Full Time (FT) personnel's work area and allocated in the Program under "Support Space".
- Component Grossing Factor of 1.35 (35%) applied as per Program.
- Listed with BARD and Archives staff enlarged work areas.
- Collaboration/Meeting/Lunch Room increased in size to 50.0 NSM to accommodate up to 20 people, aligning with a smaller classroom capacity. Programmed space increase achieved through reallocation of space initially assigned to "Hold & Self Check", as directed by the User Group.
- Lowered Component Grossing Factor of 1.15 applied (15%) responding to the type of functions included.
- Programmed space allocation reduced by the User Group through validation process and rationalizing initially projected area.
- Collections Reading Room space combined with Archives Reading Room as per User Group's updated functional requirements and to facilitate invigilation, for a total of 60.0 NSM.
- "Hold & Self Check" area deleted from the operational requirements by the User Group. Programmed space allocation added to Collaboration/Meeting/Lunch Room, increasing its size.
- Small negative space allocation variance with the initial Program results from conversion of CGSM listed as NSM, while retaining a required functionality. Lower Component Grossing Factor of 1.15 (15%) is applied.
- Digitization area stated in the Program has been operationally rationalized by the User Group and reduced with the project team from 148.0 CGSM to 67.0 CGSM. This space allocation was in turn redistributed between Collection Processing (BARD Staff area increased by 42.0 CGSM) and Archive Processing (Archives Staff area increased by 25 CGSM).
- The Programmed area allocation has been reduced by the User Group to 150 CGSM to be accommodated within the main Collections Racking space, utilizing the existing or new storage units.
- Microfiche/Film Storage to be accommodated within a smaller stacked storage footprint and combined with the Cold Room to assure necessary lower temperature/humidity control environment, which is different from the high density storage warehouse. The area requires a small "warming vestibule" to condition stored items that transition between environments differing in temperature and humidity. Reduced CGSM area assumes implementation of two or three levels stacked storage cabinets to economize project space utilization within the higher ceiling. No mechanized lifting or access equipment is anticipated to be employed in this area that relies on warehouse-type access step ladders with handrails. This area will require an increased structural floor loading capacity.

**Research and Collections Resource Facility (RCRF)
Space Programme Requirements**

Schematic Design Space Programme Update

* January 15, 2015; Incorporates feedback from Gerald Beasley and Kathryn Ar buckle from December 8, 2014 and email exchange with Kathryn in January 2015 as a follow up.

Division / Space Type	Occupants OR Based On	Location of Existing Space			Projected Need (2035)			Schematic Design Programme Implementation						
		Room No.	No. Occ.	Area (Nasm)	No. Occ.	Unit Allow.	Area (Nasm)	No. Occ.	Unit Allow.	Area (Nasm)	Component Grossing Factor	CGSM	CGSM Variance	Notes
A. General Office														
BARD STAFF														
1 Qty 1, Manager	Qty 1, FT	BARD	-	-	1	12.0	12.0	1	15.0	15.0				Ref. 1
2 Qty 5, Staff, FT Permanent	Qty 5, FT	BARD	-	-	5	6.0	30.0	5	9.0	45.0				
3 Qty 3, Staff, PT, Casual	Qty 3, PT	BARD	-	-	3	3.0	9.0	3	3.0	9.0				
4 Qty 3, FUTURE, PT, Casual	Qty 3, PT Future	BARD	-	-	3	3.0	9.0	3	3.0	9.0				
NASM Subtotal Staff (Office)								78.0			1.35	105.3		Ref. 2
ARCHIVES STAFF														
5 University Records Archivist	FT	BARD	-	-	1	12.0	12.0	1	15.0	15.0				Ref. 1
6 Archivist Librarian	FT, Future	BARD	-	-	1	9.0	9.0	1	12.0	12.0				
7 Assistant	FT	BARD	-	-	1	6.0	6.0	1	9.0	9.0				
8 Volunteer, Casual	Qty Varies, PT	BARD	-	-	1	3.0	3.0	1	3.0	3.0				
NASM Subtotal Staff (Office)								39.0			1.35	52.7		Ref. 2
B. Support Space (Office)														
1 Extra Book processing/book cart space (added to FT Wkstns)	Qty 9 FT @ 3.0sqm	-	-	-	9	3.0	27.0	0	0.0	0.0				Ref. 3
2 Kitchenette (adjacent or part of Collaboration/Mtg. Rm)	new	-	-	-	1	8.0	8.0	1	8.0	8.0				
3 Collaboration/Meeting/Lunch Area	new	-	-	-	12	2.5	30.0	20	2.5	50.0				Ref. 4
4 Locker Area for staff	new	-	-	-	15	0.6	9.0	15	0.6	9.0				
5 General Storage/Supply/Copy Room	new	-	-	-	1	20.0	20.0	1	20.0	20.0				
NASM Subtotal Support Space (office)								94.0			1.15	100.1		Ref. 5
NASM Subtotal (Office)								184.0						
CGSM Subtotal (Office)								248.4						
C. Support Space (Public Accessed)														
1 Waiting Area c/w mail drop counter	new	-	-	-	1	12.0	12.0	1	8.0	8.0				
2 Nutrition Nook (for public) c/w microwave, sink, etc.	new	-	-	-	1	8.0	8.0	1	4.0	4.0				Ref. 6
3 Lockers for Public (backpacks, purses not allowed in Archives)	new	-	-	-	15	0.6	9.0	15	0.3	4.5				Ref. 6
4 Reading Room for Archives, locked after hours, based on 5.0sqm/person for large layout tables (5'x3.5') and boxes, etc.	For 4 people	-	-	-	4	5.0	20.0	4	5.0	20.0				Ref. 7
5 Reading Room for Public, open after hours	For 8 people	-	-	-	8	5.0	40.0	8	5.0	40.0				Ref. 8
6 Hold and Self-Check Area	new	-	-	-	1	16.0	16.0	0	0.0	0.0				Ref. 5
CGSM Subtotal (Public Accessed)								105.0			1.15	88.0		Ref. 9
NASM Subtotal								76.5						
CGSM Subtotal (Public Accessed)								88.0					-17.0	

Division / Space Type	Occupants OR Based On	Location of Existing Space			Projected Need (2035)			Schematic Design Programme Implementation						
		Room No.	No. Occ.	Area (Nasm)	No. Occ.	Unit Allow.	Area (Nasm)	No. Occ.	Unit Allow.	Area (Nasm)	Component Grossing Factor	CGSM	CGSM Variance	Notes
D. Support Space (Specialized Work/Storage and Loading Dock) Specialized Spaces														
1	Digitization Area (scanning, storage, prep), based on Cameron Level 2 Digital Archiving Studio of 123.6sqm plus 20% = 156.0	Level 2 Cameron +20%	-	-	-	1	148.3	148.3	1	67.0	67.0	67.0	-81.3	Ref.10
2	Map Room, based on 4.20A (108.6sqm) plus open area Level 4 Cameron (~54 sqm), possibility to stack map chests, floor loading).	Level 4 Cameron	-	-	-	1	162.6	162.6	0	0.0	0.0	0.0	-162.6	Ref. 11
3	Microfiche/film cabinet storage, based on JWScott Library 2K4.21 (207.6 sqm), possibility of higher cabinets, floor	John W. Scott Library 2K4.21	-	-	-	1	207.6	207.6	1	130.0	130.0	130.0	-77.6	Ref. 12
4	Media Migration Room, estimated size	new	-	-	-	1	20.0	20.0	0	0.0	0.0	0.0	-20.0	Ref. 13
5	Cold Room for Film, based on Fed. Archives of approx. 55 sqm, floor loading	Fed Archives/new	-	-	-	1	55.0	55.0	0	0.0	0.0	0.0	-55.0	Ref. 14
6	Walk-in Freezer	new							1	11.0	11.0	11.0	11.0	Ref. 15
Loading Dock Related														
7	Sorting Space, based on ~125 sqm at BARD +20%	~125 sqm at BARD +20%	-	-	-	1	150.0	150.0	1	150.0	150.0	150.0	0.0	
8	Pallet Storage (based on: 1 row of 6 bays, 3 shelves high), each Bay is 12'x8'=96sqft=8.9sqm; adjacent to sorting space so no additional circulation required.	8.9sqm/bay x 6 bays	-	-	-	1	53.6	53.6	1	53.6	53.6	53.6	0.0	
9	Loading Dock (approximation based on Fed Archives): To include space for 20 big recycle bins and indoor loading dock. Based on Fed Archives 1-117 (181.5sqm) + 1.118 indoor driveway (70.55 sqm) = 252.1 sqm.	Fed Archives	-	-	-	1	252.1	252.1	1	181.5	181.5	181.5	-70.6	Ref. 16
10	Book Quarantine Room	new							1	10.0	10.0	10.0	10.0	Ref. 17
11	Book Cleaning Room (with Vacuum Table)	new							1	15.0	15.0	15.0	15.0	Ref. 17
12	Pickers (2) Battery Charging Room	new							1	22.0	22.0	22.0	22.0	Ref. 17
							CGSM Subtotal (Staff Accessed)	1,049.2			CGSM Subtotal (Staff Accessed)	640.1	-409.1	Ref. 18
							CGSM Subtotal (Non-warehouse)	1,402.6			CGSM Subtotal (Non-warehouse)	986.1	-416.5	Ref. 18
E Book Collection, in 40' racking, incl. growth projections (See Note 4 below for details on collection size)							included in 3,437.4 below		included in 2,510.0 below					
F Archives (Based on 9.3km, converted to 183,136 Book volumes equivalent @ 40' high). Requires lower height and diff. environmental conditions and a separate 'picker' at ~\$50K plus). Based on 37,000 sq.ft = 3437.4 sqm							included in 3,437.4		included in 2,510.0 below					
							CGSM Subtotal (Warehouse)	3,437.4			CGSM Subtotal (Warehouse)	2,510.0	-927.4	Ref. 19
							CGSM GRAND TOTAL	4,840.0			CGSM GRAND TOTAL	3,496.1	-1,343.9	
Additional Spaces within Building Gross Square Metres (BGSM)														
A General Building Circulation 53.5														
B Public Entrance Vestibule 5.5														
C Air Lock to Collections Space 8.5														
D Janitorial Room 10.0														
E Public & Staff Washrooms 11.5														
F Mechanical Room (Fire Pump) 52.0														
G Electrical Room (Main Floor) 20.0														
H Access Stair to Mechanical Penthouse 12.5														
I TeleComm Room (within Penthouse) 13.0														
J Mechanical Penthouse 250.0														
BGSM additional spaces Subtotal 436.5														
<i>Effective Building Grossing Factor: 1.16</i>														
SCHEMATIC DESIGN GRAND TOTAL BGSM 4,040.0 <i>43,488 sqft</i>														

Notes:

- NASM: Net Assignable Square Metres.
- CGSM: Component Gross Square Metres (based on industry standard of 35% gross up factor for circulation within a suite).
- Does not include sqm for building gross up factors such as washrooms, stairs, weather vestibules, etc.
- Collection growth is based on the following. In Millions of Physical Items:
Existing BARD Collection 3.1M + Relocation from Ruth N. 0.5M + Relocation from other North Campus Libraries 0.5M + Cumulative growth of 1.0M over 20 yrs = 5.1M.
(Cumulative growth is based on 50K titles per year; Other Libraries includes Law, Medicine and Education).
- Existing Archives at 7.3 km; Archives growth is projected at 100m/year, so 2.0km over 20 years for a total of 9.3 KM.
- All program numbers to be confirmed prior to design start-up. Design layout to be as efficient and open as possible.

- The estimated Media Migration Room function to be accommodated within the reduced and re-distributed Digitization area, as operationally rationalized by the User Group during the Program validation.
- Cold Room eliminated by the User Group during Program validation to be combined with Microfiche/Film Storage function (also refer to note #12).
- The addition of a dedicated Walk-in Freezer, at 11.0 CGSM, as requested by the User Group to allow for freeze-dry recovery of wet books.
- Accommodation for an indoor drive-in loading dock has been deleted from in operational validation process reducing the area by approximately 71.0 CGSM. An enclosed and weather-protected exterior area will be provided to shelter from the elements, with further details to be developed.
- Unidentified in the Functional Program operational area added during validation phase to support operation of RCRF and related to the Loading Dock/Sorting functions.
- Reduction of project programmed area (CGSM) attributable to the enhanced User Group engagement and operational review, resulting in optimized space allocations within the Specialized Work/Storage and the Loading Dock. The initial programming assumptions were re-visited by the project team and vetted from the perspective of maximizing efficiencies, and increasing opportunities for co-sharing of spaces where operationally feasible, including facility maintenance. Opportunities to maximize open area spaces were explored and realized at the Schematic Design level, to be further advanced during Design Development through the identification and placement of furniture and equipment. The User Group reconfirmed operational benefits of maintaining all functional components at a single, at-grade level, except for the elevated Mechanical/Electrical service space located in the penthouse above. The validation process also benefited from the project capital parameters and its imposed limitations.
- The Program designation of 40' high racking has been reconfirmed as a 30' height requirement. Significant reduction in the initial high density storage warehouse was accomplished through consolidation of the Collections with Archives and Maps storage, validated through engagement of the specialized racking consultant, with more detailed shelving layout to follow. The proposed racking layout has been contained within approximately 2,500 CGSM floor space of a high density warehouse space. At the Schematic Design phase it consists as 12 double-sided aisles that accommodate 936 vertical sections (ladders) that could potentially accommodate up to 7,100,000 volumes based on a continuation of the current mix of collection size at BARD (i.e. tray and book sizes). This is to be confirmed by the User Group.
- Building Gross Area includes several elements referenced to, but sized in the Functional Program, which were defined at Schematic Design. Those areas typically include general circulation, washrooms, janitorial services, stairs and other building service areas (M&E) that support its function and operation. The Gross Building Area includes also the exterior walls, which may significantly add to the overall size of the facility.
- The effective Building Grossing Factor achieved at Schematic Design is 1.16 (16%) and reflects aimed by the project team increased efficiency of the RCRF layout.

Existing Conditions and Site

The parcel of land allocated to RCRF on South Campus was defined as Site #3 of Sector 12, District 2. For the purpose of defining a development boundary, the project site measuring 184 m x 81 m has been established, approximately 14,900 m² (3.68 acre) in area, and coordinated with the South Campus planning (refer to the images to the right).

The site D-2 #3 has been selected for reasons of access, alignment with utility planned Right of Way and manageable impact to current research and operations for the Faculty of Agricultural, Life and Environmental Sciences. The specific zone for current development is delineated by two rows of trees, acting as wind breakers. The RCRF project is to be contained between those four elements to further minimize development impact and respecting its siting context. No construction activity is to take place south of the existing south tree line.

Other conditions impacting the site development is an existing General Storage facility and associated with it service yard and parking immediately adjacent to the north. This condition is noted in consideration of the limiting distance and the exposing walls, as defined and governed by Alberta Building Code. The General Storage building is a Butler-type metal structure with no openings facing south, however it does not appear to provide any fire rating, which should be considered in development of the RCRF.

Topography

The site topography is almost flat with a minimal and uniform slope towards the north. This condition is noted in creating an effective surface drainage management around the new RCRF building and its landscaped areas. The present use appears to be one of the farmed land.

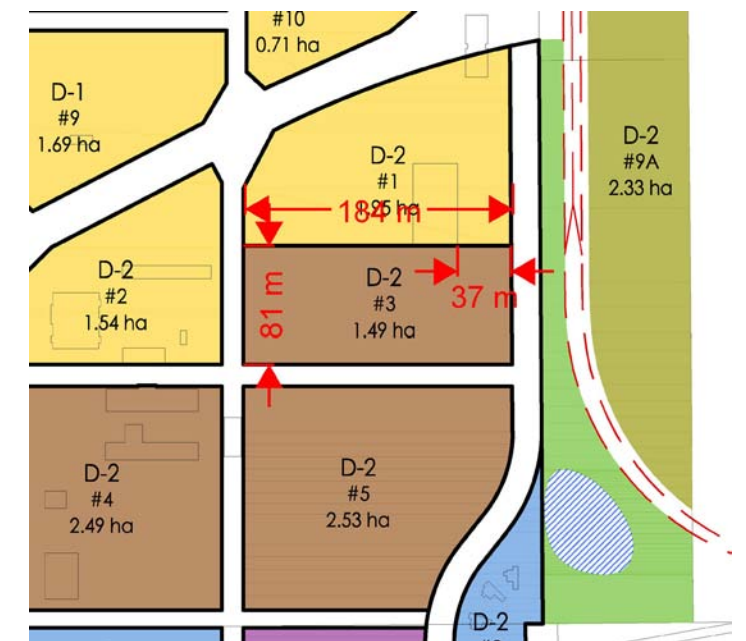

Parcel D-2 #3 Site Dimensions

Wind

Edmonton is in the zone of the upper level westerlies, a large-scale atmospheric circulation that generally streams in a west to east direction. In the winter, this flow shifts to northwesterly or northerly which allows for frequent invasions of cold Arctic air. In the summer, a more westerly or southwesterly upper flow allows for incursions of moist Pacific air. Winds are typically lighter in winter than those during the rest of the year. However, a combination of fresh snow, wind and cold temperatures may result in blizzard conditions, but these events are rare in Edmonton. The winds become somewhat stronger in the spring and summer and favour a west to northwest direction.

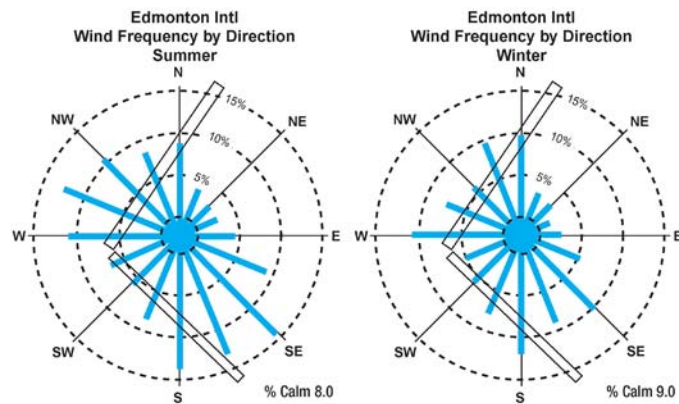

Wind Rose Data, Edmonton, AB (Source: Nav Canada)

Average Temperatures

- The mean temperature in Edmonton, Alberta, Canada is cool at 3.6 degrees Celsius (38.5 degrees Fahrenheit).
- Mean monthly temperatures have a variation of 30 °C (54°F) which is above moderate range.
- There is a variation/ range of daily average temperatures of 10.2 °C (18.4 °F).
- July is the warmest month (very mild) having an average temperature of 17.5 degrees Celsius (63.5 degrees Fahrenheit).
- January is the coolest month (very cold) having a mean temperature of -12.5 degrees Celsius (9.5 degrees Fahrenheit).

Precipitation Table (Source: ClimaTemps.com)

	Jan	Feb	Mar	Apr	May	Jun	Jul	Aug	Sep	Oct	Nov	Dec	Annual
Average Precipitation mm (in)	23.3 (0.9)	16.8 (0.7)	17 (0.7)	22.1 (0.9)	43.5 (1.7)	79.9 (3.1)	94.3 (3.7)	67 (2.6)	41.6 (1.6)	17.3 (0.7)	16.1 (0.6)	22.2 (0.9)	461.1 (18.2)
Precipitation Litres/m² (Gallons/ft ²)	23.3 (0.57)	16.8 (0.41)	17 (0.42)	22.1 (0.54)	43.5 (1.07)	79.9 (1.96)	94.3 (2.31)	67 (1.64)	41.6 (1.02)	17.3 (0.42)	16.1 (0.39)	22.2 (0.54)	461.1 (11.31)
Number of Wet Days (probability of rain on a day)	11 (35%)	11 (39%)	10 (32%)	8 (27%)	9 (29%)	13 (43%)	13 (42%)	12 (39%)	9 (30%)	7 (23%)	8 (27%)	11 (35%)	122 (33%)
Percentage of Sunny (Cloudy) Daylight Hours	37 (63)	39 (61)	46 (54)	51 (49)	55 (45)	49 (51)	61 (39)	58 (42)	49 (51)	50 (50)	41 (59)	35 (65)	50 (50)

Rainfall/ Precipitation

- Edmonton, Alberta is procured on average 461.1 mm (18.2 in) of rainfall per year, or 38.4 mm (1.5 in) per month.
- On average there are 122 days per year with more than 0.1 mm (0.004 in) of rainfall (precipitation) or 10.2 days with a quantity of rain, sleet, snow etc. per month.
- The driest weather is in November when an average of 16.1 mm (0.6 in) of rainfall (precipitation) occurs.
- The wettest weather is in July when an average of 94.3 mm (3.7 in) of rainfall (precipitation) occurs.

Average Temperatures Table (Source: ClimaTemps.com)

	Jan	Feb	Mar	Apr	May	Jun	Jul	Aug	Sep	Oct	Nov	Dec	Annual
Average Max Temperature °C (°F)	-8.2 (17.2)	-4.2 (24.4)	1.1 (34)	10.5 (50.9)	17.5 (63.5)	21.3 (70.3)	23 (73.4)	22.1 (71.8)	16.6 (61.9)	11.3 (52.3)	-0.1 (31.8)	-6.3 (20.7)	8.7 (47.7)
Average Temperature °C (°F)	-12.5 (9.5)	-8.9 (16)	-3.6 (25.5)	4.9 (40.8)	11.6 (52.9)	15.6 (60.1)	17.5 (63.5)	16.6 (61.9)	11.1 (52)	5.9 (42.6)	-4.2 (24.4)	-10.5 (13.1)	3.6 (38.5)
Average Min Temperature °C (°F)	-17 (1.4)	-13.7 (7.3)	-8.4 (16.9)	-0.7 (30.7)	5.7 (42.3)	9.9 (49.8)	12 (53.6)	11 (51.8)	5.6 (42.1)	0.6 (33.1)	-8.4 (16.9)	-14.8 (5.4)	-1.5 (29.3)

Site Geotechnical

The south campus site is located in an area containing high plastic soils and a relatively high water table. This poses a significant risk for swelling and shrinkage behaviour in the soil matrix with changes in soil moisture content. The initial six geotechnical test bores confirm this condition. In combination with a minimal slope of the existing site topography, the surface water and the soil moisture management are significant considerations reflected in the Schematic Design.

Site Specific Development Guidelines

The initial development parameters for the site D-2 #3 were applied as the guidelines informing RCRF project design siting and design. Based on the revised and reduced in size site area of 14,900 m² (3.68 acre), at the Schematic Design those resulted in the following outcome:

Criterion	Site Specific Development Guidelines for D2-#3	Site Specific Development Guidelines for D2-#3	RCRF Schematic Design
Floor Area Ratio (FAR)	1.0	0.35-0.7	0.27
Site Coverage	80%	70%	25%
Setbacks			
Front:	15.0m	10.0m	10.5m
North:	14.0m	10.0m	11.0m
South:	22.0m	10.0m	23.0m
Back:	53.0m	10.0m	79.0m
Permeability			
Front:	35%	35%	39%
Back:	5%	5%	≤ 0.1%
Height at Ridge	18.3 m (60 feet)	18.3 m (60 feet)	14.7 m (48 feet)

The noted Permeability for the “back” of the RCRF building is very low and reflects the functional requirement of effectively preventing the daylight (UV in particular) from reaching the collections area and in result damaging the stored material that requires protection. Only very limited and measured daylight access has been granted to the collections warehouse through strategic location of narrow windows, which correspond with the main racking aisles.

Summary of Options

The Schematic Design and validation phase involved exploration of various site and building development options to balance LDRP and Sector 12 long range planning criteria with functional and operational requirements of RCRF. Over the course of few weeks a total of seven siting options were developed and assessed identifying Pros and Cons, anticipated relative cost impacts, opportunities created and potential limitations brought about each of the planning approaches. The resulting analysis allowed more detailed determination of the RCRF placement, which was to:

- occupy the northeast area of the D-2 #3 site;
- provide for separate access points for visiting researchers and students and away from the vehicular deliveries traffic;
- eliminate of the on-site staff parking;
- create opportunities for public real engagement;
- preserve, where possible, the existing natural site features (trees);
- consider impact of the prevailing winds and the sun path on design;
- take advantage of the LRT Station and public multi-use path proximity;
- provide for future expansions largely available to the west;
- mitigate the massing impact of the high density storage volume.



WORKSHOP DESIGN SESSION SEP 17, 2015

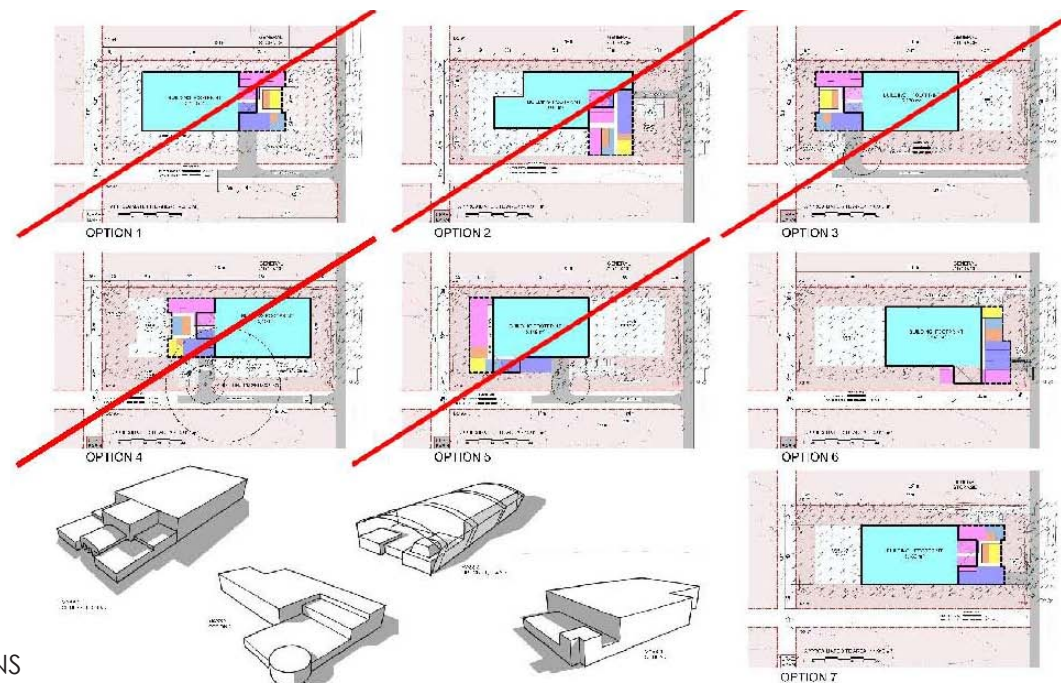

SITING OPTIONS

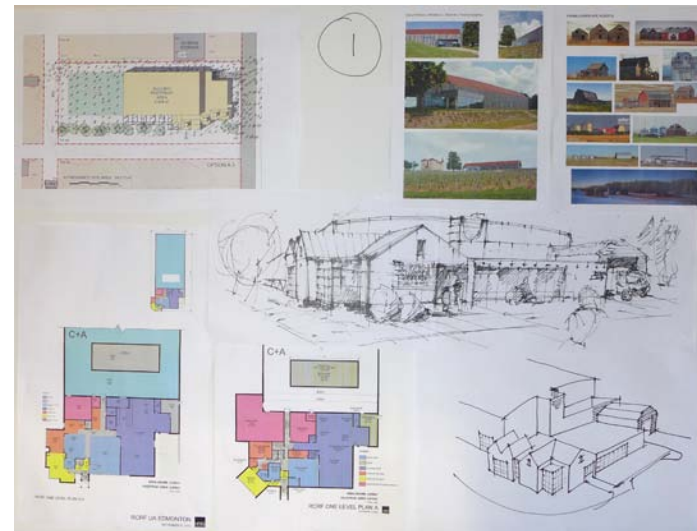

OPTION A PRELIMINARY SKETCH

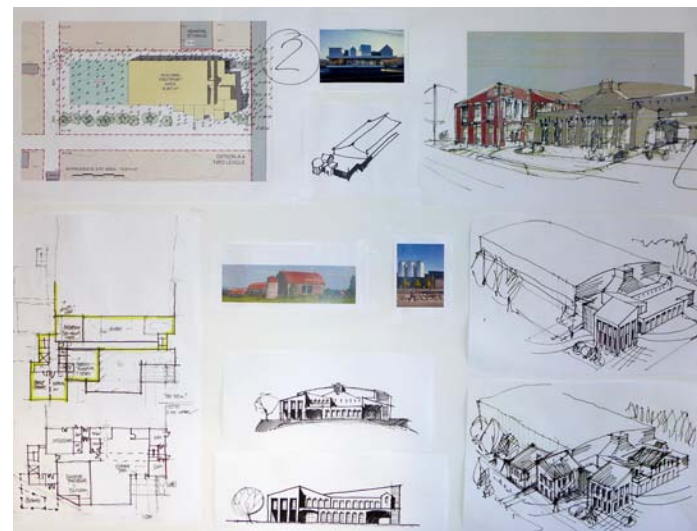

OPTION B PRELIMINARY SKETCH

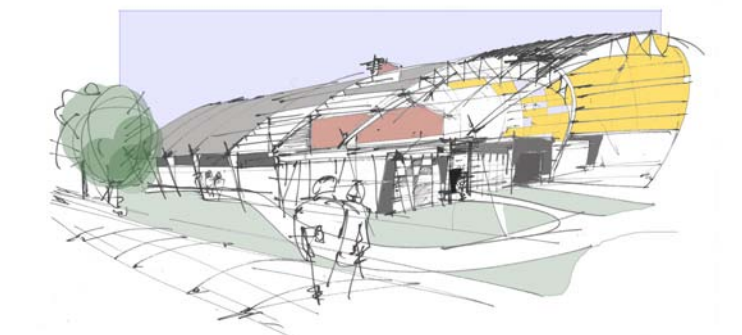

OPTION C PRELIMINARY SKETCH

CONCEPT OPTIONS

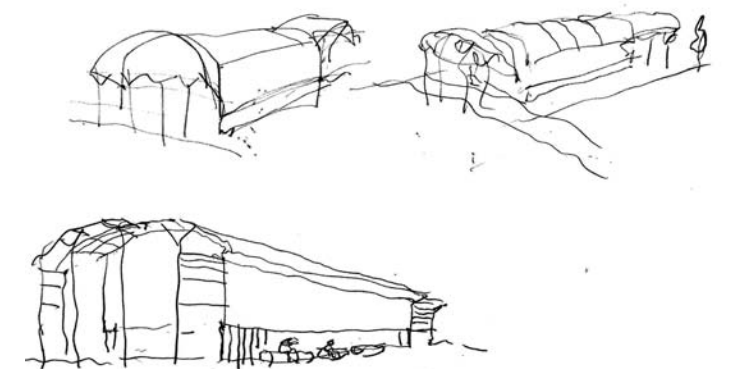

MASSING STUDIES

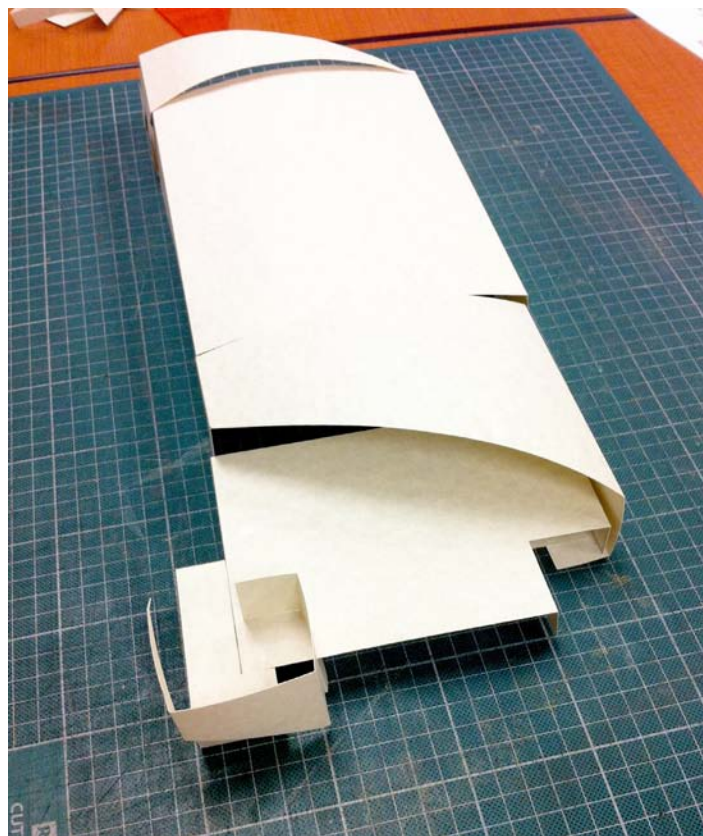
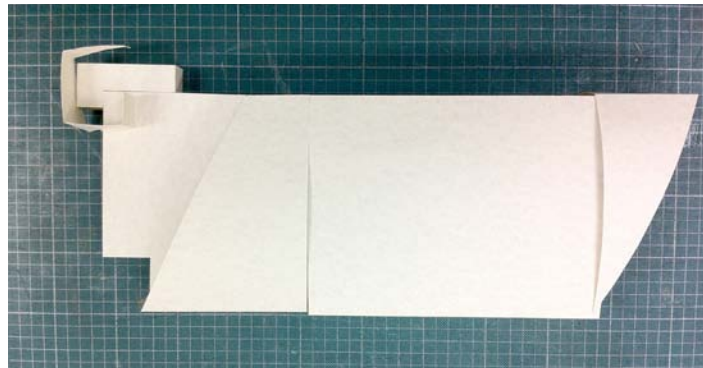
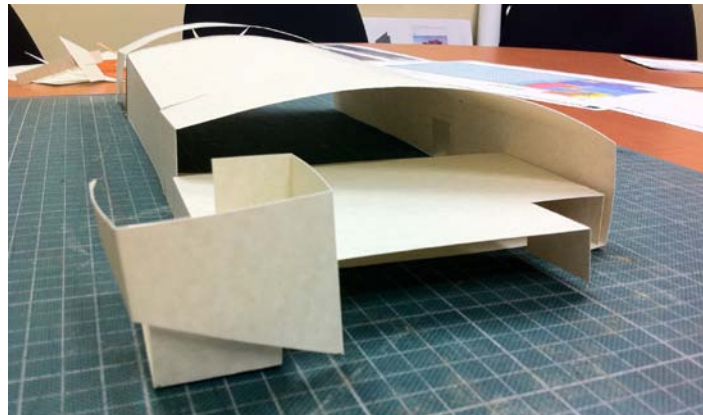

WORKING MODEL VIEWS



OPTION A DEVELOPEMENT

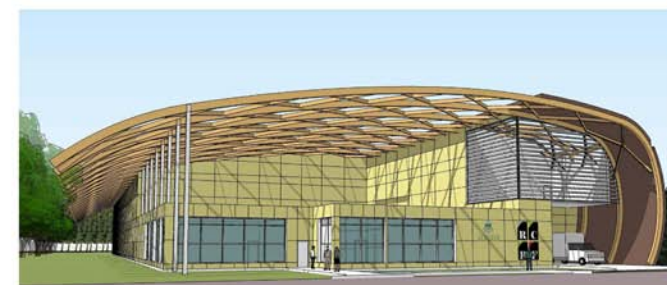
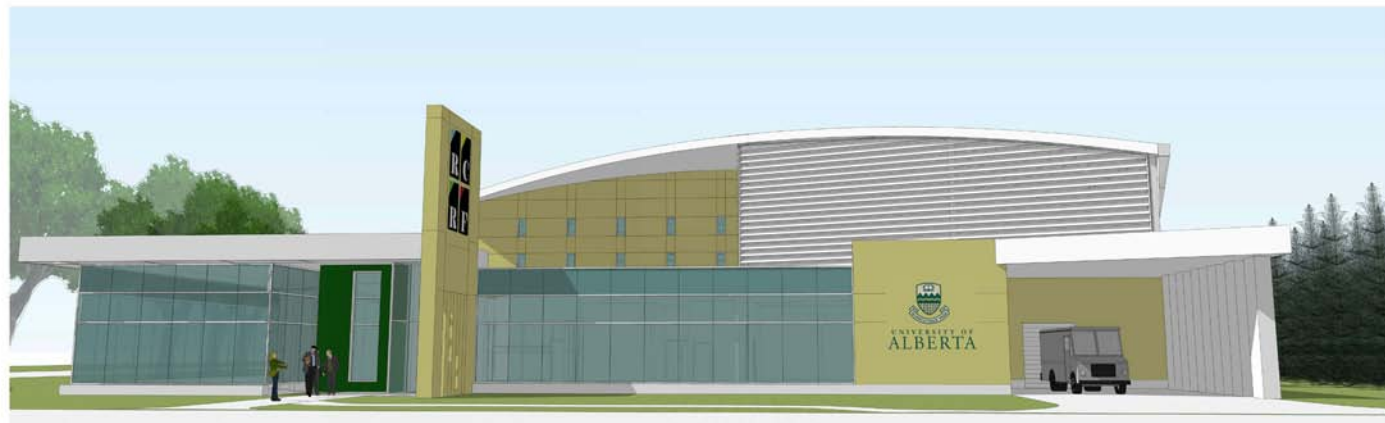
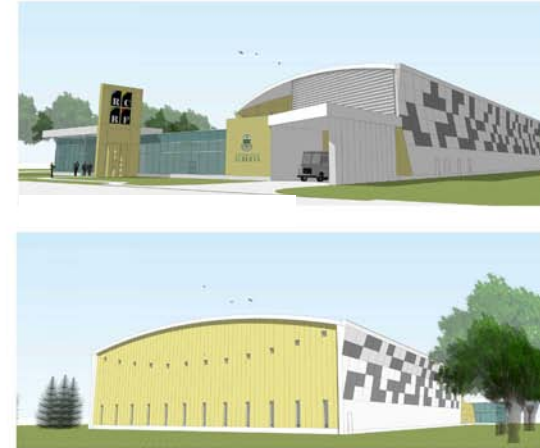

OPTION C DEVELOPEMENT



With the facility placement determination, more advanced designs were developed to meet LRDP criteria following the input offered at the Community Open House #1, which occurred at the end of July 2015 and the on-going IPD process with participation of the University of Alberta teams. Three design options were further developed and presented, all of which based on approved design direction to face front of house operations towards the 115A Street and taking advantage of the service access placement close to the site north boundary. The following options were discussed, assessed and cost estimated:

- OPTION A – single storey front of house with separate high density storage roof enclosure;
- OPTION B – two-level front of house with separate high density storage roof enclosure;
- OPTION C – single level front of house with continuous roof enclosure for the entire facility.

It has been determined that while the two-storey approach results in a reduced footprint of the front of house component, an introduction of two functional levels had not produces sufficient advantages both operationally, and from the construction cost points of view. This eliminated further exploration of Option B. Another round of more detailed costing has been conducted by Stuart Olson cost estimating department for Options A and C, which concluded correspondingly that while both approaches projected higher than anticipated construction costs, the Option C become less likely to stay within budgetary parameters established by university for the RCRF project. The direction provided to the DB Team was to pursue the approach and to advance schematic design of Option A to the Design Development phase.

Design Concept

The design concept has been developed through the guidance of the campus wide land use and design guidelines, district specific design guidelines and site specific development guidelines. In addition, the approach to concept design was also informed by the parameters presented by UA at an Open House held on 27 July 2015.

Contextual Design

The building concept is formed both functionally and physically by a pattern of long and narrow farmland, framed by treed windbreakers punctuating the existing pattern of fields or former homesteads. A longitudinal plan composition implements a dialog between the edge of the Sector 12 and its future Public Realm development that in time will intensify towards the campus centre. The function of the facility informs its elongated configuration to occupy the land parcel that was shaped by farming tradition of working the field in the most economical pattern. A similar pattern of work and operation repeats itself within RCRF facility storage and enclosed protective environment. It evokes the function of a connection, transmitting evolutionary change of the land use from the edge towards the future centre.

A contextual, dominating form sources elements of practical, common sense farm facilities that store and protect the crops. The massing assembly sets the stage for public realm engagement along its east and west edges to balance unique operational requirements of RCRF with the specified site design guidelines. The main pedestrian entrance and service approach are located along the east edge of the building to take advantage of already established 115A Street access. The east-facing front of the house is not greater than two levels above grade to begin with and increases its volume towards the future campus centre. Such orientation supports design principles of the Winter Cities protecting pedestrian and delivery entry points from prevailing cold northern and northwestern winds.

Spatial Organization

The planning of the facility has been driven by the composition of three major components: the large Collections storage volume, a processing area and a reading room. The massing, scale and articulation of the three components is critical in defining the function and use of the facility, while providing an appropriate architectural expression in the context of South Campus. Architecturally, the front of house components has

been developed as a low volume pavilion which sits in front of the Collections space. The use of materials and the lighting concepts support a building that will initially be viewed from the east, as they arrive at the adjacent South Campus/ Fort Edmonton Park transit station, as well as to the Saville Community Sports Centre. A description of the organization of the three major components is provided.

Collections Space:

The Collections space is a three-storey volume is located to the west and, as described functionally in the previous section on Program Analysis, accommodates 30' high racking for the proper storage of materials. This space is maintained under separate environmental controls. A large structure and volume is required to accommodate the Collections. In order to minimize the impact of such a large volume on the site, there is an architectural language expressed to soften its impact on South Campus. The large, sweeping barrel roof provides a lower roof profile while ensuring that roof penetrations are minimized. Rainwater will not accumulate on a curved roof as it would on a flat roof. Gutters and exterior downspouts become part of the roof profile and elevation detailing on both the north and south facades, providing vertical articulation. A change in colour and materiality along the top portion of these two facades draws the eye up above the tree lines.

Reading Room:

The east end of the building contains the 'front of house' components. This is not an open, public building but the Reading Room is a space that would have limited public engagement and support academic research on South Campus. Located at the southeast corner, this space is articulated as a one and a half storey volume. The glazed façade offers views to one of the current access points to South Campus and enough sun shading to practically provide protection to the items from the Collections space that will be viewed in this space by researchers. A low, long roof overhang provides additional shading during the day but there is also the opportunity to light the underside of the roof to provide a glow of the facility at night.

Processing Area:

The Processing Area is the working hub of the facility. There is a relatively low number of staff to be accommodated in this facility and most of their daily work occurs in the spaces within the Processing Area. This includes the receiving of the

Collections material, the required cataloguing and then the proper storage. These activities also happen in reverse, when an item from the Collections is called for retrieval. The volume required to accommodate these functions is primarily one storey, with the exception of the loading dock, which is a one and a half storey volume. This space is accommodated to the northeast portion of the site. The roof canopy over the loading bay also provides a lighting opportunity, echoing a similar detail to the south and emphasizing the notion of a pavilion-like structure.

Main Entry:

The major entry point to the facility for staff, visitors and researchers is just north of the Reading Room on the east side of the building. The entry vestibule is pulled in to provide additional shelter for the entry. Directly to the north of the entry is a vertical element approximately two stories high which provides a marker for the entry.

Floor Plan Layouts

The composition of the three main functional components (Collections space, processing area and reading room) is the major driver in the development of the floor plans at the schematic design stage. The details of the various programmed spaces are addressed in the previous section, Program Analysis. It is understood that some floor plan refinement will be required through the Design Development stage.

There is a second level in this facility, which accommodates the mechanical and electrical functions. In order to provide supply air ductwork in the Collections space at the highest possible elevation (integrated within the building structure) the mechanical space on the second level has an integral mezzanine. This concept reduced the overall footprint of the mechanical space but maximized the volume to better accommodate the mechanical components.

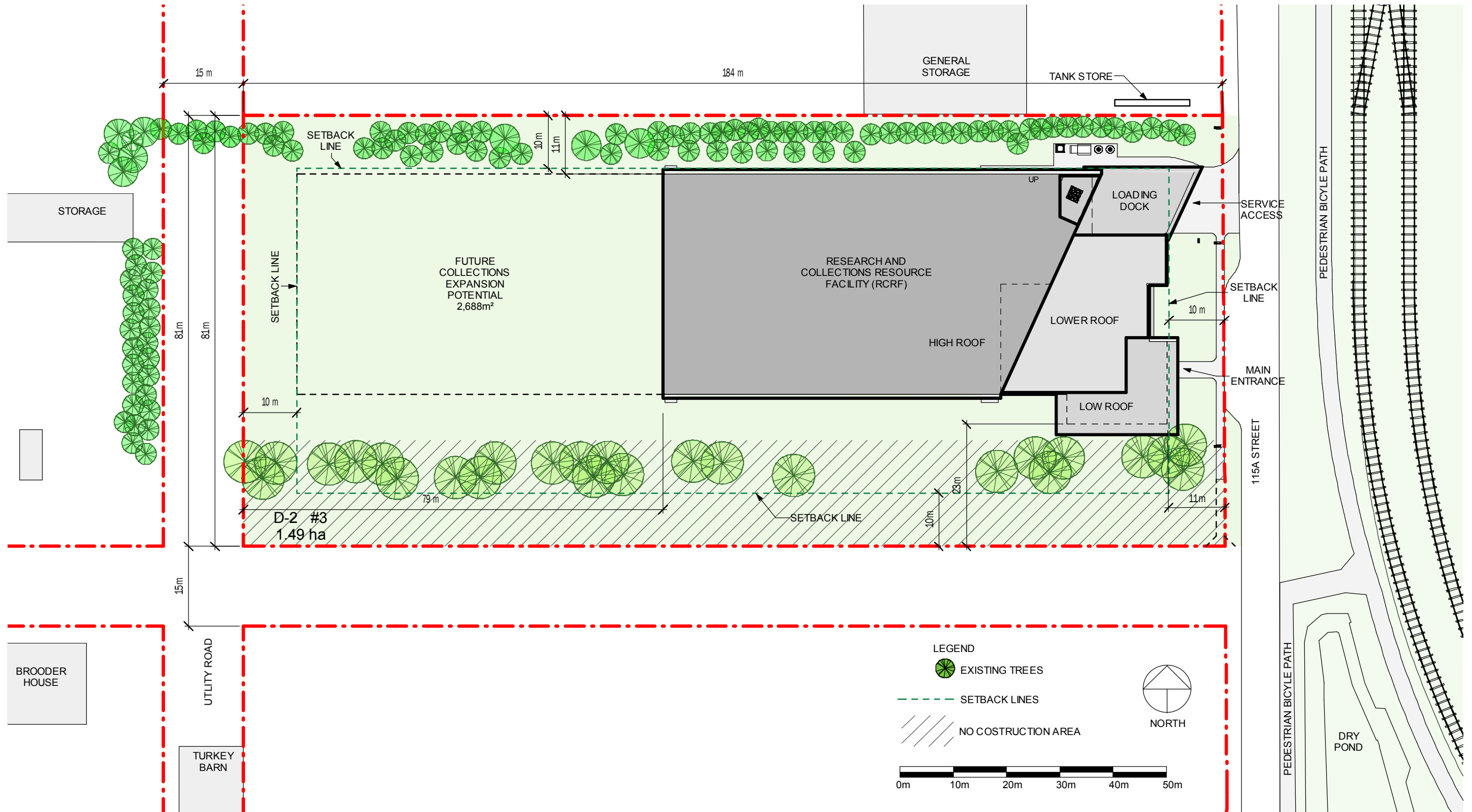

SITE PLAN 1:300

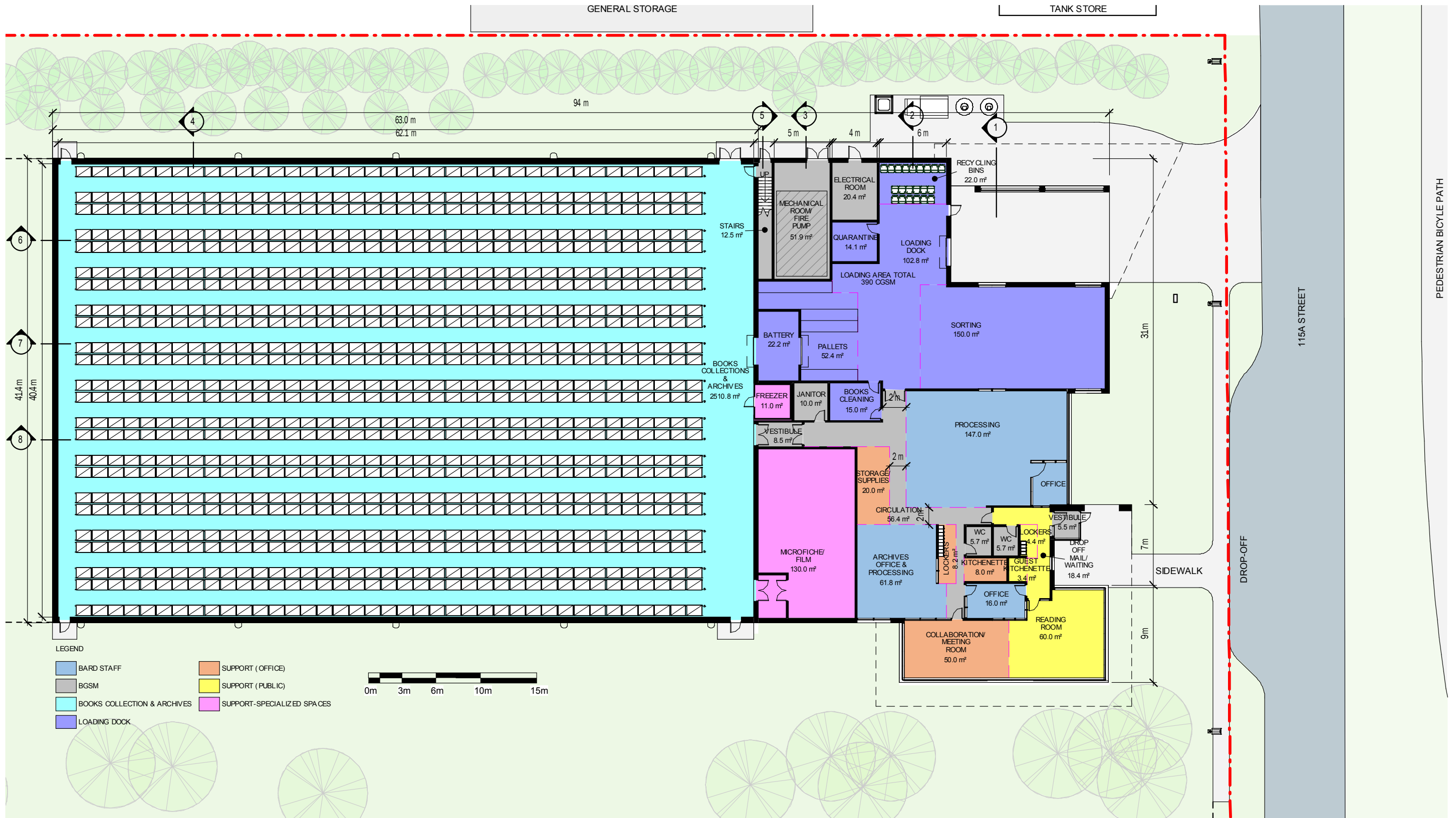

MAIN FLOOR PLAN 1:300

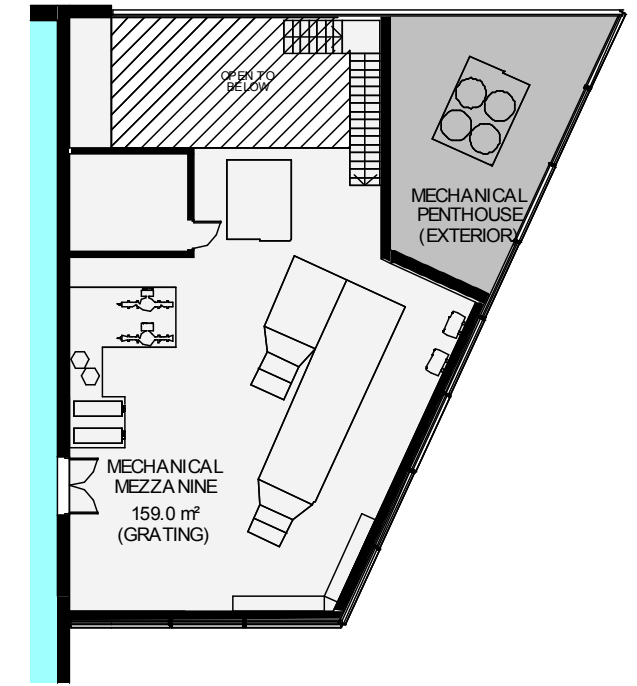
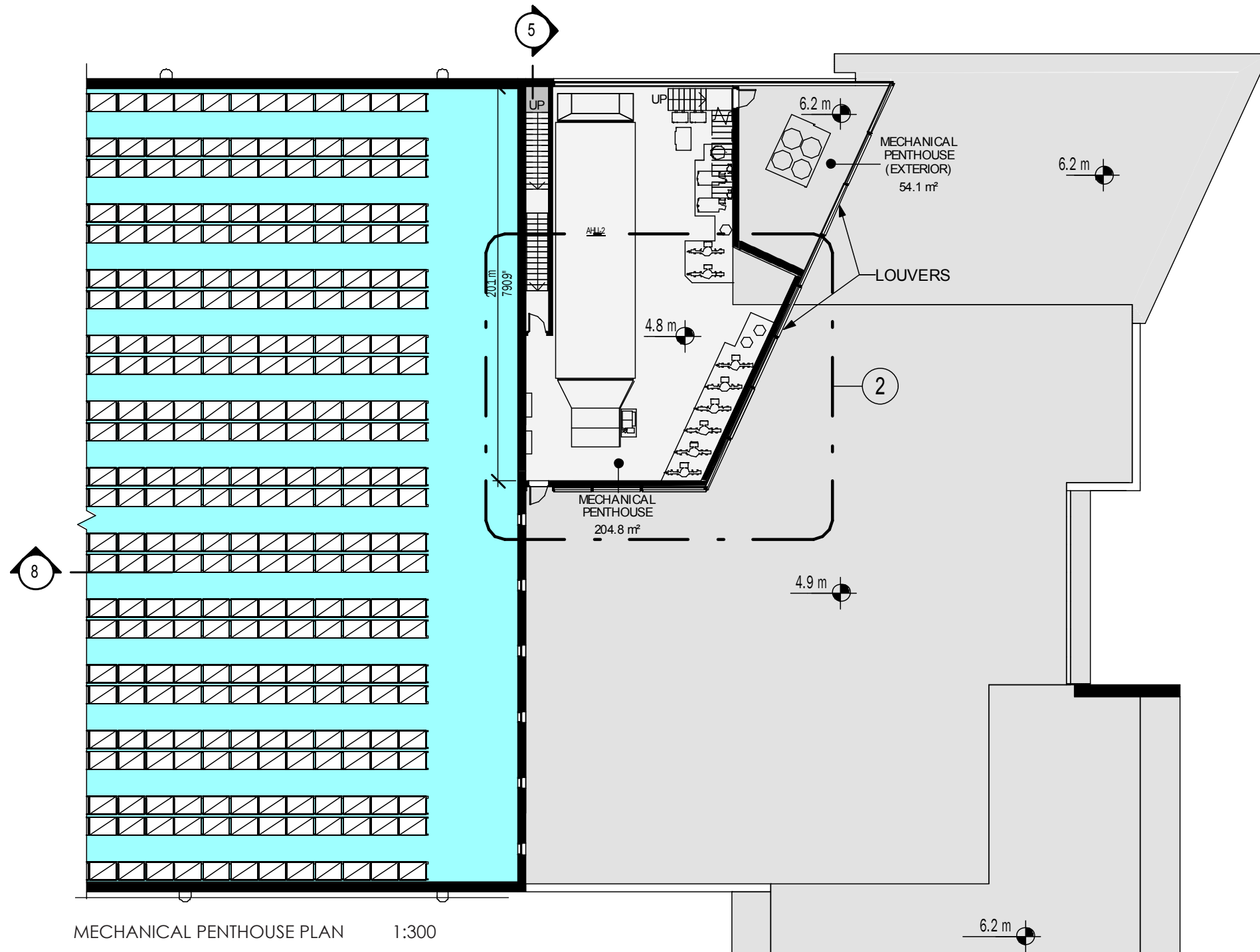

MECHANICAL MEZZANINE PLAN 1:300

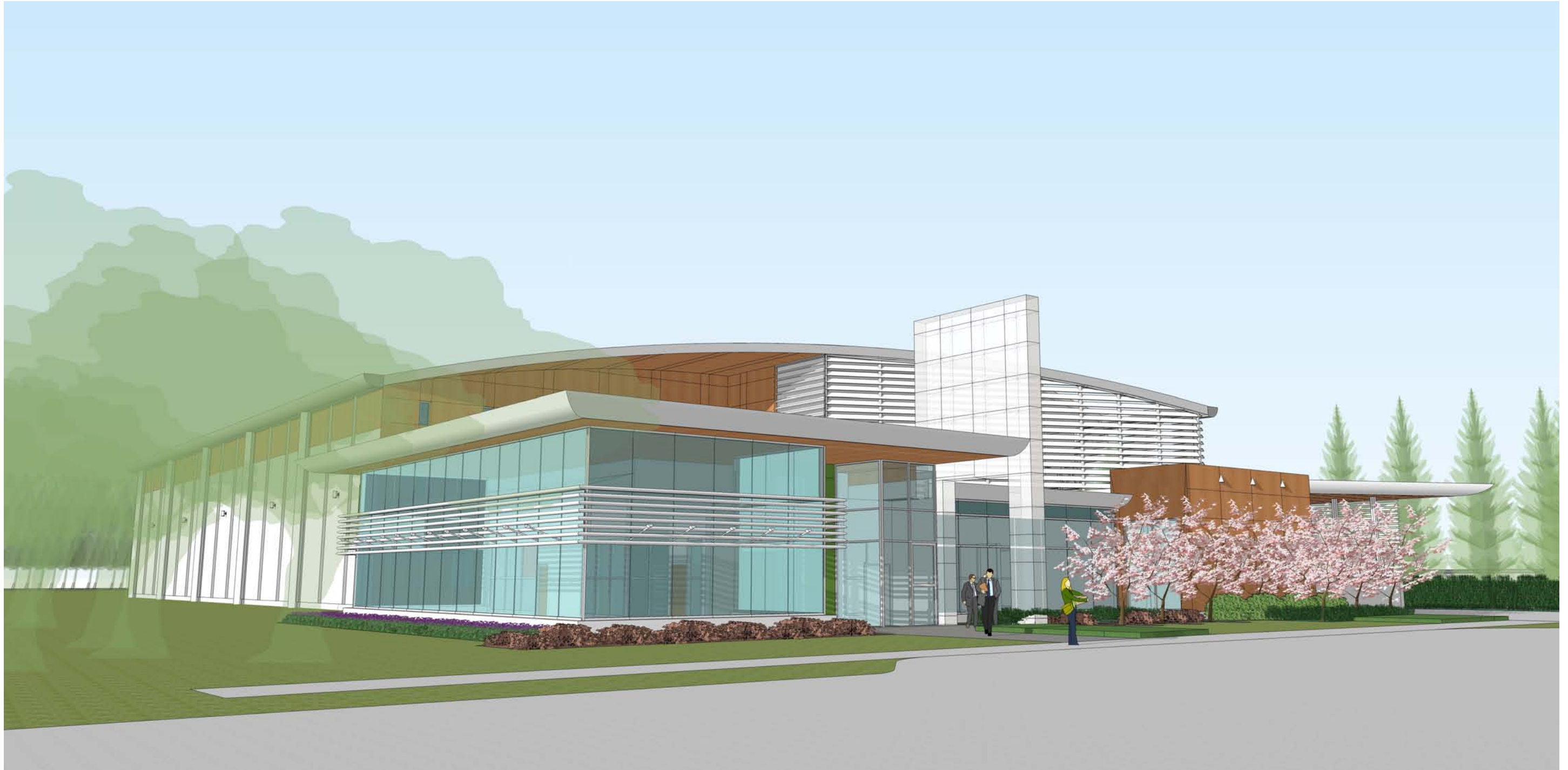

SOUTH-EAST VIEW



EAST ELEVATION

Materiality

A clean, simple palette of materials is proposed for RCRF. As the largest volume, the Collections space has the most stringent environmental controls and it is important that the exterior envelope be designed and detailed in such a way that the cladding system is cleanly installed and easily maintained. An insulated metal wall system is proposed, whereby modular 40 foot sections can be installed, minimizing the number of joints. This system is considered an all in one system with interior finish, insulation and exterior finish are integral to the panels. The proposed system offers a high performance solution, engineered to provide a stringent R-value and meet energy bridging requirements. It is considered the most cost effective cladding system for this large volume. It is possible to modulate the cladding panels and finishes on the exterior. For example, it is planned to change the colour and finish of the upper fifth portion of the north and south elevations (above the tree line) for visual interest.

The front of house pavilion is planned to be a combination of curtain wall (both vision and spandrel panels), metal panel and a wood-look metal panel. The soffit material would also be a wood-look metal system. The other dominant material is a metal louvre at the upper level mechanical room, but also repeated as a sunshade at the Reading Room and as a screen at the north loading bay.

The vertical entry plinth is envisioned as either a translucent or opaque glass-clad structure that is lit from within, providing additional glow from the building.



NORTH-EAST VIEW

Lighting Concepts

This building has been developed for its functional requirements, but also how it will be perceived by those individuals who live and work in and around South Campus. Particular attention will be paid to the lighting methodologies that can be incorporated in order to enhance this building as day turns to night. The initial concept is to have the large volume recede as evening falls and then skillfully light the remaining pavilion-like structure. This building will be seen by neighboring facilities as well as the LRT passenger.

As previously mentioned, some lighting features that are envisioned include:

- Wall-washing LED wall packs on the exterior elevations, all sides.
- Soffit lighting along the east façade – under the Reading Room canopy and the loading bay canopy.
- Soffit lighting at the main east entry.
- Vertical entry plinth as a 'lantern'.
- All possible lighting methods will be cognizant to avoid increasing 'light pollution'

Sustainable Design

As per the UA project objectives, there is a target established for the team to achieve Green Globes certification, providing a sustainable building initiative. As of the writing of this report, the design team has completed an initial project questionnaire. Some architectural considerations include:

- Efficiency in the building envelope
- Siting and orientation of the building
- Energy model targets
- Selection of products and materials that meet sustainable design criteria
- Consideration in developing a Building Service Life Plan



SOUTH-WEST VIEW

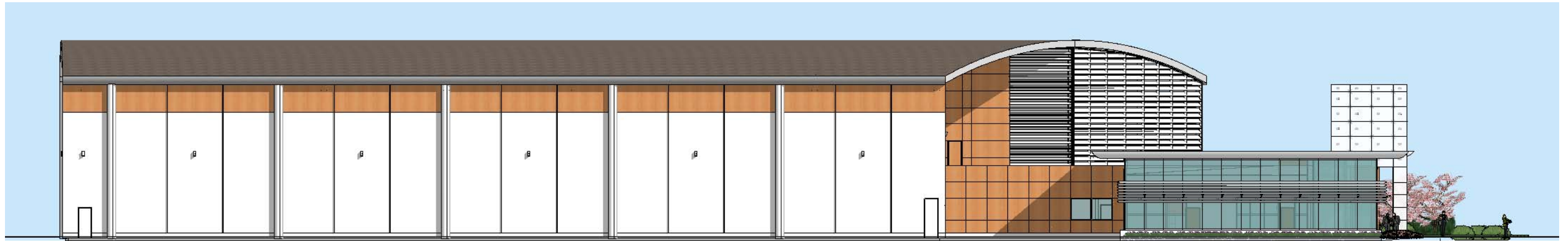

SOUTH ELEVATION 1:300

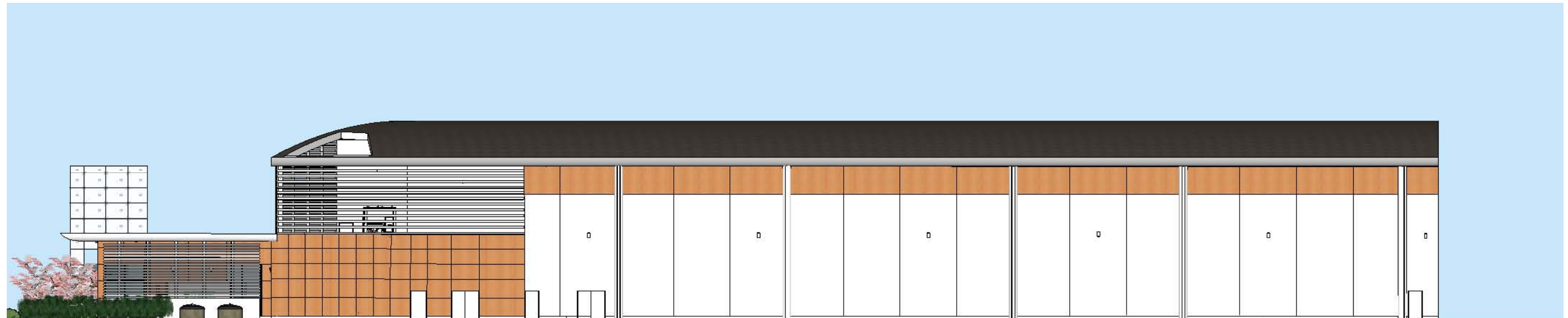

NORTH ELEVATION 1:300

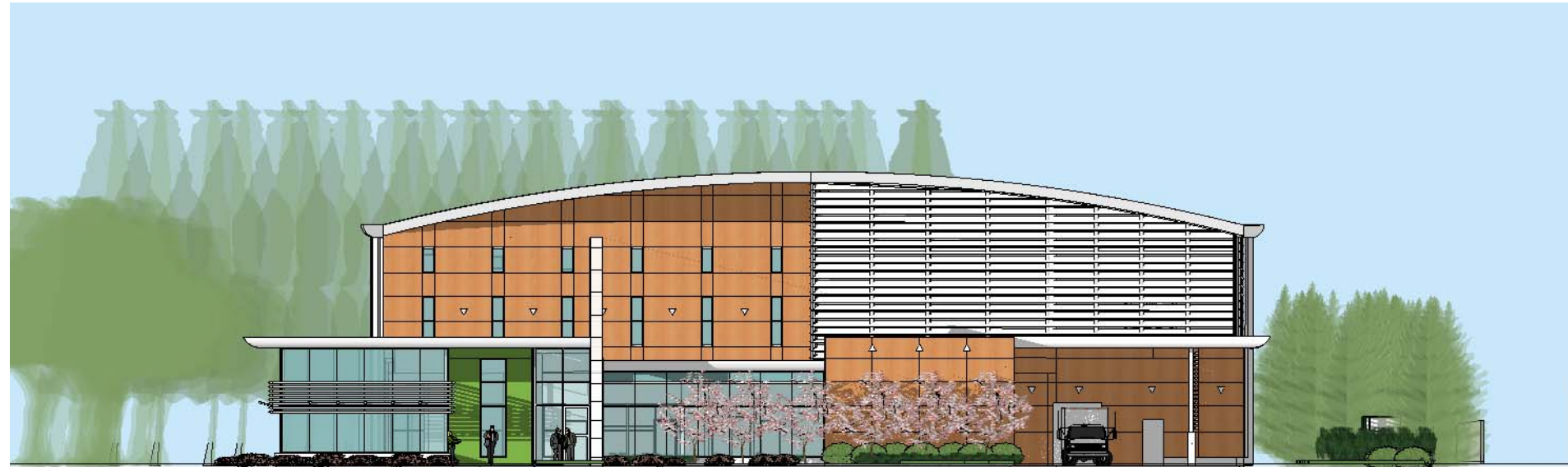

EAST ELEVATION 1:300

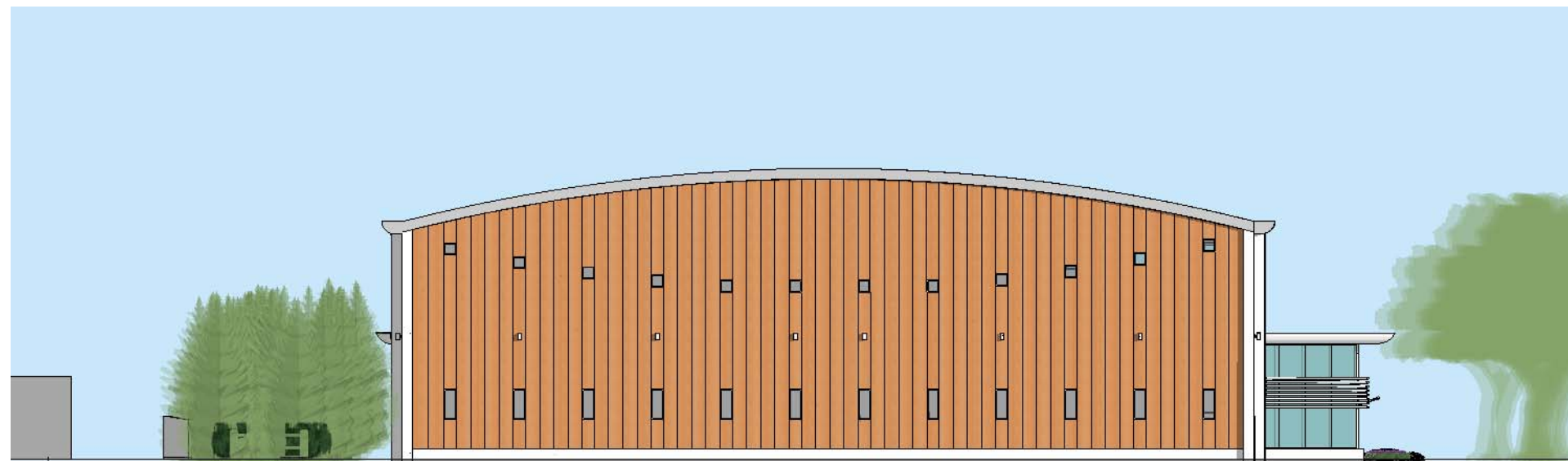

WEST ELEVATION 1:300

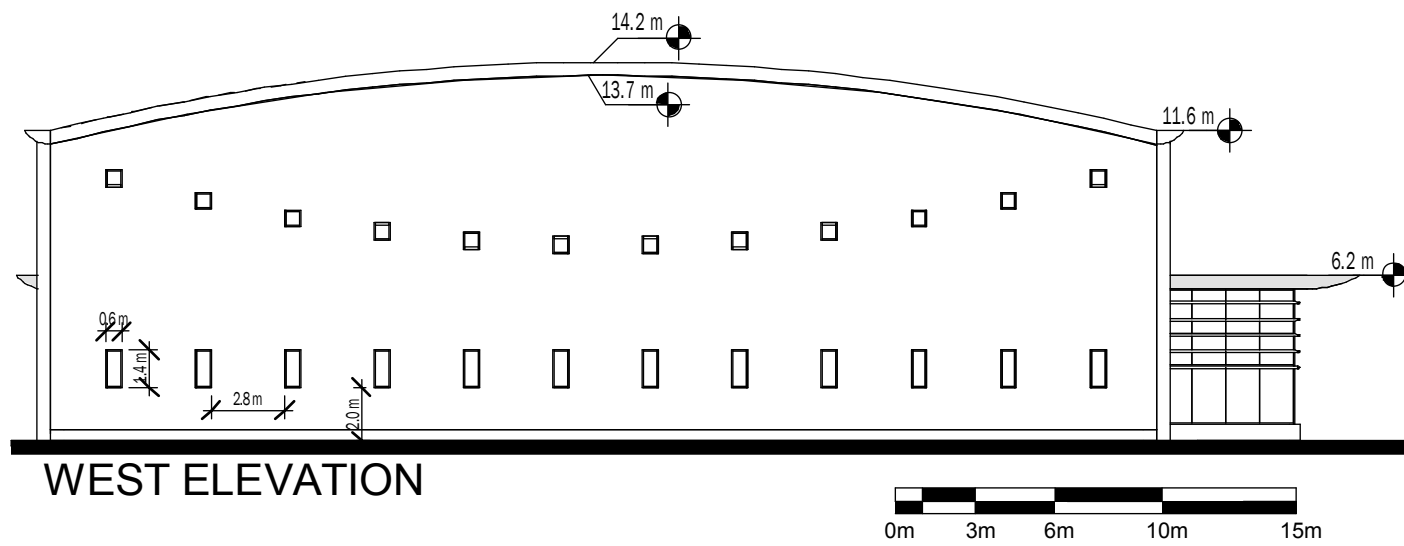
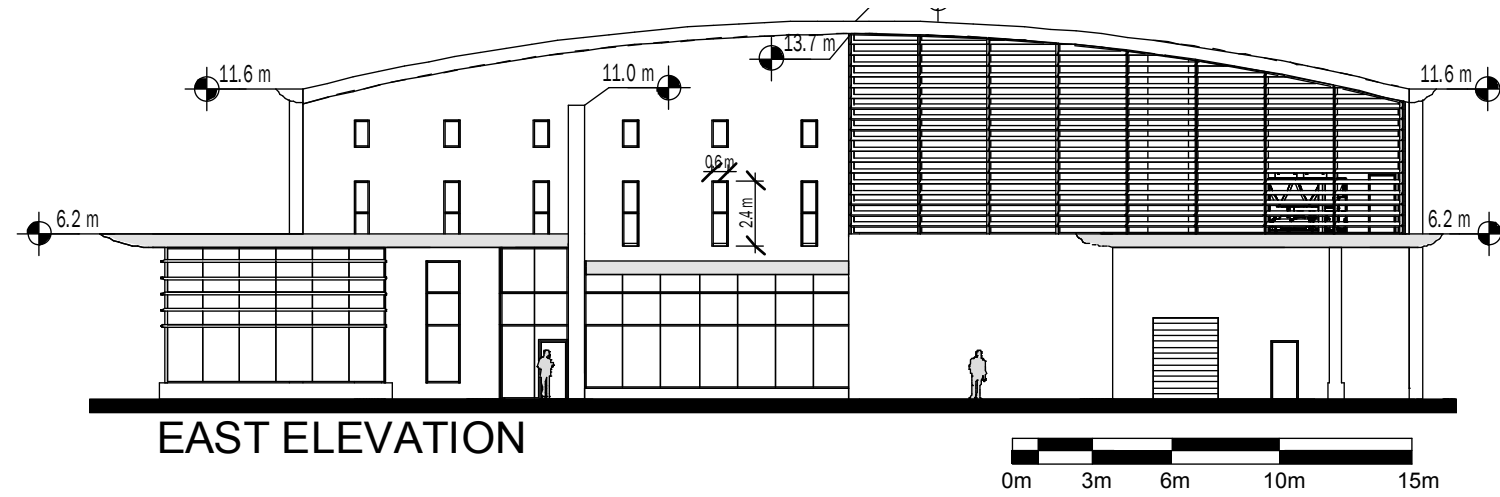

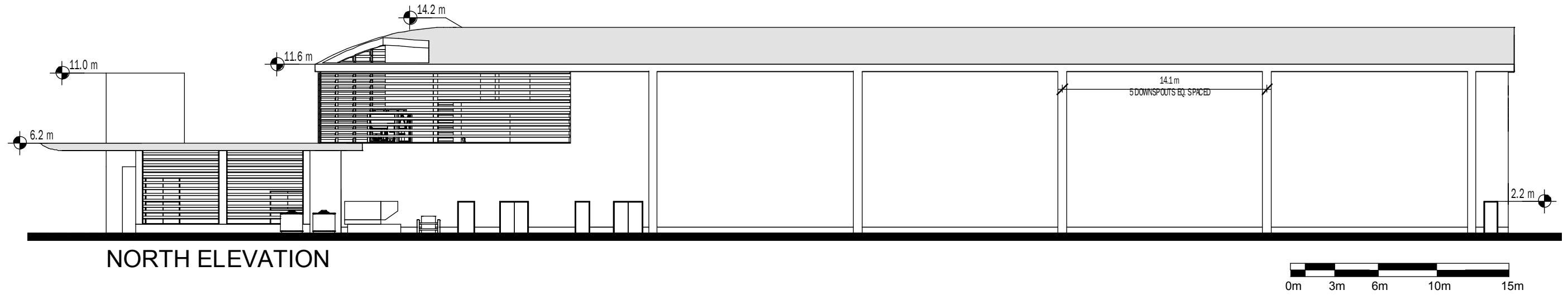

NORTH ELEVATION

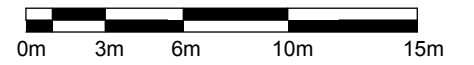

0m 3m 6m 10m

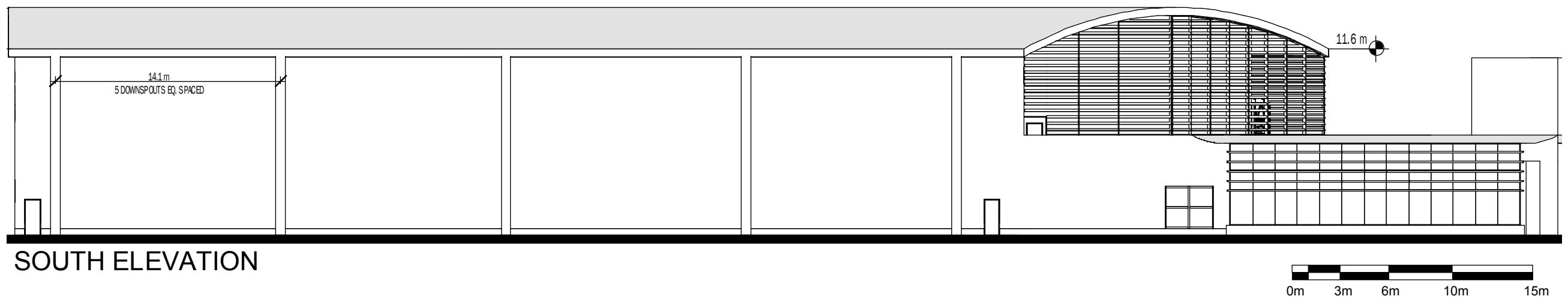

SOUTH ELEVATION

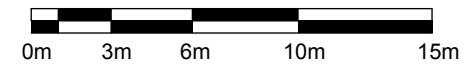

2.0 ARCHITECTURAL

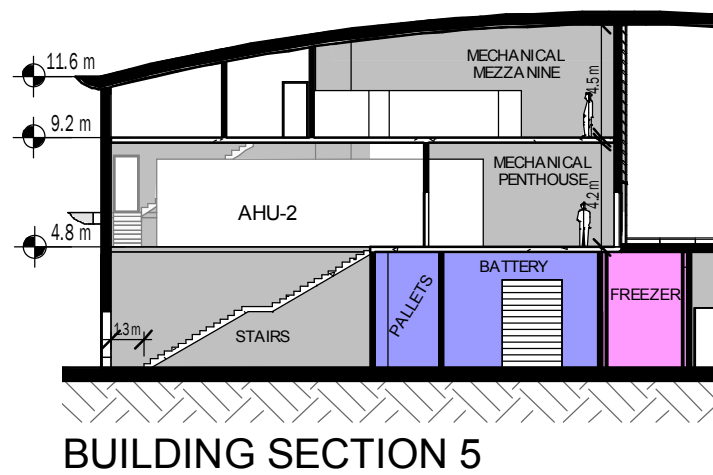
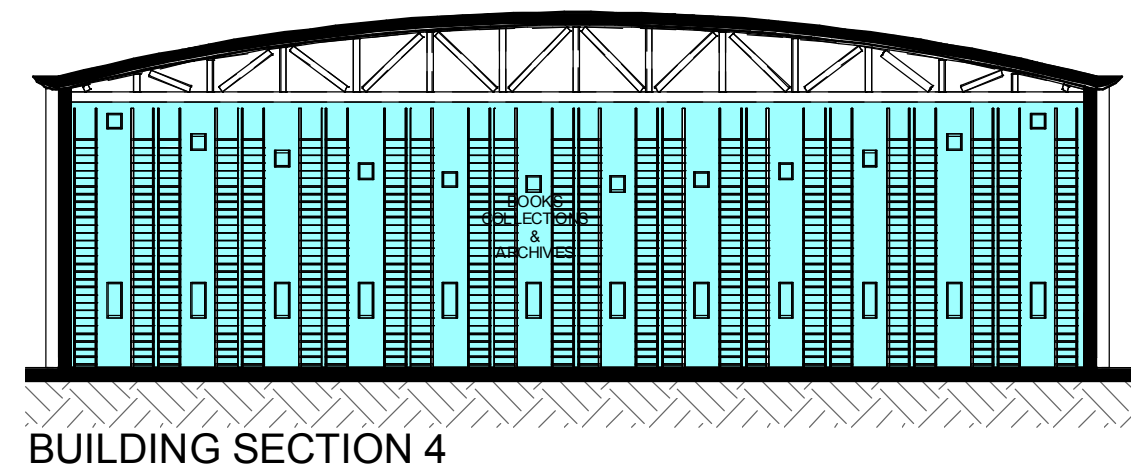
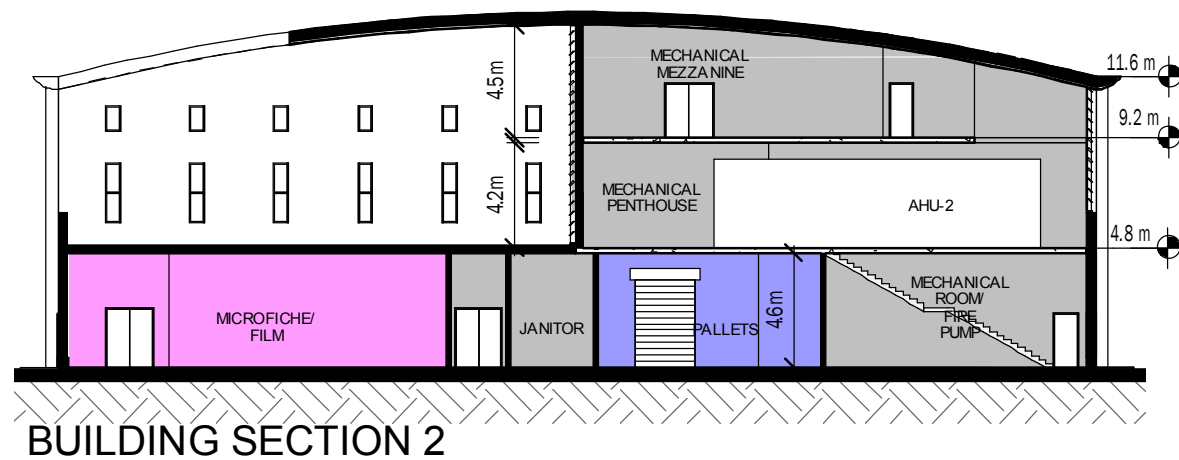
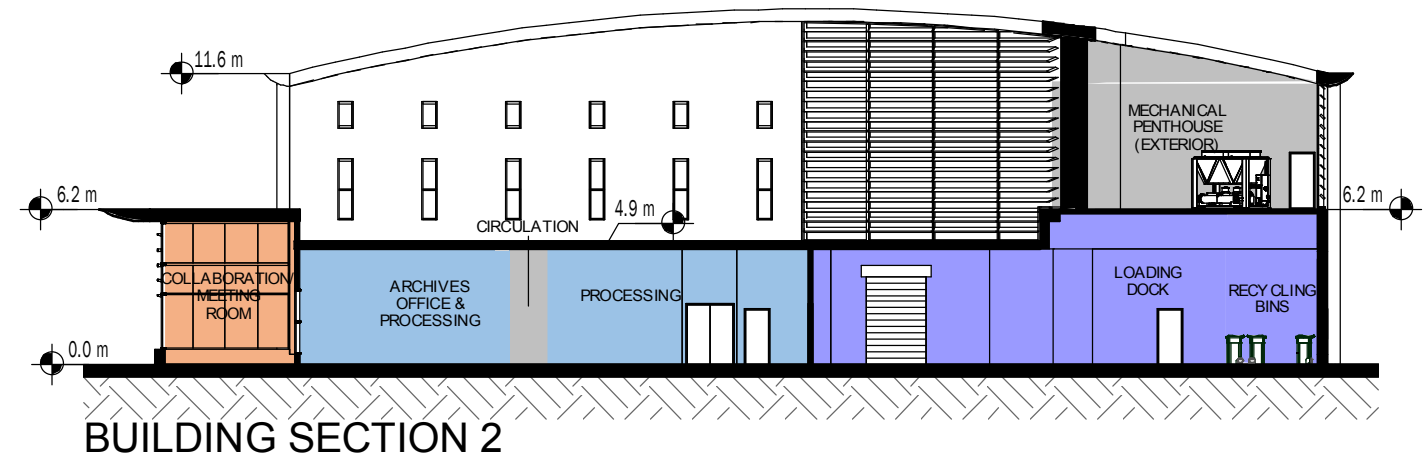
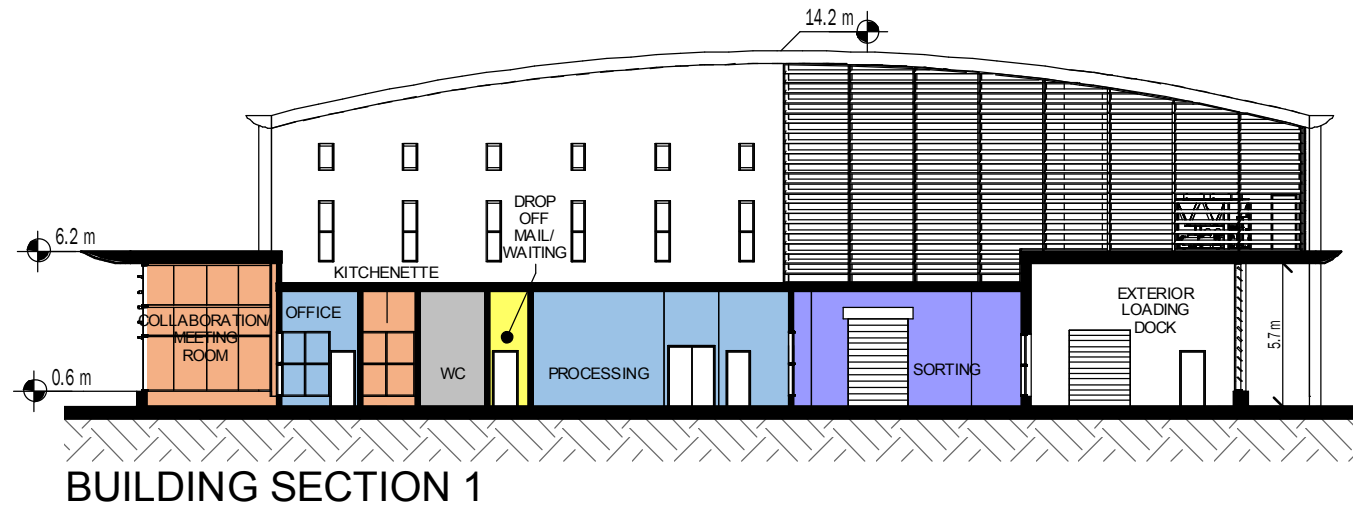

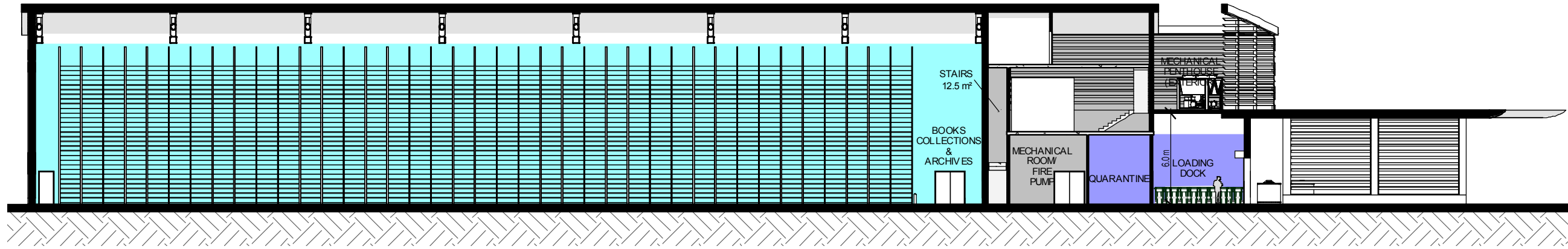

BUILDING SECTION 6

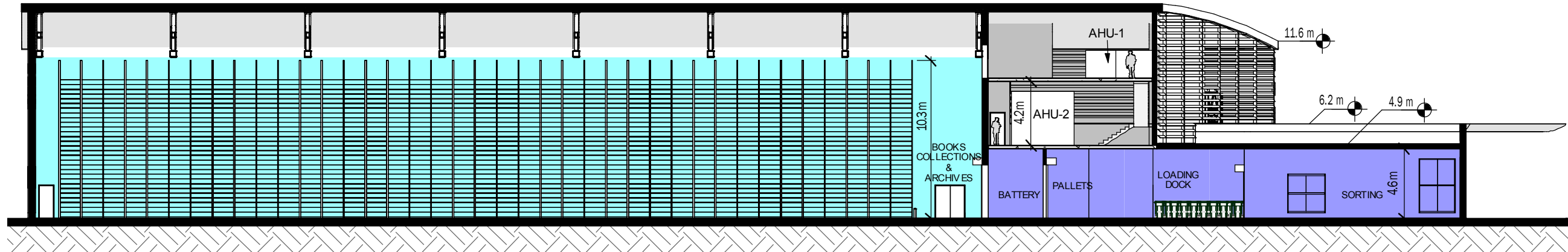

BUILDING SECTION 7

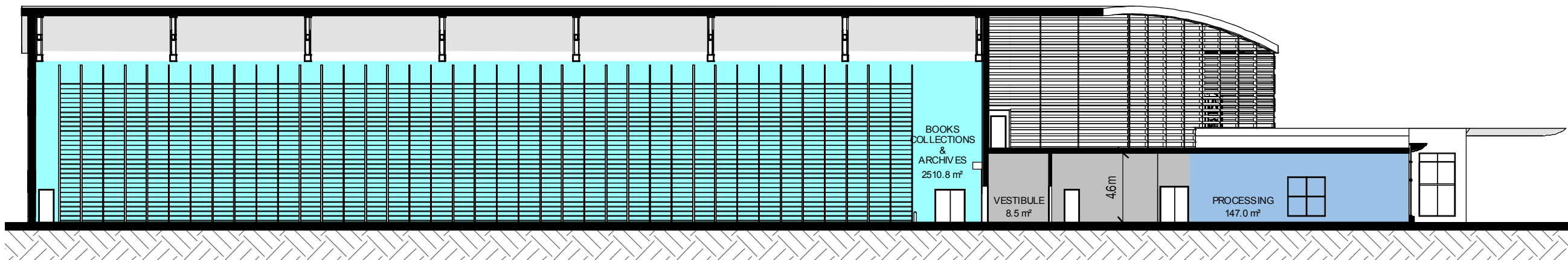

BUILDING SECTION 8

Fire and Life Safety

This code analysis will coordinate both the requirements of the 2014 Alberta Building Code (2014, ABC) and the requirements of the University of Alberta Fire and Life Safety Office. Discussions have begun with Mario Poser, building inspector, for the Inspections Group (the representative Code Authority Having Jurisdiction on behalf of the University) to fully review and vet the assumptions captured within this section. This is an ongoing process that will carry into Design Development, and the Contract Document phases.

Classification and Building Use

The Building Code establishes the basic fire protection requirements based on the area, height and use or function of the building. As height and/or area increases, so does the degree of fire protection. The Code identifies building use categories within designated groupings of occupancy. In mixed use occupancies, if a category is deemed a "major" occupancy and exceeds 10% of a floor area, the more restrictive category will apply.

The RCRF building is basically a Warehouse Type Facility (Group F, Division 2, defined as a medium-hazard industrial occupancy, due to the combustible content of the collections area being greater than 50kg/m²), with the other major occupancy being support offices (Group D, defined as Business and personal services occupancy) the most restrictive occupancy, in this case is the Group F Division 2, and thus will govern.

2014 Alberta Building Code

Article: 3.2.2.77,

For this Group F, Division 2 occupancy, the following requirements prevail:

- The RCRF building is to be sprinklered throughout.
- The building under article 3.2.2.77 cannot be more than four (4) storeys in building height. The RCRF building is 1 storey in height, with a second floor mech. penthouse (not counted as a storey).
- The building area cannot exceed 9,600 square meters, if the building is one storey in height.
- The building is permitted to be of combustible construction or non-combustible construction, used singly or in combination.

- Floor assemblies shall be fire separations with a fire resistance rating not less than 45 minutes. Mechanical penthouse is rated 1 hour – so floor assembly to be one hour.
- Mezzanines shall have, if of combustible construction, a fire resistance rating not less than 45 minutes. No mezzanines at this time
- Load bearing walls, columns and arches supporting a fire separation, shall have a fire resistance rating not less than that required for the fire separation. Any structure supporting the mechanical penthouse is to be rated 1 hour.

3.2.4.1 A Fire Alarm System shall be installed in buildings in which an automatic sprinkler system is installed.

Other fire and sprinkler related code items include:

- Siamese connections for sprinklers
- Standpipe system required by NFPA 13
- Fire Pump
- Emergency power for the fire pump and mechanical systems.

Occupant Load

Due to the specialized nature of the RCRF Building, the maximum number of staff, visitors and students that can be present at any given time in the building anticipated to be no more than 20 persons. This occupant load will be further reviewed to establish any "worse case scenarios" with the University of Alberta, and the authorities having jurisdiction. If 20 persons is deemed acceptable, the occupancy load will be posted in a conspicuous location in each building area as per 3.1.17.1(2).

Fire Separations/sprinklers for specialty rooms/areas

- 3.3.1.21.(3) Janitors' Room - No rating required in a sprinklered building.
- 3.6.2.5 Storage Rooms for combustible refuse - One (1) hour rating.
- Server Rooms - Recommend One (1) hour.
- 3.6.2.1.(1) Mechanical Rooms with fuel fired appliances - One (1) hour rating.
- Staircase to the mechanical room - One (1) hour rating.
- 3.6.2.1.(6) Electrical Rooms (not elect. vault) - One (1) hour rating.
- Loading Dock Canopy, NFPA 13, to be protected with a dry system or glycol sprinkler system.

- Main Entrance Canopy, NFPA 13, to be protected with a dry system or glycol sprinkler system.

Exiting

3.4.3.2 The Minimum Exit Width (for doorways), from a main floor area, shall be determined by multiplying the occupant load by 6.1 mm of exit width per person.

- Table 3.4.3.2.A minimum width of an exit corridor is 1,100mm.
- Doorways are to have a minimum clear width of 850 mm to meet barrier free accessibility.
- 3.4.2.4.(3) Travel Distance: 50m maximum travel distance from any point in a service space. This refers to the mechanical penthouse at the RCRF.
- 3.4.2.6 Location of Exits: 45m maximum travel distance in an F-2, medium hazard industrial occupancy. The F 2 space is the collections (warehouse) area of the RCRF.
- 3.4.2.6 Location of Exits: 40m maximum travel distance in a D, business or personal services occupancy. The D Occupancy is the office area of the RCRF.

Washroom Facilities

The University of Alberta will review their perceived low occupant load with the design team and the authorities having jurisdiction, to determine the number of water closets required. For example, the possible occupant load is no more than 30 persons.

Table 3.7.2.2.B states that for up to 25 persons of each sex, 1 water closet is required.

Two water closets are required for populations of 26 to 50 persons of each sex.

Barrier Free Requirements

The project will be designed and constructed in compliance with the 2014 Alberta Building Code, Section 3.8 Barrier-Free Design including the related provisions for entrances, doorways, barrier-free path of travel and washrooms as well as accessibility signage.

Spatial Separation & Exposure Protection 3.2.3

An existing storage building is located approximately 11 meters north of the proposed RCRF building. A discussion has begun with the authorities having jurisdiction to determine the best course of action to address the exposure of this existing building to the proposed new RCRF. Since the RCRF is imposing upon the existing building it is the RCRF that will need to meet the limiting distance requirements.



Partial Plan - Spatial Separation & Exposure Protection (not to scale)

Limiting Distance calculations for the RCRF Building

The north face of the proposed RCRF building is composed of 7 compartments, they are: (starting from the west)

COLLECTIONS AREA:

- The north face of the Collections Area is 12 m high X 63 m long which equals 756 m² in area, refer to Table 3.2.3.1.E. (example is shown in tables below). The 756 m² relates to the "200 m² or more" line item. Follow the table to find the 11 meter limiting distance from the proposed RCRF to the existing general storage building. The collections area is allowed to have 60% unprotected openings.
- The 60 % unprotected openings is then located in Table 3.2.3.7, which states that a 1 hour rating is required to the north wall to protect the existing general Storage building.
- To achieve the 1 hour rating to the north wall of the Collections area - we discussed with the Inspections Group the possibility of increasing the sprinkler protection to the inside face of the north wall of the Collections area to achieve a one hour rating equivalency. A variance proposal will need to be submitted by the sprinkler consultant. The increase in sprinkler protection is a common approach for achieving a 1 hour rating, and should meet with approval.

STAIRCASE (to the Mechanical Penthouse)

- The north face of the staircase is 6 m high X 1.4 m wide which equals 8.4 m² in area, refer to Table 3.2.3.1.E.
- The 8.4 m² relates to the "10 m²" line item. Follow the table to find the 11 meter limiting distance from the proposed RCRF to the existing general storage building. The staircase is allowed to have over 100% unprotected openings. No rating is required.

MECHANICAL ROOM (main floor)

- The north face of the Mech. Room is 6 m high X 5 m wide which equals 30 m² in area, refer to Table 3.2.3.1.E.
- The 30 m² relates to the "30 m²" line item. Follow the table to find the 11 meter limiting distance from the proposed RCRF to the existing general storage building. The mech. room is allowed to have over 100% unprotected openings. No rating is required to the mechanical room's north wall.

ELECTRICAL ROOM

- The north face of the Elect. Room is 6 m high X 4 m wide which equals 24 m² in area, refer to Table 3.2.3.1.E.
- The 24 m² relates to the "25 m²" line item. Follow the table to find the 11 meter limiting distance from the proposed RCRF to the existing general storage building. The electrical room is allowed to have over 100% unprotected openings. No rating is required to the electrical room's north wall.

LOADING DOCK (interior area)

- The north face of the interior portion of the Loading Dock is 6 m high X 6 m wide which equals 36 m² in area, refer to Table 3.2.3.1.E.
- The 36 m² relates to the "40 m²" line item. Follow the table to find the 11 meter limiting distance from the proposed RCRF to the existing general storage building. The Loading Dock is allowed to have over 100% unprotected openings.

LOADING DOCK (exterior portion)

- The north face of the exterior portion of the Loading Dock is 6 m high X 20.7 m wide which equals 125 m² in area, refer to Table 3.2.3.1.E.
- The 125 m² relates to the "150 m²" line item. Follow the table to find the 11 meter limiting distance from the proposed RCRF to the existing general storage building. The Loading Dock is allowed to have over 72% unprotected openings. A one (1) hour rating is required to the Loading Dock north wall.

MECHANICAL ROOM (upper floor)

- The north face of the Mech. Room is 6 m high X 10.6m wide which equals 64 m² in area, refer to Table 3.2.3.1.E.
- The 64 m² relates to the "80 m²" line item. Follow the table to find the 11 meter limiting distance from the proposed RCRF to the existing general storage building. The upper mechanical room is allowed to have over 100% unprotected openings. No rating is required to the upper mechanical room's north wall.

Table 3.2.3.1.E. Unprotected Opening Limits for a Building or Fire Compartment that is Sprinklered Throughout Forming Part of Article 3.2.3.1.

Exposing Building Face	Area of Unprotected Opening for Groups E and F, Division 1 and 2 Occupancies, %																	
	Limiting Distance, m																	
Max. Area, m ²	0	1.2	1.5	2.0	2.5	3	4	5	6	7	8	9	10	11	12	13	14	15
10	0	8	12	20	34	50	96	100										
15	0	8	10	16	26	36	68	100										
20	0	8	10	14	22	30	54	86	100									
25	0	8	10	14	18	26	44	70	100									
30	0	8	8	12	18	24	40	60	88	100								
40	0	8	8	12	16	20	32	48	68	94	100							
50	0	8	8	10	14	18	28	40	58	76	100							
60	0	8	8	10	12	16	24	36	50	66	86	100						
80	0	8	8	10	12	14	20	30	40	52	66	84	100					
100	0	8	8	8	10	12	18	26	34	44	56	70	84	100				
150	0	8	8	8	10	12	16	20	26	32	40	50	60	72	84	98	100	
200 or more	0	8	8	8	8	10	14	18	22	28	34	42	50	60	68	80	92	100

Table 3.2.3.7. Minimum Construction Requirements for Exposing Building Faces Forming Part of Sentences 3.2.3.7.(1) and (2)

Occupancy Classification of Building or Fire Compartment	Maximum Area of Unprotected Openings Permitted, % of Exposing Building Face Area	Minimum Required Fire-Resistance Rating	Type of Construction Required	Type of Cladding Required
Group A, B, C, D, or Group F, Division 3	0 to 10	1 h	Noncombustible	Noncombustible
	> 10 to 25	1 h	Combustible or Noncombustible	Noncombustible
	> 25 to 50	45 min	Combustible or Noncombustible	Noncombustible
	> 50 to < 100	45 min	Combustible or Noncombustible	Combustible or Noncombustible ⁽¹⁾
Group E, or Group F, Division 1 or 2	0 to 10	2 h	Noncombustible	Noncombustible
	> 10 to 25	2 h	Combustible or Noncombustible	Noncombustible
	> 25 to 50	1 h	Combustible or Noncombustible	Noncombustible
	> 50 to < 100	1 h	Combustible or Noncombustible	Combustible or Noncombustible

3.0 STRUCTURAL DESIGN

Codes and CSA Standards

The structural design shall conform to the following Codes and CSA Standards:

- National Building Code of Canada 2010
- Alberta Building Code 2014
- CSA Standard A23.3-04 Design of Concrete Structures
- CSA Standard S16-09 Design of Steel Structures
- CSA Standard O86-09 Engineering Design in Wood
- CSA Standard S304-14 Design of Masonry Structures
- CSA Standard S136-12 North American Specifications for the Design of cold-Formed Steel Structural Members

Design Loads and Design Considerations

The facility is comprised of two primary structural load conditions. The warehouse space is designed to house a high density storage system for archival material while the front of house area where the material is processed and/or viewed is designed for lighter floor load.

The warehouse storage system is a series of continuous rows of racking approximately 9.1 metres high that forms high bands of load approximately 2.0 metres wide alternating with bands of relatively low floor loads approximately 1.5 metres wide. The facility is sprinklered and, therefore, the supporting floor is designed for a saturated racking load condition. The design load between the racking is designed for the load from the material handling lift.

Seismic loads are rarely governing load criteria in the Edmonton area for low-rise structures. Although it will not govern the building structure, it will impact the racking system which will have a seismic design load component.

The front of house comprises a space to service a number of functions and includes administrative office and library user space, processing, microfilm racking space and mechanical/electrical rooms. The microfilm storage facility will contain racking approximately 14 metres high. The lift will travel between the warehouse and the receiving/loading dock area. Overhead monorails and trolleys will be provided where necessary to facilitate extraction of mechanical equipment components for maintenance operations.

The design loads for the various rooms are identified below:

Environmental Loads:

Snow:	S _s = 1.7 kPa S _r = 0.1 kPa
Wind:	q _{1/50} = 0.45 kPa q _{1/10} = 0.35 kPa
Seismic:	S _a (0.2) = 0.10 S _a (0.5) = 0.06 S _a (1.0) = 0.3 S _a (2.0) = 0.1 PGA = 0.4

Live Loads:

Racking:	70.0 kPa
Drive Aisle:	4.8 kPa
Processing area:	7.2 kPa
Microfilm room:	35.0 kPa
Office	2.4 kPa
Mechanical room:	4.8 kPa
Lift:	to be determined
Axle load (loading dock):	18,000 kg

Dead Loads:

Self-weight of building components.

Foundation System

The south campus site is located in an area containing high plastic soils and a relatively high water table. This poses a significant risk for swelling and shrinkage behaviour in the soil matrix with changes in soil moisture content. The racking system is sensitive to differential movement of the supporting floor system which drives the design towards a structural slab foundation system. The geotechnical report identifies good bearing capacities for end bearing piles at a depth of 12 metres and defines the support for the structural slab system. The foundation system for the warehouse area and the microfilm storage room in the front of house will be structural slab supported on belled piles.

A grade supported slab is proposed for the front of house area excluding the microfilm room. The operation in the office/process space is not as sensitive to differential movement, therefore a 150mm thick concrete grade supported slab on a 300mm granular base is deemed sufficient. Interior columns are supported by piles and the perimeter of the building is supported on a pile and grade beam system. All plumbing lines under this slab and/or near this slab shall have welded seams to preclude the potential for leaks that would cause the soils to swell.

The exterior concrete sidewalks and driveways will be subject to high vertical movement due to seasonal moisture changes in the soil as well as freezing and thawing cycles. This poses risks such as impeded door swings, slab heaving up against exterior cladding and the development of significant slab cracks and tripping hazards. These risks are mitigated by designing all exterior concrete sidewalks and driveways adjacent to the building as a structural slab on piles.

Superstructure Framing

The superstructure shall utilize traditional steel post and beam construction throughout the facility. Structural wood elements may be employed to enhance and serve as architectural features in selected areas. Masonry may be used in selected areas for fire rating, sound attenuation and for elements that work with the building envelope.

The warehouse roof has a barrel vault profile that provides a synergistic benefits for the structural roof framing, the building envelope and the mechanical systems. This profile was chosen to mitigate water ponding on the roof and the need for roof drains that pose a risk of water infiltration into the warehouse space. It also optimizes the weight of the steel roof trusses and develops a depth in the roof trusses with ample space for the large mechanical ductwork to pass through. The depth of truss also allows for a smaller top chord that can be easily rolled to form the barrel profile.

The roof structure over the front of house comprises of steel deck supported on open-web-steel joists on steel beams and columns. The elevated floor system supporting the mechanical rooms shall utilize open-web-steel joists supported on steel beams and columns with concrete floor on steel deck.

Wind forces are resisted with cross bracing throughout the facility. The warehouse has a horizontal truss system along the bottom chords spanning between the west and east walls to transfer wind loads to the vertical cross bracing contained in these walls.

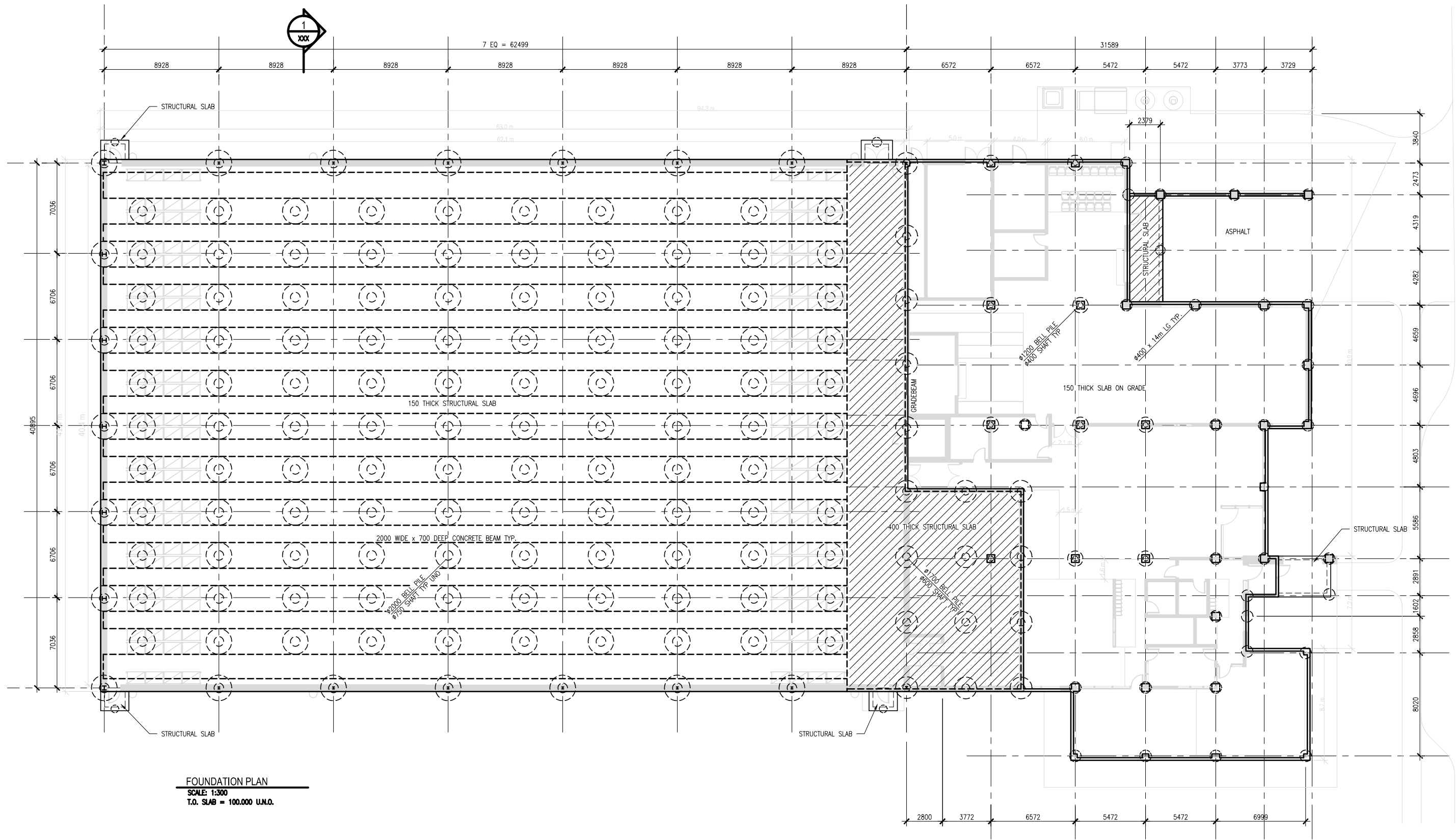

FOUNDATION PLAN
 SCALE: 1:300
 T.O. SLAB = 100.000 U.M.O.

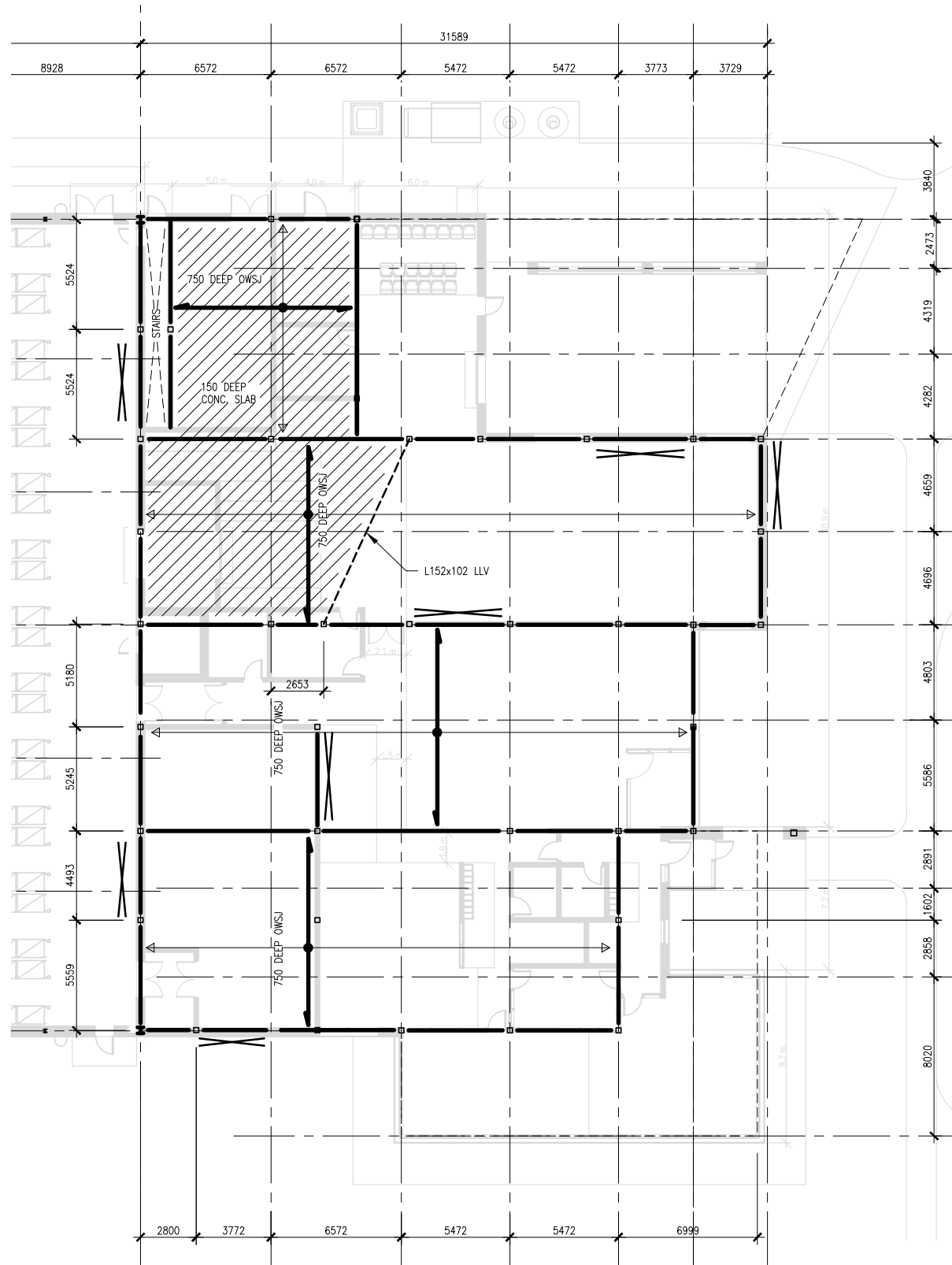

ROOF FRAMING PLAN @ EL. 104.800
SCALE: 1:300

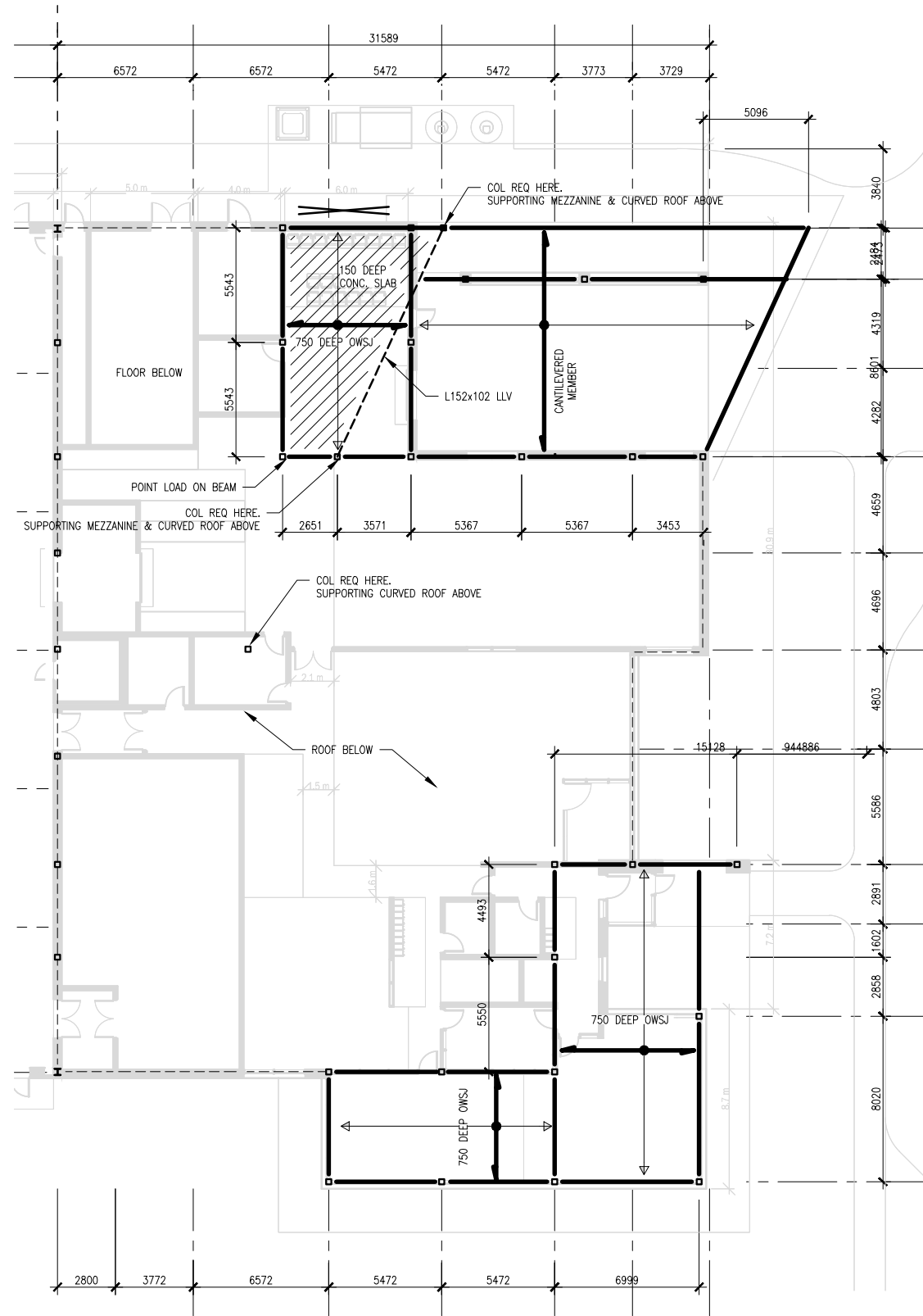

ROOF FRAMING PLAN @ EL. 106.200
SCALE: 1:300

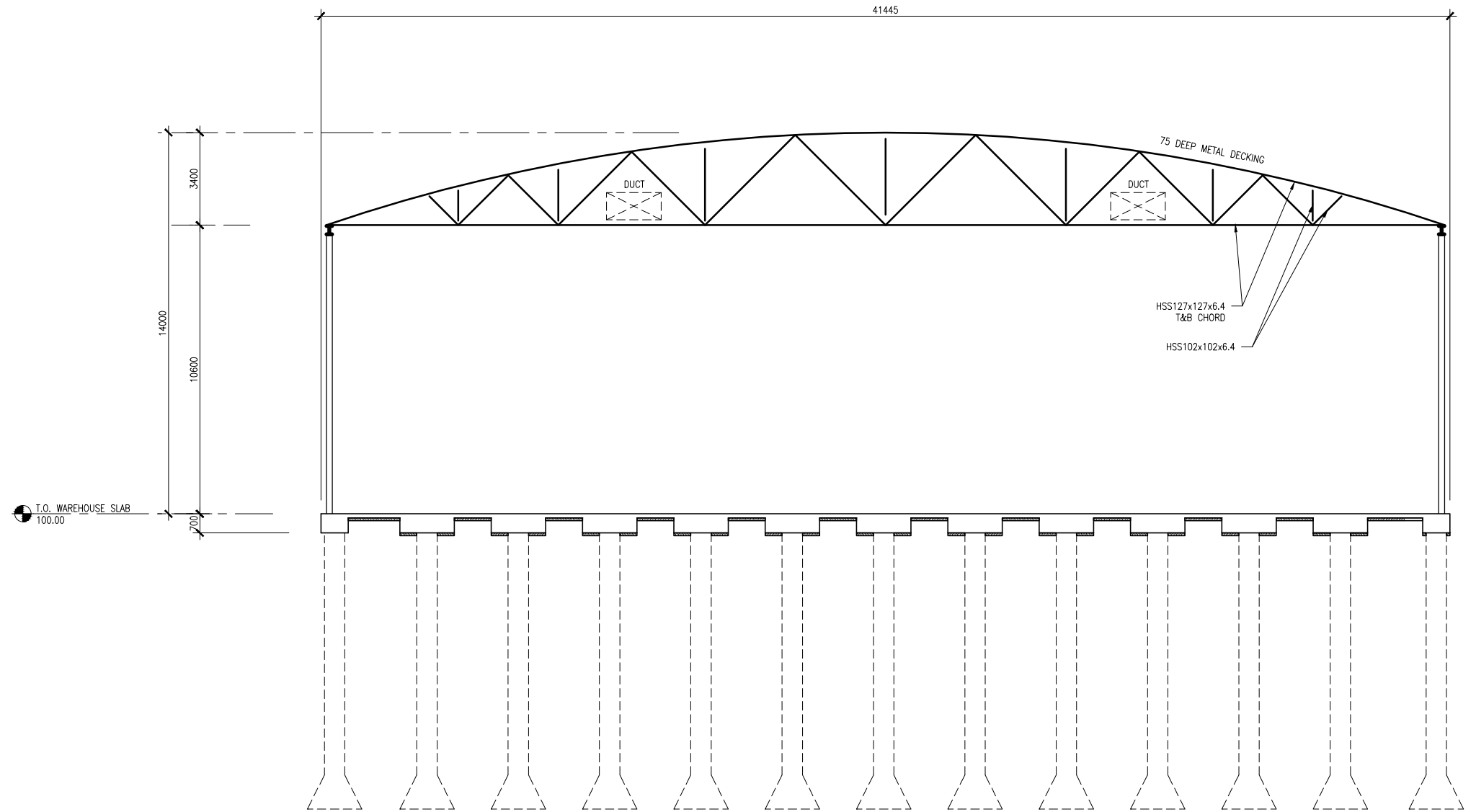

1 SECTION
S-1 SCALE: 1:100

PAGE INTENTIONALLY LEFT BLANK

4.0 MECHANICAL DESIGN

Design Criteria

Requirements from the following Codes and Standards as they relate to the mechanical systems work will be incorporated into the design.

- 2014 Alberta Building Code
- National Energy Code for Buildings
- Alberta Fire Code
- National Plumbing Code
- ASHRAE Guides and Standards
 - ASHRAE 55 – Thermal Environmental Conditions for Human Occupancy
 - ASHRAE 62.1 – Ventilation for Acceptable Indoor Air Quality
 - ASHRAE 90.1 – Energy Standard for Buildings Except Low-Rise Residential Buildings
- NFPA 13 – Standard for the Installation of Sprinkler Systems
- NFPA 10 – Standard for Portable Fire Extinguishers
- NFPA 14 – Standard for the Installation of Standpipe & Hose Systems
 - NFPA 909 – Protection of Cultural Resource Properties – Museums, Libraries, and Places of Worship
- CSA B149.1 – Natural Gas and Propane Installation Code
- CSA B52 – Mechanical Refrigeration Code

Estimates of mechanical system capacities have been based on program needs and areas as well as preliminary architectural layouts. System capacities will be finalized with heating and cooling load calculations through the contract document phase and in conjunction with the details of building envelope construction to be developed by the Architectural Team. Capacity allowances for potential future expansions will not be provided.

Safety: The mechanical systems will support and enhance a safe environment for the building occupants, maintenance personnel and the surrounding community.

Reliability: The mechanical systems will perform their functional purpose under varying operating conditions, both thermal and operational.

Maintenance and Accessibility: the mechanical systems shall be readily accessible for inspection, service or replacement without requiring removal of other systems.

Functional Environment: As much as possible, the mechanical systems shall be simple to understand, simple to operate and simple to maintain.

Human Comfort: The mechanical systems will provide comfort cooling, heating, humidification, and ventilation to maintain appropriate interior conditions for the building occupants.

Flexibility and Expansion: The mechanical systems shall be able to respond to changes in function or in load with only minor modifications.

Sustainable Design: The mechanical systems will minimize the impact on the environment by reducing energy consumption, intelligent selection of materials and careful oversight during construction. Mechanical systems are to be designed to meet Green Globes certification.

Minimize Impact: The new facilities will minimize the negative impact on the existing facilities and site.

Preliminary load calculations and schematic design have been based on the following envelope design conditions:

- Roof – R-30
- Walls – R-20
- Glazing – R-4 low E

Basic design requirements for the facility are:

Space Use	Indoor Design Temp. (°C)	Indoor Relative Humidity	Air Change Rates	Outdoor Design Conditions	Notes
SUMMER					
Reading Room	24	N/A	6	28°C (82°F) DB/19°C (66°F) WB To ASHRAE 2.5% July Design Day	
Collaboration Meeting Room	24	N/A	6		
Office	24	N/A	6		
Archives Processing	24	N/A	6		
Kitchenette/Lockers	24	N/A	6		
Mail/Waiting/Lockers	24	N/A	6		
Processing	24	N/A	6		
Circulation	24	N/A	6		
Storage/supplies	24	N/A	6		
Book Cleaning	24	N/A	6		
Janitor	24	N/A	12		
Battery	24	N/A	6		
Loading Dock	24	N/A	8		
Sorting/Pallets/Recycling Space	24	N/A	12		
Quarantine	24	N/A	4		
Main Floor Mech Room	24	N/A	4		
Electrical Room	24	N/A	4		
Second Floor Mech Room	24	N/A	4		
Microfiche/film cabinet storage	15	35%	6		
Book Collection & Archives	15	35%	8		only calculated to 30' high, rack volumes removed from overall volume (391,230 ft ³)
WINTER					
Reading Room	22	15%	6	-32°C (-26°F) To ASHRAE 1% January Design Day	
Collaboration Meeting Room	22	15%	6		
Office	22	15%	6		
Archives Processing	22	15%	6		
Kitchenette/Lockers	22	15%	6		
Mail/Waiting/Lockers	22	15%	6		
Processing	22	15%	6		
Circulation	22	15%	6		
Storage/supplies	22	15%	6		
Book Cleaning	22	15%	6		
Janitor	22	15%	12		
Battery	22	15%	6		
Loading Dock	22	15%	8		
Sorting/Pallets/Recycling Space	22	15%	12		
Quarantine	22	N/A	4		
Main Floor Mech Room	22	N/A	4		
Electrical Room	22	N/A	4		
Second Floor Mech Room	22	N/A	4		
Microfiche/film cabinet storage	15	35%	6		
Book Collection & Archives	15	35%	8		only calculated to 30' high, rack volumes removed from overall volume (391,230 ft ³)

Site Services

The proposed new facility would be constructed on the University of Alberta South Campus, south of the existing Vehicle Pool Garage and north of the existing Turkey Barn. The proposed utility right of way will be located to the west of the proposed site as noted in the figure to the right.

It is proposed that a new 150 mm diameter sanitary sewer line leave the new building to the south then travel west. This will allow for an opportunity to tie in to the proposed sanitary main in the utility corridor. Exact tie-in location and routing is to be determined by Civil.

All storm sewers will splash to grade. Site grading will drain to the south and dump into a storm water retention pond.

A new 200 mm diameter water service for the building will enter into the north side of the building. Exact tie-in location and routing is to be determined by Civil. A branch from this main will be required to service a new fire hydrant to be located within 45m of the main entrance.

A medium pressure gas line will tie-in to the main located in the service utility corridor. The medium pressure line will travel west to the loading dock area where a gas meter and regulator will be located. The gas pressure will reduce to low pressure before being distributed within the building.

For more details on site services, refer to the Civil section of the schematic design report.

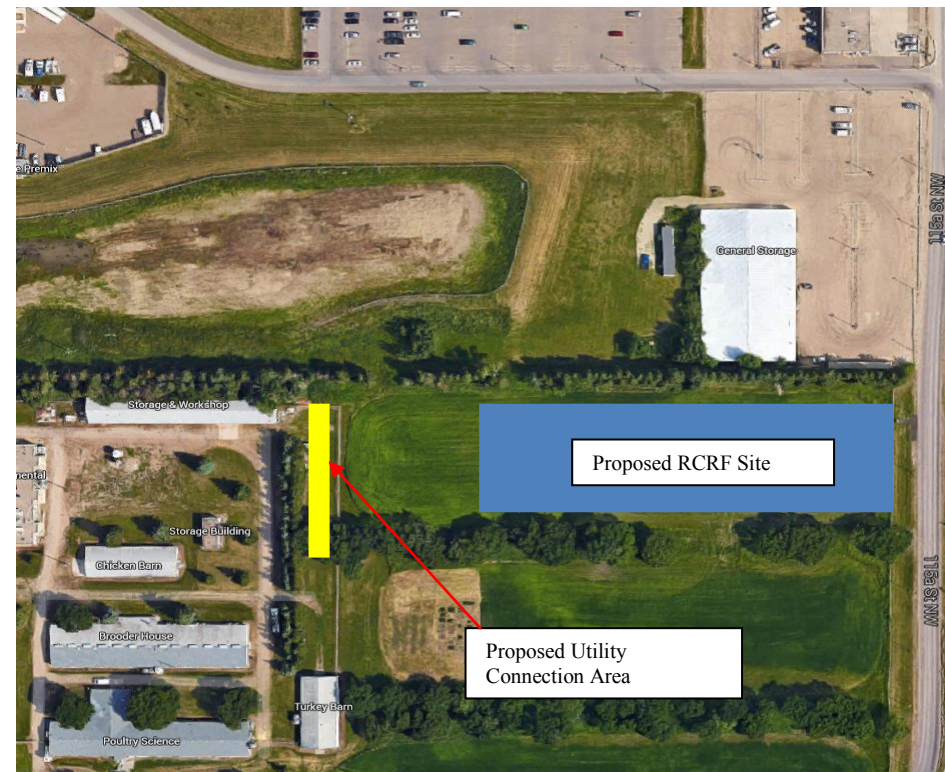

Plumbing

It is proposed that domestic cold water for the building be served from the incoming domestic cold water service to be located in a southwest meter room. A cold water line will be extended to the new penthouse mechanical room to feed a high efficient condensing domestic water heater. A domestic hot water line along with a cold water line will be extended from this mechanical room through the building for distribution to washrooms, janitor rooms and coffee rooms. A domestic hot water recirculation line will be provided with the domestic hot water line. This will enable domestic hot water to be constantly circulated using a DHWR pump so that end-of-line dead legs are minimized. A DHWR pump equipped with an integral variable speed drive will be utilized to vary the speed based on return water temperature. This will assist in minimizing energy usage in low demand periods.

A new 150 mm diameter sanitary sewer line will leave the new building under slab to the south.

Structural has indicated that weeping tile is not required. As a result, no weeping tile pits will be provided.

Piping shall be indicated with system and direction of flow with colour labels. All domestic water piping shall be type 'L' copper, cleaned and flushed of debris before being placed in service. All piping, components and equipment subject to sweating, heat loss or freezing shall be insulated with appropriate thickness of fibreglass insulation with a fire-resistant jacket.

Urinals will be equipped with solar powered (with battery back-up) infrared, low-flow, flush valves. Water closets will be floor mounted tank type, low flow. Lavatories will be equipped with low flow, solar powered (with battery back-up) infrared trim. The water system shall be designed to prevent water hammer conditions by providing air chambers for individual fixtures and shock arrestors for quick closing valves and batteries of fixtures.

A new natural gas line will be extended from the new building entry point. The line will extend through to the new mechanical room to serve the boilers and domestic water heater.

Heating System

The building will be equipped with a standalone full new heating plant installed in the mechanical room.

Heating will be provided through two 1,500 MBH (input) high efficient condensing boilers located in the mechanical room. One boiler is provided for 100% redundancy. Each boiler will be pumped through a primary loop. Two secondary pumps each sized for 100% of the load will circulate through a cascading secondary piping loop which will consist of:

- A perimeter heating & reheat coil loop: This loop will circulate 90°C (195°F) heating water to terminal heating elements to provide perimeter heat in each zone. This loop will also provide heating water to the new terminal reheat coils that will be provided for the new air systems.
- Heating coil glycol heat exchangers: This loop will circulate 73.8°C (165°F) water to two glycol heat exchangers (100% redundant) for the air handling units' preheat and heating coils. On the secondary side of the heat exchanger a 50% propylene glycol solution will be circulated with two pumps (100% redundant) to the air handling unit's preheat and heating coils. A 17°C (30°F) temperature drop will be used for the preheat and heating coils.

Although the boilers will provide 90°C (195°F) heating water in the worst winter situations, the control system will reset the supply water temperature based on outdoor air temperature. This will allow the condensing boilers to provide lower water temperatures and increase the overall heating plant operating efficiencies.

All piping will be routed in a reverse return configuration to aid in balancing the system. Force flows will be provided at any entrances. Unit heaters will be provided in appropriate service spaces as well as the loading dock area.

The collections and archives storage not have any supplementary hydronic heat. The heat for the space will be provided via the space air system.

All pumps will be isolated with neoprene vibration isolators.

Cooling System

A new 75 ton air cooled chiller will be mounted on the roof.

Chilled ethylene glycol will be circulated using two pumps each sized for 100% of the cooling flow requirement. Chilled glycol will be circulated to the cooling coils located in the new air systems. Chilled water pumps will utilize variable speed drives to minimize pumping energy during low flow periods.

Ventilation System Description

The following descriptions apply to the proposed ventilation system design:

Office Air System

The office area shall be served by a single duct variable volume medium velocity air system. The supply air unit will be composed of:

- 30% prefilter (removable during winter months to avoid frost build-up)
- Glycol hot water preheat coil.
- Filtration (85% cartridge filter). Space will also be provided in front of the filters to allow the 30% prefilter to be installed during winter months.
- Chilled glycol cooling coil.
- Heating coil.
- Stainless steel drain pans with minimum 12" P-trap to indirect drain.
- "Fan Wall" plenum fan array with variable frequency high efficiency motors for supply and return air sections.
- Gas fired humidifier.

One supply air unit sized for 7,080 L/s (15,000 cfm) will be provided. Variable air volume boxes with reheat coils will be provided for each zone within the office space. Modulating the reheat coil control valve will control the supply air temperature based on the room thermostat setting.

The office area air system will be designed to ensure a maximum noise criteria (NC) level within the office area of NC-30.

Collections Area Air System

The collections area shall be served by a single constant volume low velocity air system. The supply air unit will be composed of:

- 30% prefilter (removable during winter months to avoid frost build-up)
- Glycol hot water preheat coil.
- Filtration (85% cartridge filter). Space will also be provided in front of the filters to allow the 30% prefilter to be installed during winter months.
- Heating coil.
- Space will be provided for a future carbon filter.
- Chilled glycol cooling coil.
- Stainless steel drain pans with minimum 12" P-trap to indirect drain.
- "Fan Wall" plenum fan array with variable frequency high efficiency motors for both the supply and return air sections.
- Gas fired humidifier

One supply air unit sized for 28,320 L/s (60,000 cfm) will be provided. The unit will only be capable of a minimum amount of outdoor air (2,000 cfm), as the space is minimally occupied. In addition, larger volumes of outdoor air may make it difficult to control the humidity in the collections area. An outdoor air desiccant de-humidifier will be provided to serve the outdoor air for AHU-2. This dehumidifier will be equipped with a bypass for use during low humidity periods.

The collections area air system will be designed to ensure a maximum noise criteria (NC) level within the office area of NC-35.

Supply, exhaust and return air ductwork will be galvanized and constructed to SMACNA Standards.

Fire Protection

The building will be fully sprinklered to NFPA-13 requirements. A sprinkler main line will be extended from the incoming water service in the water meter room. A 100 Hp fire pump (approximately 2,000 USgpm at 60 psi boost) with associated control panel and jockey pump will be installed in this meter room. A fire pump test header will be required to discharge to the exterior. This will require coordination with civil and landscape to ensure that the high flow volumes can be managed.

The Collections Storage area will be equipped with ESFR (Early Suppression Fast Response) sprinkler heads. This eliminates the need for in-rack sprinklers. Zone valves will be provided throughout as required. Sprinklers will be distributed as per NFPA-13 requirements.

Fire extinguisher cabinets will be located throughout in accordance with NFPA-10.

NFPA-13-2002 code states that hose stations are required in all storage occupancies exceeding 12 ft. in storage height. Spacing of hose stations is 100 ft. hose, plus 30 ft. hose stream.

Appropriate drainage for the sprinkler system will be provided for maintenance purposes. This drainage will occur outside the collections space.

A fire department connection will be provided near the main entrance. Civil will provide a new fire hydrant within 45m of the fire department connection as required by code.

Control System

The building control system (BCS) will be a fully BacNet compatible, direct digital control (DDC) system. The system will communicate with the University's central campus control system located in the General Services Building control room. The BCS will be operated from the University's Tridium Niagara Supervisor software interface residing on servers physically located in the RCMS Shop. The server will also communicate with the vendor specific servers located in the RCMS shop.

The system will monitor all mechanical central systems and control the systems to maintain facility conditions to meet design criteria. These conditions will include:

- Supply air temperature, humidity and volume
- Perimeter heating water supply temperature
- Chilled glycol supply temperature
- Space temperature conditions
- Building pressurization
- Domestic water system

The building boilers will be equipped with dedicated manufacturer boiler controls. These will operate and control the boilers in stand-alone fashion. Alarming will be provided to the BCS which will be automatically communicated to the University's operations centre via the Niagara Supervisor. Similarly, the chiller will operate on stand-alone controls with alarming to the operations centre via the BCS and Niagara Supervisor.

Sustainable Design Strategies

The following sustainable design strategies will be implemented in the mechanical design based on good design practice:

- Low flow water closets, lavatories and urinals with infrared sensors are to be installed in all new washrooms
- A high efficiency condensing domestic water heater is to be used to reduce gas consumption
- A DHWR pump equipped with an integral variable speed drive will be utilized to vary the speed based on return water temperature. This will assist in minimizing energy usage in low demand periods.
- Variable speed drives are to be utilized on the supply and exhaust air systems to reduce power consumption
- Variable speed drives are to be utilized on the heating and chilled water systems to reduce power consumption
- High efficiency condensing boilers are to be used to reduce gas consumption
- Low NOx and low CO emissions from the boilers
- Temperature reset control on the perimeter heating water loop to reduce heating water supply temperatures during low demand periods
- Occupancy sensors to shut down air and cooling to specific zones when unoccupied
- Sustainable choice of refrigerants in all cooling equipment
- High efficient magnetic bearing chiller to reduce energy consumption
- Fan Wall fan systems are to be used in the two main air systems to reduce the noise developed, thus reducing the requirements for acoustic silencers. This, in turn, will reduce the static pressure and reduce the horsepower required for the fans.

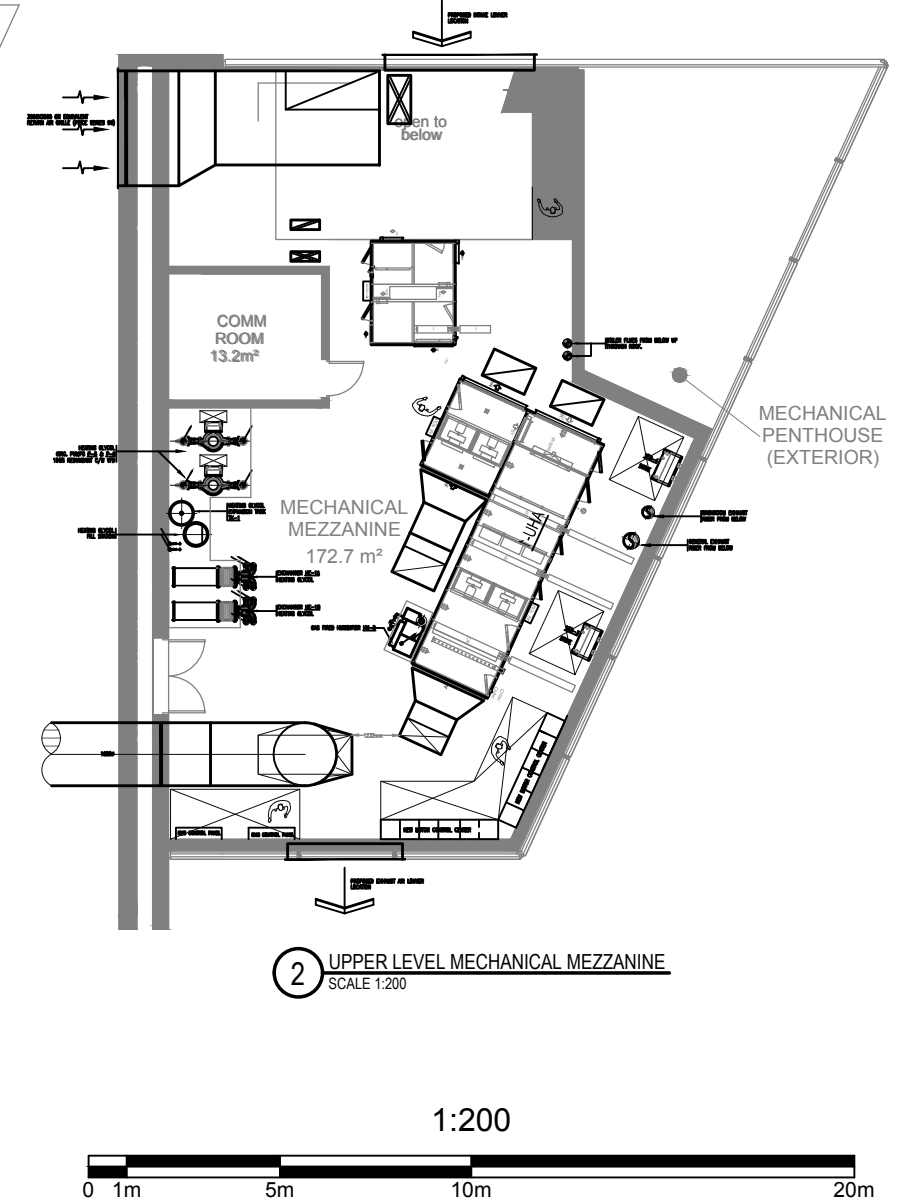
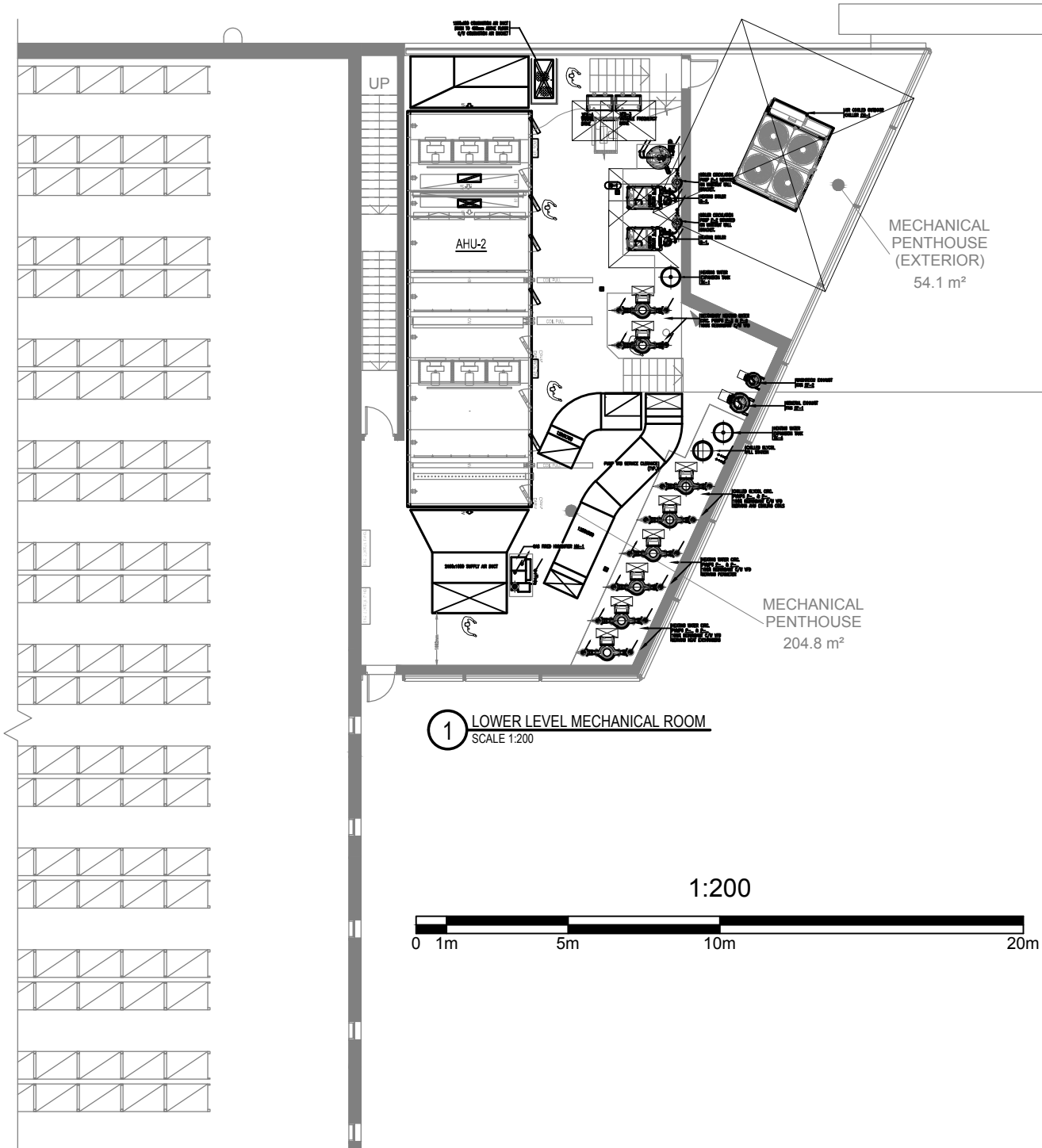

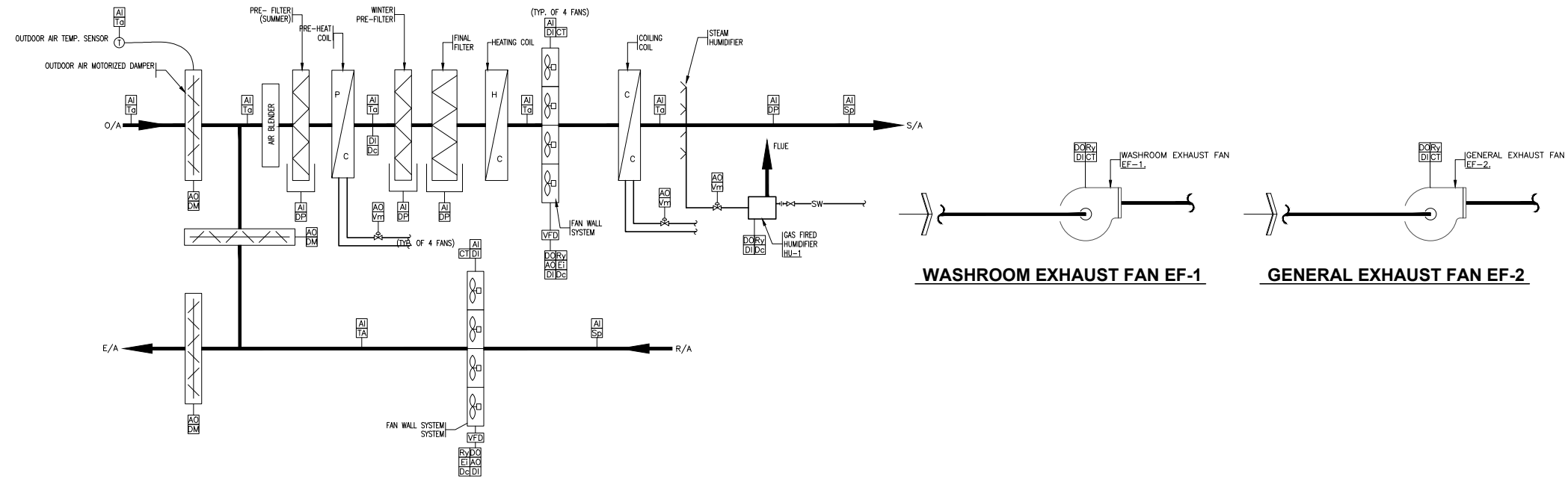

AIR HANDLING UNIT SCHEMATIC - AHU-1

SCALE: N.T.S

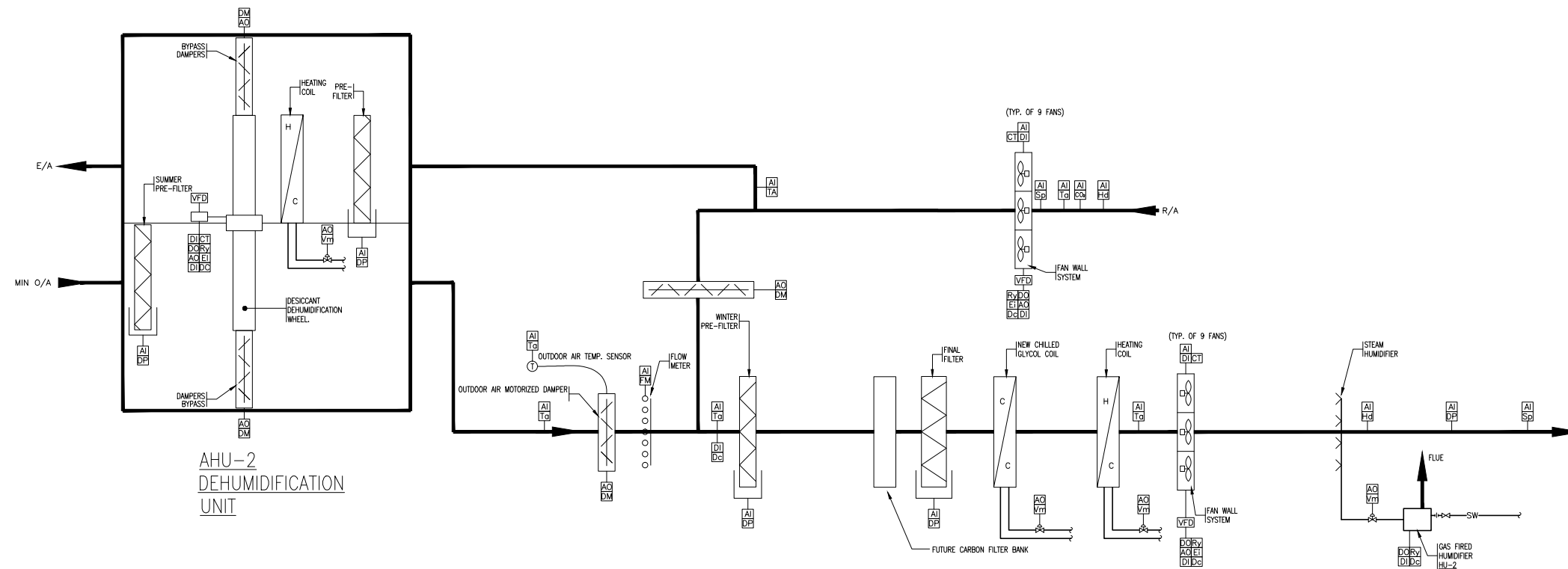

**AHU-2
DEHUMIDIFICATION
UNIT**

AIR HANDLING UNIT SCHEMATIC - AHU-2

SCALE: N.T.S

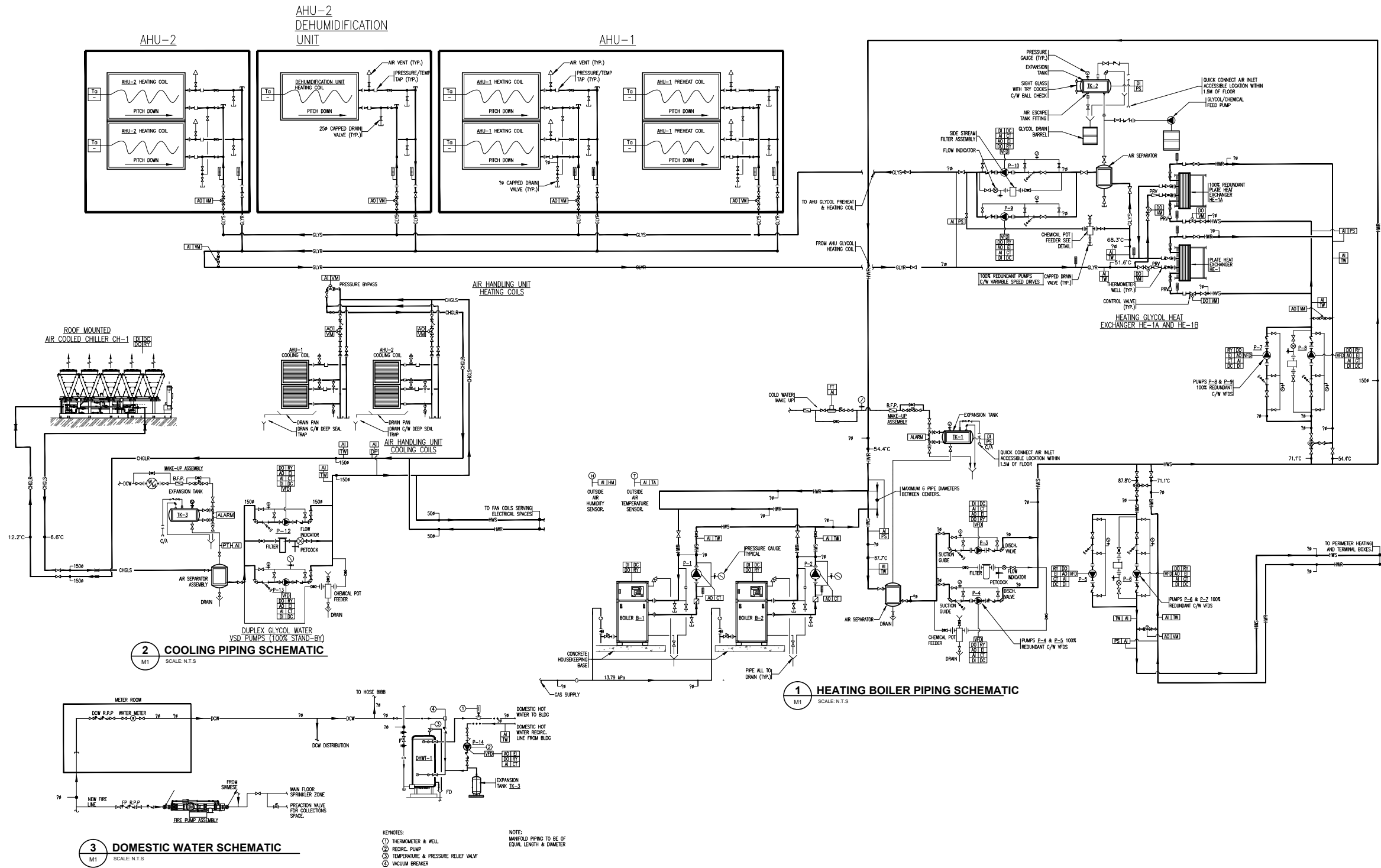

MECHANICAL PIPING SCHEMATICS

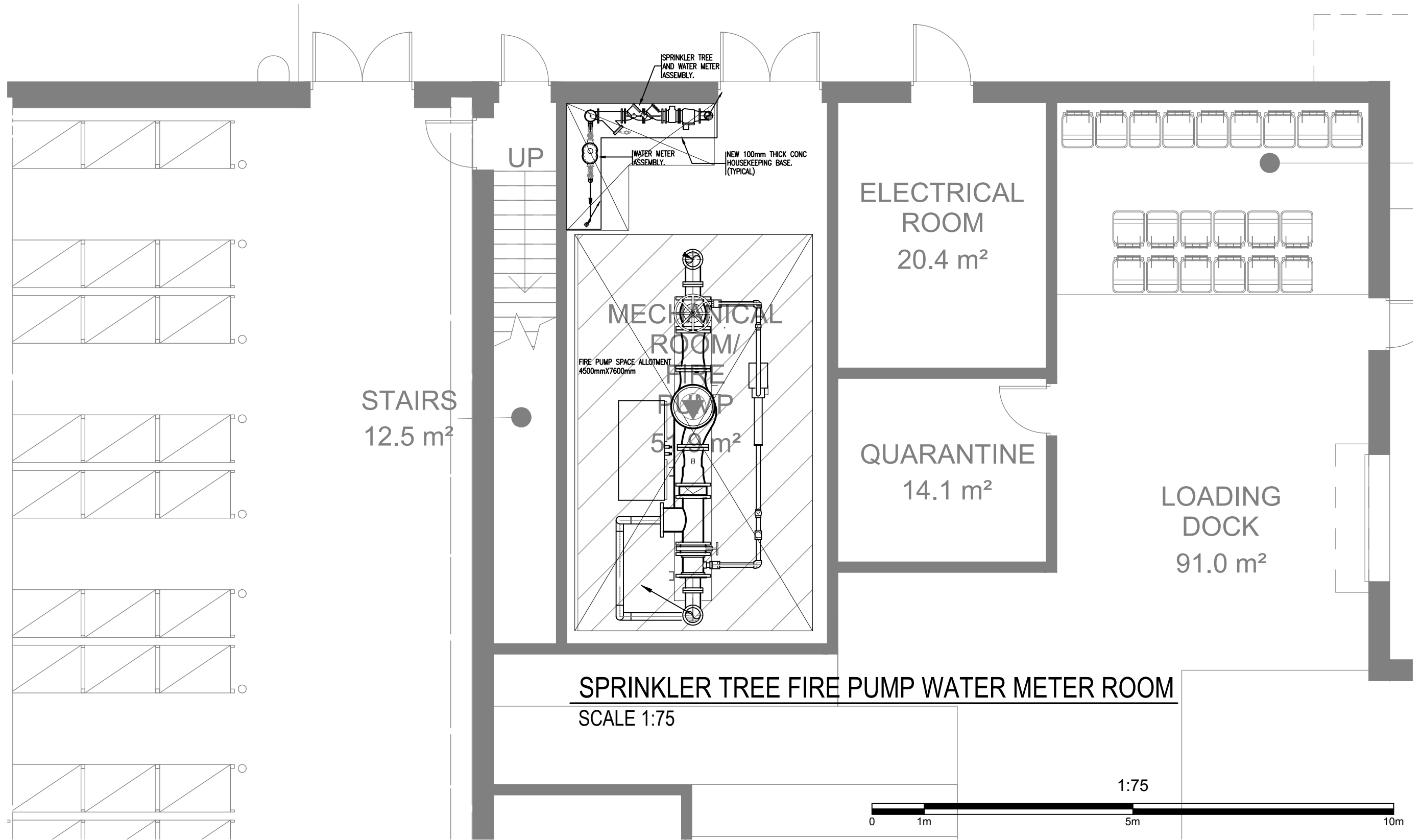

4.0 MECHANICAL

PAGE INTENTIONALLY LEFT BLANK

5.0 ELECTRICAL DESIGN

Introduction

The outline of the electrical systems and facilities contained in this report are to describe the Schematic Design concepts.

This report outlines specific strategies for the electrical systems of the proposed facility and will form the basis for the development of the Design Development phase of the project. A basic outline of the perceived strategies for power distribution, low-tension systems, communication systems and life safety systems for the proposed Research and Collection Resource Facility (RCRF) have been included to summarize discussions and concepts developed to date.

The electrical services proposed for the RCRF are based upon an anticipated gross building area of approximately 40,000 ft².

The electrical design will be based on the following applicable University of Alberta and other applicable standards including:

- University of Alberta, Facilities Management Commissioning Manual.
- University of Alberta, Electrical Design Guidelines.
- University of Alberta, Guidelines for Design and Installation of Street, Sidewalk and Area Lighting – Revised October 2000.
- University of Alberta, Fire Alarm Design Standards, draft copy issued January 2005.
- University of Alberta, Electric Utility Standards, draft issued December 2004.
- ANSI, IEEE, EEMAC Standard for High and Low Voltage Switchgear.
- Latest adopted Canadian Electrical Code – Part I.
- Regulations of the Alberta Electrical Protection Branch – Safety Codes Act.
- Latest Alberta Building Code.
- Latest Alberta Fire Code.
- CSA Standard C282-05 Emergency Electrical Power Supply for Buildings.
- CSA Standard B651-95 Barrier Free Design.
- Latest CSA Fire Alarm Standards and ULC Standards.
- Latest Illuminating Engineering Society of North America (IESNA) Standards.
- IST Telecommunications Design Guidelines, University of Alberta Cabling Standards (latest version to be confirmed by UA).

- University of Alberta, Lighting Design Guidelines and Standards (January 2009, Revision 0.2).

Each system presented in this report will be open to further in-depth review with the user groups and University of Alberta Facility Management group.

Sustainable Design Considerations

The RCRF design will be based upon achieving a Green Globes certification. The rationale for engaging in sustainable design is to create a facility that will contribute to reduced demands on the earth resources. There are three areas that are impacted by engaging Green Globe practices into electrical systems including:

- Energy conservation including controllability of lighting systems,
- Light pollution reduction,
- Low mercury content within lamps.

Sustainability design for the RCRF will be considered based on how Facilities and Operations can maintain these systems and have the budgets to sustain the systems for operations and replacement of systems.

Other sustainable design options to be considered for review are:

- Photovoltaics was considered and discussed not to be pursued at this point.

Energy Conservation:

Electrical energy comprises a small portion of the total energy consumed by a facility but when expressed in actual utility costs, the electrical system consumes approximately 20 – 40% of the total building's energy budget. The following initiatives will be adopted in the design to reduce the building's energy consumption:

- Use the latest illumination technology including LED lighting, T8 and T5HO fluorescent lamps and very high efficiency luminaires wherever possible and justified by application.
- The Minimum Energy Performance prerequisite in Green Globes is intended to comply with the minimum level of energy efficiency as specified in ASHRAE / IESNA 90.1. The basic requirement to improve energy performance is to include some means of efficient controls technologies. It

is proposed to provide this means of control by providing indirect lighting control through the use of occupancy sensors in the warehouse and direct control through local switching in the office and public spaces.

- Other measures that will be provided to further improve the baseline energy performance are the use of occupancy sensors, daylight harvesting sensors, photocells and improved local controls including those employing a relay based lighting system. An interface to the University's building automation system will optimize the use of lighting and ventilation systems when a space is occupied and reduced usage when spaces are not occupied.
- Engineered lighting systems to provide appropriate lighting levels that are safe and effective. Lighting will comply with prescribed guidelines rather than using light levels that are on the high end of the IESNA (Illuminating Engineering Society of North America) standard. It is proposed that lower ambient lighting levels be employed in offices and public spaces.

The following non-Green Globes energy efficient design parameters will be considered:

- Use of time delay relays for larger motor loads to help reduce peak power demand.
- Power distribution centres will be located as close as possible to their connected loads, thereby minimizing the length of branch circuit wiring which in turn will improve the voltage regulation.
- Designated equipment to have "manual-off-automatic" controls such that they can be run in manual mode or automatically through the building management system.
- Use of copper-wound versus aluminum-wound transformers. Copper-wound transformers are more efficient than aluminum-wound transformers and consume less energy.
- The design will favor the use of environmentally friendly components such as LED lamps and fluorescent lamps with low mercury content.

Power Distribution

Power Distribution – Approach:

The design approach for this facility is to provide a pad-mounted utility transformer with 13.8 kV on the primary and 600 V on the secondary provided by the U of A.

Power Distribution System Design:

The total connected load for RCRF is estimated at approximately 450kW based on a building size of approximately 40,000 ft². A 400A, 347/600V service is estimated but demand loads will need to be further reviewed with UofA Electrical Utilities. The design provides for a minimum of 25% reserve capacity and will not be designed to allow for any future expansion to the building.

Main Electrical Room:

Will be located on the main floor with direct access via exterior door. The main electrical room will house a 347/600V and 120/208V distribution as well as the ATS for the emergency generator.

Electrical Distribution Equipment:

Mechanical Penthouse – to house 600V Motor control Centre (MCC) as well as 600V and 120/208V distribution.

The RCRF service entrance switchgear will be metal-enclosed indoor rated 600V, with withdrawable type power-air circuit breakers complete with programmable protective relays.

The standard operating, distribution and utilization voltages for RCRF will be 600 V, 3-phase, 3-wire and 120/208 V, 3-phase, 4-wire. In general, feeders that supply 208 V distribution transformers, large mechanical motor loads, and with high amperage electrical loads will be supplied at 600 V.

All other loads will be supplied from 120/208 V, 3-phase, 4-wire electrical distribution systems. A sufficient number of 120/208 V panelboards will be located throughout the facility to maintain required voltage levels. The panelboards will have a minimum of 25% spare for future use.

Emergency Power Distribution:

A 225kW emergency generator will be provided to feed the fire pump and life safety systems. A diesel generator will be provided complete with a 24 hour sub-base fuel tank and sound attenuated enclosure.

Mechanical Systems:

All motors 0.25 kW and smaller will be single-phase 120 V and all motors at 0.37 kW and larger should be 600 V, 3-phase. The supply and installation of all motor protection switches, starters and disconnect switches for mechanical equipment will be provided by the electrical contractor. Time delay relays will be provided for all motors 18.65 kW (25 hp) and larger. A disconnect switch will be provided for and at each motor. Motor control centres of the grouped design should be utilized where large quantities of mechanical equipment are located such as at wet mechanical rooms, penthouses, etc. in order to reduce capital costs of equipment and allow more effective use of mechanical room space. VFD controlled motor loads will be fed from Distribution Centres (CDP) rather than Motor Control Centres. Energy consumption of all HVAC loads is required to be measured for the Green Globes measurement and verification credit.

The variable speed drive starters (VFDs) and electrical equipment to be grouped away from wet, dusty or hot areas.

Grounding and Bonding:

Grounding system will be designed to provide a low impedance path for ground fault currents to flow. A further review of the soils conditions will be completed during the next phase of design.

Each of the electrical rooms will have a grounding bus connected to the nearest substation, which is turn will be connected to the ground grid. All non-current-carrying metal parts of equipment in the electrical rooms will be bonded to ground per Canadian Electrical Code. This will include all metal raceways, equipment enclosures, metal structures, low tension systems and miscellaneous metal systems. A bonding conductor will be provided in each conduit.

General Wiring:

All wiring will be installed in conduit. Copper wiring is recommended to be used in the facility except for feeders/ conductors 150 A and larger where aluminum wiring will be used. It is recommended that conduits not be installed in the concrete slabs. This will provide greater flexibility for future renovations and additions.

The use of cable tray systems and other wiring methods increasing the future expansion and modification options for the various systems will be further investigated during the Design Development process.

Cabling for life safety systems such as elevators, fire alarm systems, etc. will be minimum one-hour fire rated. Inverter grade cables will be used from VFD's to the motors when they are separated by more than 10 m of cable length from the VFD's.

Lighting

The lighting system will be designed to provide for the functional requirements of the installation. Established standards and parameters for an educational facility will be used for the design. The Illuminating Engineering Society of North America (IESNA) standards and the University of Alberta lighting design guide will be the key references. The objective to achieve Green Globes certification will at times result in variances being made to these key references. Energy consumption considerations and lighting levels will be carefully weighed with the benefits of achieving a Green Globes certification.

The lighting system for the RCRF will be designed with functionality with the users for the various tasks that happen in both the storage facility and in the office while reducing potential degradation to the collection materials.

LED lighting was considered to be used for the facility and specifically for the storage area but after further discussions with the UofA and User Group fluorescent lighting was deemed to be more feasible. It was determined through these discussions that since the lighting within the storage space would not be 'on' for very long periods of time, the hours of operation for these fixtures would be drastically reduced; resulting in lower life cycle costs and paying a premium for LED lighting would not be feasible.

Lighting levels within the building will target the following values:

- General Office areas – 300 lux
- Work spaces – 450 lux
- Storage area – 250 lux

Some of the lighting concepts being considered are:

- Wall washing luminaires on all exterior perimeter elevations.
- Soffit lighting along the east façade, reading room canopy and loading bay canopy.
- Soffit lighting at the main east entrance.
- Vertical entry plinth lighting.
- Site lighting is currently not being considered but can be further reviewed during the next phase in conjunction with UofA Utilities.

Lighting Control System:

All building lighting will be controlled to decrease energy use, allow flexibility and to meet the requirements of the University of Alberta and applicable standards. The lighting control system will be a relay based system that will allow interface with the Building Automation System. Controls will include:

- Daylight sensors for perimeter spaces, with dimming control for luminaires in these areas.
- Occupancy sensors will be provided in the offices and warehouse storage space.
- Manual switches (digital) will be provided in all rooms for local control.

The control system will be standard relay based to meet the requirements of the Green Globes program and intended to only increase user comfort and ease of maintenance but to reduce the energy usage in the building.

Certain luminaires in public spaces and paths of egress will be connected to the emergency power system to provide the code required egress lighting.

Fire Alarm System

The fire alarm system will be a single-stage, annunciated, class A-wired and electrically supervised system. Zoning of the fire alarm system will be based on smoke zone subdivision. System devices will be of the addressable type and will consist of manual pull station, products-of-combustion detectors, thermal detectors and sprinkler flow valves.

A two-stage system can be considered but further review will be required during the next phase of design.

Fire alarm sounding devices will be of the audible and visual (strobe) type in compliance with the latest Alberta Barrier-Free Code requirements. The building is to be equipped with fire fighters telephone handsets.

Beam detection will be utilized for the warehouse area for coverage and allow for ease of maintenance.

The fire alarm system will also be interconnected into the campus wide FM Net system and Mass Notification System.

Low Tension Systems

This section of the report discusses the various low tension and security systems that are envisioned to be installed in the RCRF. Each system has been identified in an effort to capture the perceived requirement for the RCRF.

Access Control System:

The team will be engaged in further discussions with the University of Alberta user groups and facility management staff to define which doors requires card access.

Further review will be required in conjunction with a CPTED review provided by the UofA.

At the present, the project will allow for the installation of conduit and cabling system complete with all necessary power supplies, end devices and architectural electrified hardware devices for four (4) doors. Access control has been discussed for the staff entry only.

Security Television System:

Security television design requires further discussion with the users and architect; however, it is envisioned the public reading space, loading dock and select portions of the exterior are to have cameras.

Emergency Blue Phone System:

Blue phones to be reviewed by the UofA and provided as required to meet the overall campus requirements. At this time there is no provision for a blue phone system.

Clock System:

GPS wireless clock system will NOT be provided throughout the facility.

Public Address System:

A building wide public address system will NOT be provided. Fire alarm system will be used for mass notification.

Mass Notification System:

A Mass Notification system will be deployed throughout the facility and will be fully integrated with the Campus wide system connected through the fire alarm system interface. The system will incorporate text to speech functionality through the fire alarm system speakers. Marque messaging boards and Alertus panels will be provided throughout and will require further coordination with the University for locations.

Communication Infrastructure

Main Communication Room – Service Entrance:

Main Communication room will be located in Mechanical Penthouse area to house telephone/data, demark point, fire alarm and security head end systems.

The RCRF User IT group will work closely w the design team and IST to determine the facility requirements. It is understood that the main server will be housed within this facility. Final details to be determined during the next phase of design.

Three sets of four inch conduits will be provided from the existing fiber pedestal along the east side of the building. The existing conduits currently running across the site will be abandoned.

A further review will be required during the next phase of design with the UofA to determine if there are other options for providing incoming services from other locations along the property line.

Structured Cabling Pathways:

Communications cabling will be installed in conduits, stubbed up to the closest cable tray and run to the designated Communications Room.

Cable trays will be 105mm by 300mm. All conduits for communication systems shall be EMT (electrical metallic tubing). Flex conduit is not permitted. Minimum conduit size for voice/data outlets will be 27 mm. Maximum fill ratio is 40% per the Telecommunication Industry Association standards. Office areas will be an additional set of two (2) conduits to be located on an opposite wall complete with pull strings to allow growth and/or support office rearrangements. Design will provide for one power receptacle (2 per duplex outlet) per data port.

Routing of horizontal structured cabling will be accomplished by utilizing the main cable trays within the corridors, and providing conduit stubs into the ceiling space from voice/data outlets.

Data and Voice Cabling – Structured Cabling:

A power duplex outlet will be placed in close proximity to all voice and data drop outlets including future data/voice drop locations.

- **Data Network Architecture:** using standard Ethernet design concepts and protocols, this system will be built on a logical bus and centralized physical star topology using vertical and horizontal cabling and localized switching. The horizontal segments will be built using structured cabling solutions with home runs from the outlet jack back to rack mounted patch panels inside the closest Communications Room. Vertical segments will provide connections between the Communications Rooms and a centralized location such as the Main Communication room. Fiber connections will be made to the campus wide area network(s).

Data Outlets:

Copper: Certified Category 6 unshielded twisted pair structured data/voice cable will be utilized for horizontal distribution. The maximum cable run distance is 90 m between terminating devices (additional 10 m allowance for interconnecting patch cabling).

Fibre: Full duplex 50/125 micron optimized multimode fiber optic cable is to be provided if user identifies locations for high speed / bandwidth applications. Cable runs will be dependent upon type of cable selected but typical multimode is 300 m and single-mode 1000 m' however, the maximum horizontal run shall remain 90 m per the Telecommunication Industry Association standard.

Specific requests for an unbroken fiber connection between two (2) points longer than 90 m that also require spanning floors will be considered on a case-by-case base nature. It is likely that this fiber will be physically separated or uniquely marked to avoid confusion with other riser fibers.

Voice:

Voice communication will consist of Voice over Internet Protocol (VoIP) for standard voice and data communication.

VoIP Network Architecture: The design will consist of a certified category 6 UTP cable between each outlet jack to a rack inside the Communication Rooms.

At the rack, the cabling will be translated into a fiber connection back to the Main Communication Room where it will connect to a VoIP Call Manager.

The telephone handsets and the telephone switch will be supplied, installed and programmed by the University of Alberta as required.

Wireless Local Area Network:

With the exception of areas sensitive to radio frequency interference (RFI), this facility will contain a complete 802.11abg enterprise designed wireless infrastructure consisting of access points, network switches, servers, wireless local area network (WLAN) controllers and the necessary cabling infrastructure as required throughout all general areas as well as the mechanical room.

It is our understanding that the University of Alberta has conducted a review of existing WLAN technologies for capable enterprise wide wireless wide area network (WWAN) solutions and has decided on a Cisco system provider. The RCRF wireless solution will be an extension of the campus wireless system. It is also anticipated that there will be wireless hot-spots offered for the general public.

Unlike data that can be resent if lost or damaged, voice communication is highly susceptible to drop out. Data communication success over a WLAN depends mostly on WLAN localized bandwidth and security.

Combining the needs of voice and data will require an access point distribution with 20% overlap with minimum cell edge signal strength shall of -70 dB and a minimum Signal to Noise Ratio of 25 dB and numbers sufficient to maintain high speed communication.

The density of access points in most areas will be spaced a maximum of 10 to 20m based on the level of usage required. Further review will be required with IST and RCRF's IT group.

Commissioning and Testing

In a project of this nature it is imperative that the commissioning and testing of major electrical equipment and systems be undertaken by a commissioning and testing agency. This work will include necessary verification and start-up procedures. Operation and Maintenance manuals incorporating copies of shop drawings, complete schematic diagrams, recommended maintenance schedules, and logs, system operation write-ups, test results, and safety procedures will form part of the electrical contractor's scope of work.

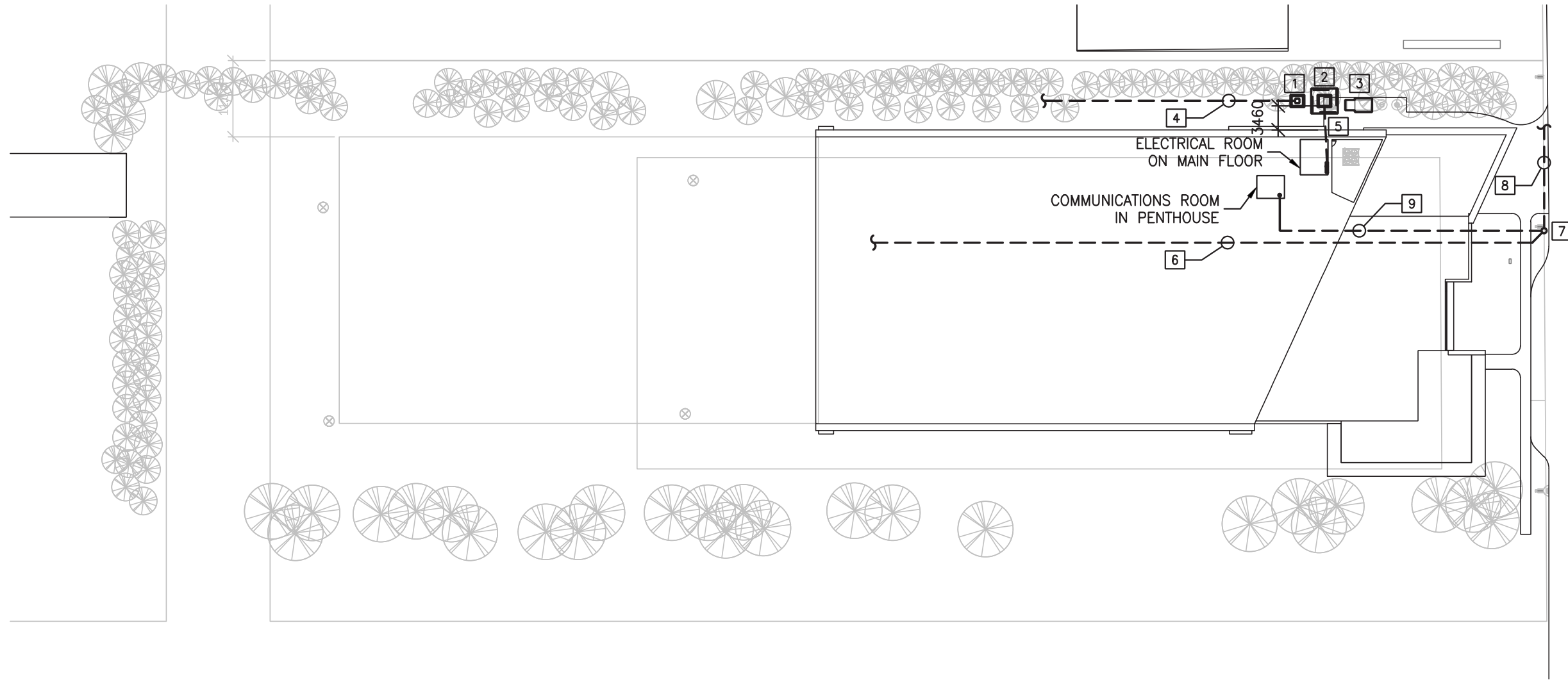

- KEYNOTES:**
- 1 NEW PADMOUNT METERING CUBICLE BY U of A.
 - 2 NEW 500kVA 347/600V PADMOUNT TRANSFORMER BY U of A.
 - 3 NEW GENERATOR c/w 24 HOUR SUB BASE FUEL TANK AND SOUND ATTENUATED ENCLOSURE.
 - 4 INCOMING PRIMARY CONDUIT BY U of A FROM UTILITY CORRIDOR/ROW.
 - 5 SECONDARY CONDUIT FROM TRANSFORMER TO ELECTRICAL ROOM.
 - 6 EXISTING 3-103mm FIBRE CONDUITS TO BE ABANDONED.
 - 7 APPROXIMATE LOCATION OF EXISTING FIBRE MANHOLE.
 - 8 EXISTING 3-103mm CONDUITS ROUTED TO FIBER HUB ROOM.
 - 9 PROPOSED 3-103mm CONDUITS FOR FIBER FROM EXISTING MANHOLE TO COMMUNICATIONS ROOM IN PENTHOUSE.

ELECTRICAL SITE PLAN

SCALE: 1:700

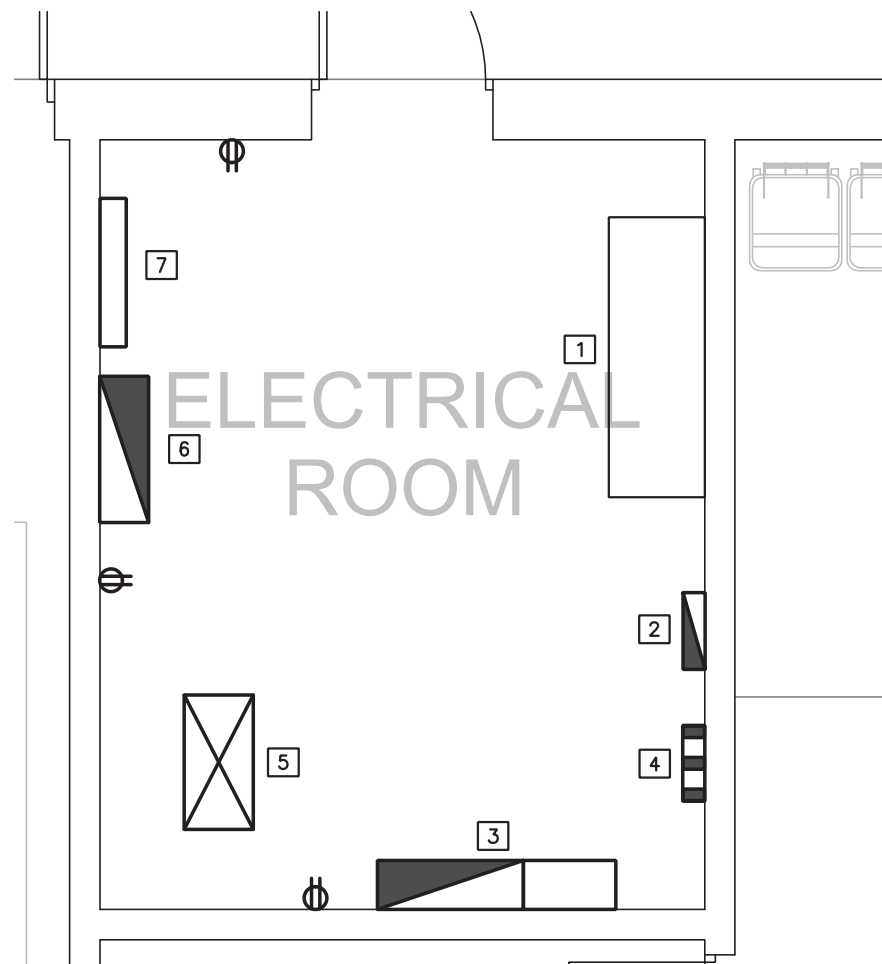

KEYNOTES:

- 1 BYPASS ISOLATION AUTOMATIC TRANSFER SWITCH.
- 2 347/600V EMERGENCY PANEL.
- 3 800A, 347/600V NEW RATED SERVICE ENTRY SWITCHGEAR.
- 4 GROUND BUS. COORDINATE EXACT LOCATION PRIOR TO ROUGH-IN.
- 5 600-120/208V FLOOR MOUNTED TRANSFORMER 'T-1'.
- 6 400A, 120/208V PANEL.
- 7 SPACE FOR FUTURE PANELS.

ENLARGED ELECTRICAL ROOM LAYOUT
SCALE: 1:50

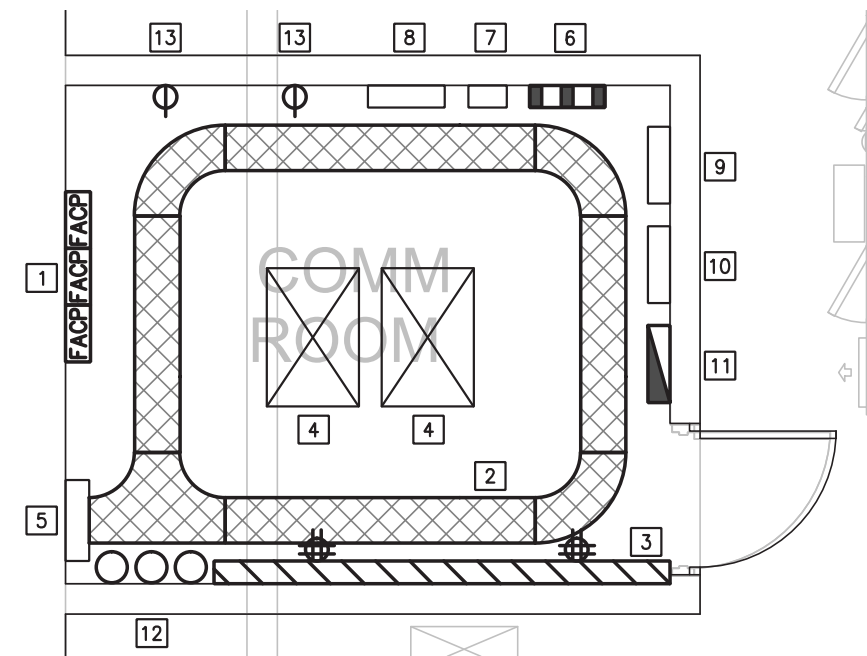

KEYNOTES:

- 1 FIRE ALARM CONTROL PANEL.
- 2 CABLE TRAY.
- 3 MAIN TELEPHONE BACKBOARD.
- 4 4 POST DATA RACK c/w FMNET SWITCH.
- 5 CABLE TRAY PENETRATION THROUGH FLOOR.
- 6 GROUND BUS.
- 7 ALERTUS BEACON.
- 8 TTS FIRE PANEL INTERFACE.
- 9 SECURITY POWER SUPPLIES.
- 10 SECURITY PANEL.
- 11 225A, 120/208V PANEL.
- 12 3-103mmC COMMUNICATIONS RISERS.
- 13 208V DUPLEX RECEPTACLE.

ENLARGED COMMUNICATIONS ROOM LAYOUT
SCALE: 1:50

LEGEND OF SYMBOLS	
SYSTEMS	
▽	DATA OUTLET
∇	TELEVISION OUTLET
FIRE ALARM	
⊗	SMOKE DETECTOR
⊗ ^F	FIXED TEMPERATURE HEAT DETECTOR (58°C)
⊗ ^{SA}	DUCT SMOKE DETECTOR (ADDRESSABLE) – 'SA' DENOTES SUPPLY AIR, 'RA' DENOTES RETURN AIR
⊗ ^B	BEAM DETECTOR
■	FIRE ALARM MANUAL PULL STATION

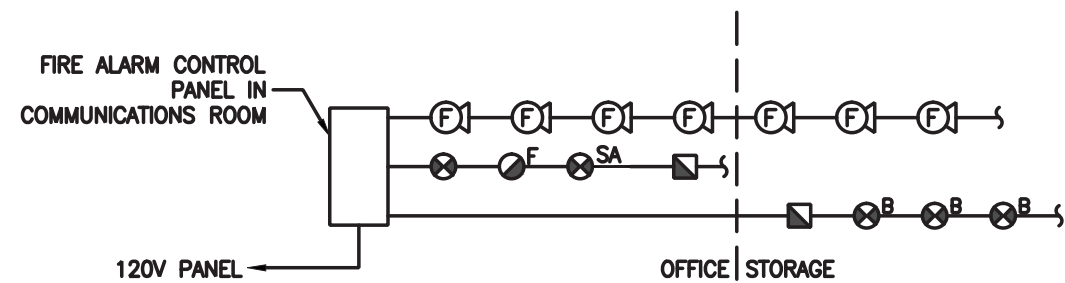

FIRE ALARM RISER DIAGRAM

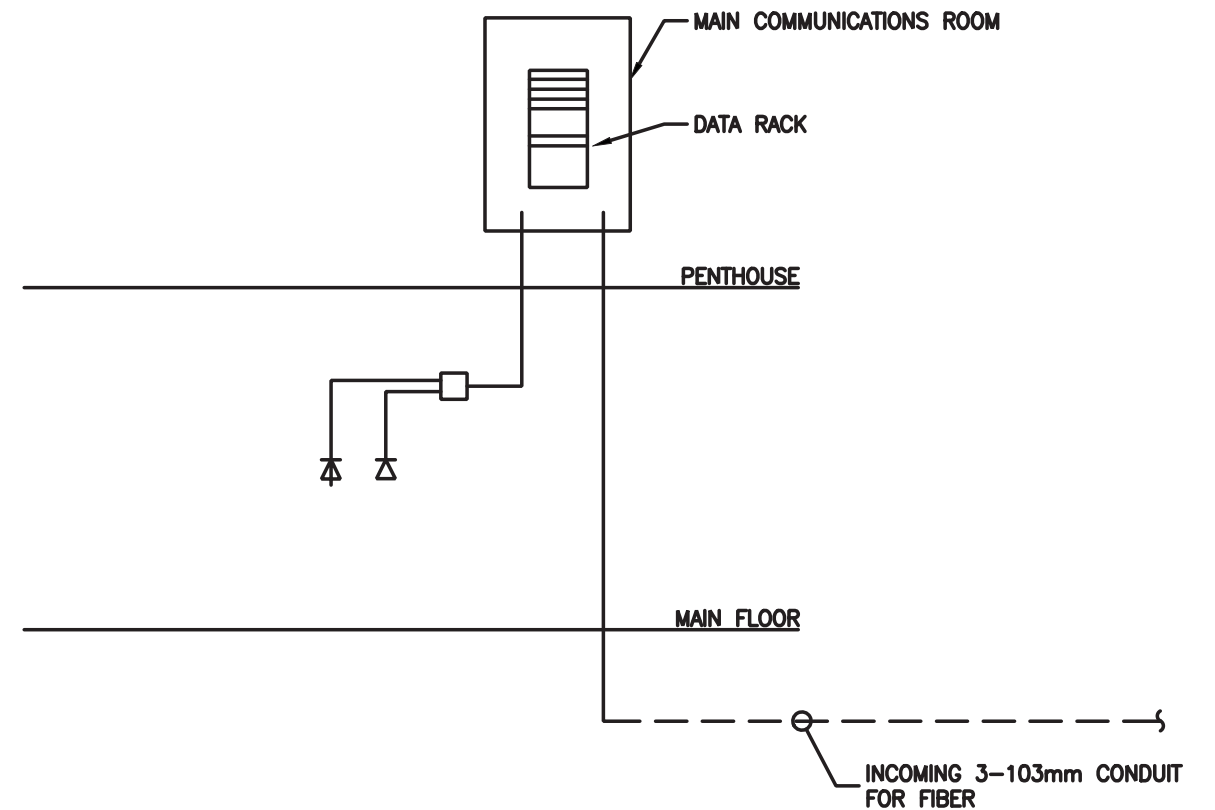

COMMUNICATION RISER DIAGRAM

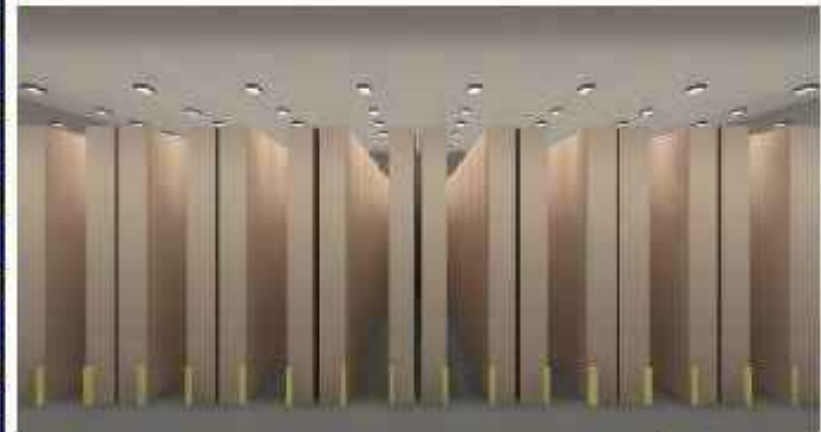
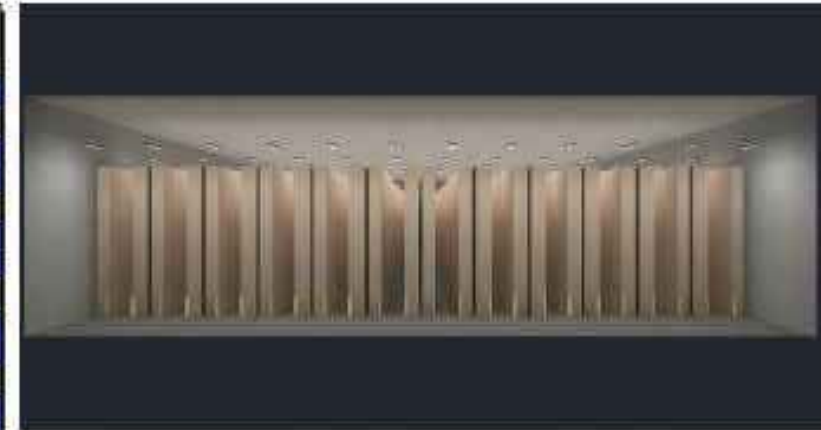
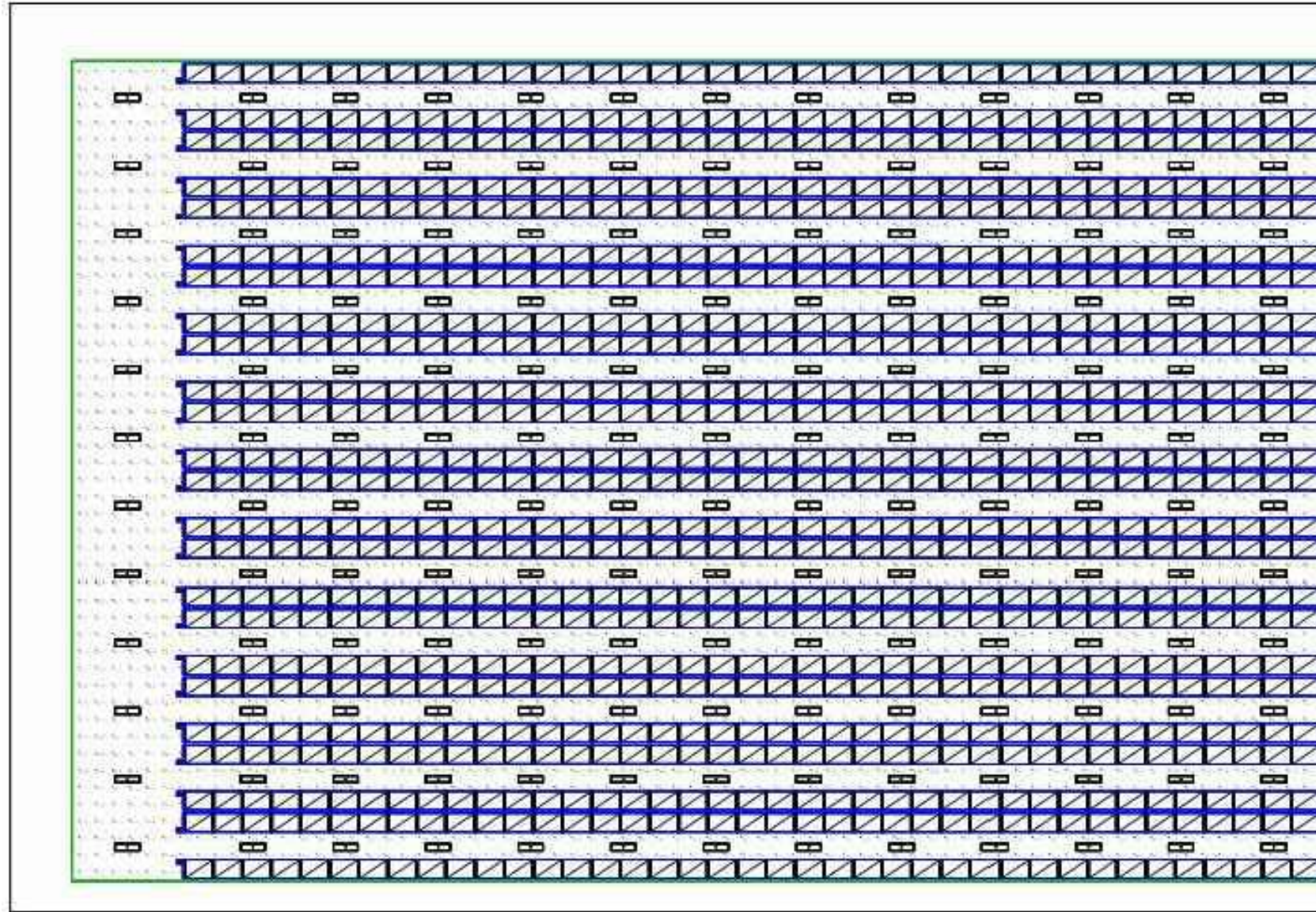

Calculation Summary							
Label	CalcType	Units	Avg	Max	Min	Avg/Min	Max/Min
Warehouse Workplane	Illuminance	Fc	28.45	46.5	13.6	2.09	3.42

Luminaire Schedule				
Symbol	Qty	Label	LLF	Description
•	156	4 Lamp T5HO	0.950	FBF454HO-UNV-1 4-EB

Lamp Used - 54 Watt T5HO
 Racking Reflectance 0.5
 Luminaires Mounted at 33 Ft.
 Luminaire Watts = 223

STORAGE AREA LIGHTING LAYOUT AND CALCULATIONS

SCALE: N.T.S.

6.0 LANDSCAPE DESIGN

Landscape Design

The history of the site as an agricultural plot on the University Farms is clearly defined by the hedgerow of mature trees on the North boundary of the site and a paralleling row just north of the South boundary. The hedgerows of trees reinforce that agricultural heritage of the area, something that early on in the design process was recognized as being an important element to be retained. In addition, the mature trees provide an element that help to screen the large building faces and tend to bring down the scale of the building mass. Recognizing that necessary construction operations such as site excavation for the building foundation can have damaging effects on the trees root systems, much consideration has been given to positioning the building so as to minimize the impact, and allowing approximately 90% of the existing trees to be retained.

The focus of the new plantings on site will be mainly along the east side of the building, the public face that is presents itself to passing traffic both vehicular and pedestrian, as well as LRT. The Southeast corner of the building is the public sector, landscaped to present a welcoming image, defining the public entrance and complimenting the building form. The Northeast corner of the building is the service sector with the landscape focusing on screening of activities and surface utilities located along the North side of the building. Generally, planting is expressed in several layers consisting of trees, shrubs, grasses and groundcover, in rectilinear patterns drawn from images of agricultural plots while at the same time expressing some of the building forms on the ground plane. The intent is to provide visual interest both from outside the building and from the inside the building looking out.

Any swales in the landscape developed for the purpose of channeling rainwater, will be treated with native grasses, ground covers and granular materials so as to naturalize their image and eliminate their need for ongoing maintenance such as mowing. The South and West edges of the site have minimal landscape treatment, as it is envisioned that their development will be influenced strongly by the development along the adjacent future service corridors, details which have not yet been defined. The rear of the building will also be developed with minimal landscape treatment so as not to encumber the area designated for future expansion. There is ongoing discussion as to the possibility of programming

the space prior to expansion, for a yet undefined activity which may define the course of landscape development beyond what is currently envisioned as simple sculpting of the landform and turf grass.



Concept Design

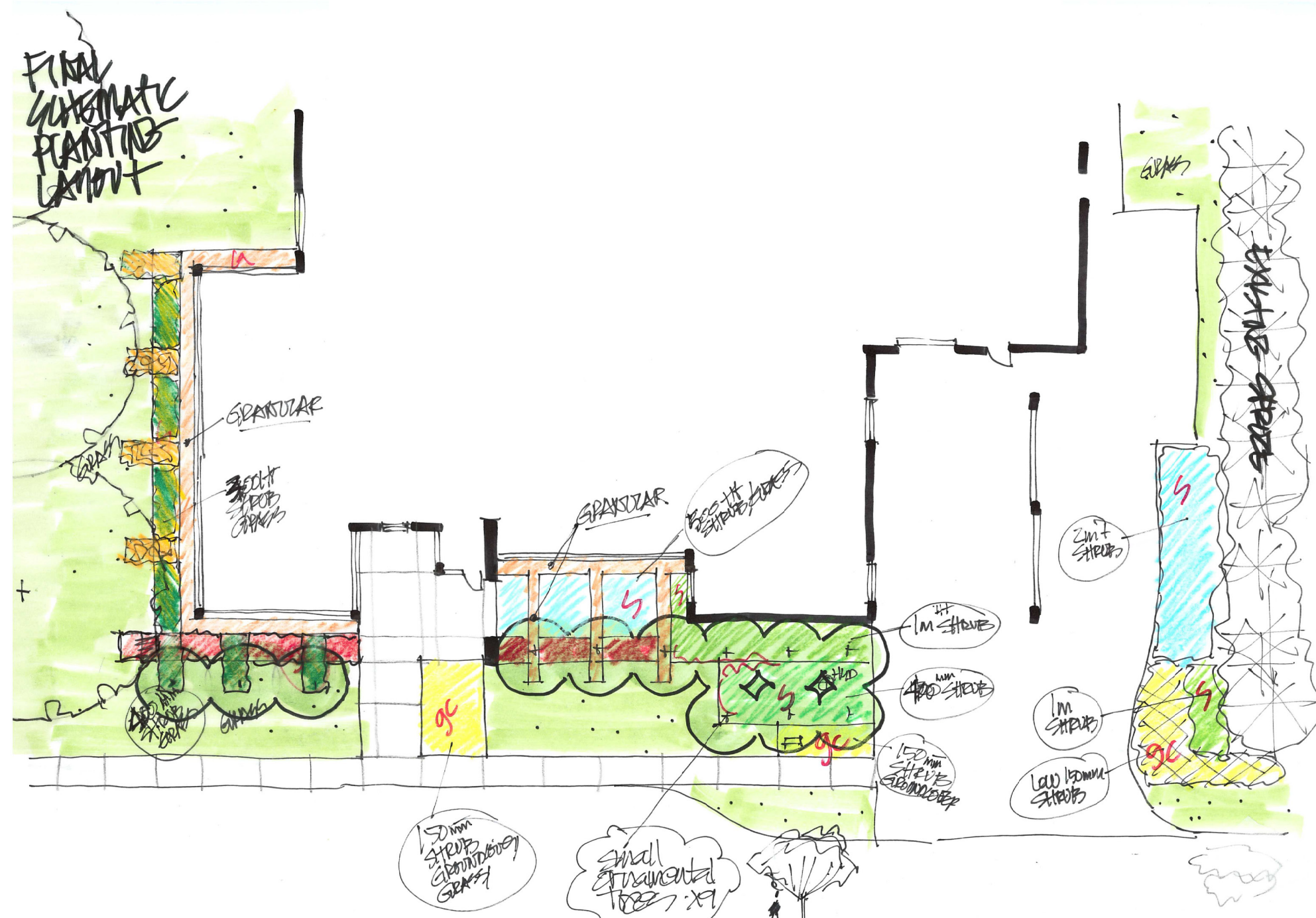

Concept Design Plan

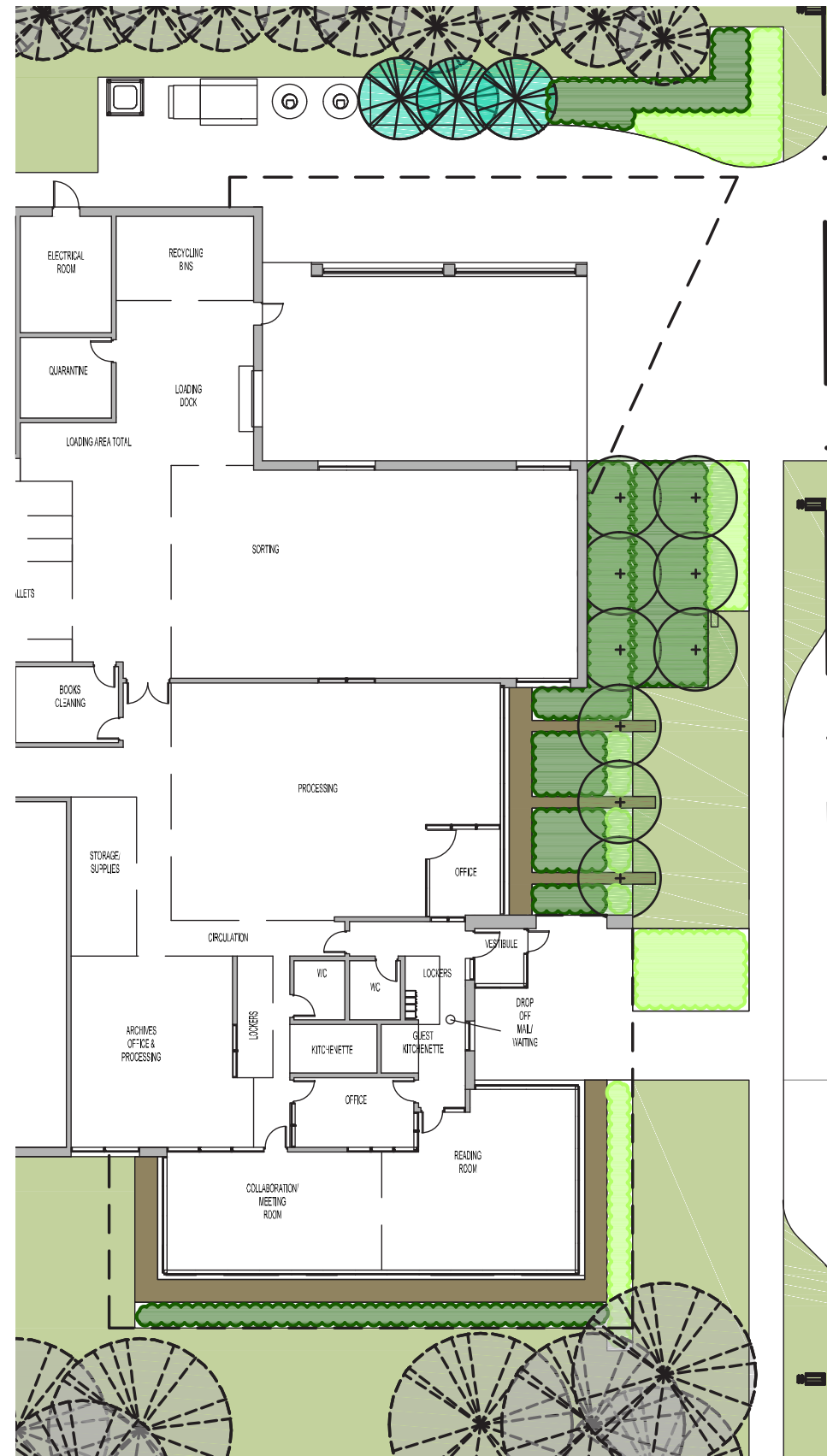

LEGEND

- EXISTING TREE
- PROPOSED ORNAMENTAL TREE
- PROPOSED CONIFEROUS TREE
- PROPOSED SHRUBS
- PROPOSED GRASSES/GROUNDCOVER
- PROPOSED GRASS TURF
- PROPOSED GRANULAR MATERIAL

PAGE INTENTIONALLY LEFT BLANK

7.0 CIVIL DESIGN

Existing Site

The RCRF site is a low-lying vegetated site south of the existing Saville Sports Centre on U of A South Campus. The site is bordered by 115A Street to the east. Topographic information shows the lot is non-draining and varies little in elevation from north to south and east to west. The site is currently un-serviced, scheduled to change in 2016 with plans to extend infrastructure to the site. Geotechnical information shows the lot currently has 300mm of topsoil on site as well as poor soils for economical foundation designs.

Site Servicing

Site servicing for the building will be brought from a location west of the site to entry point locations on or around the building. A new fire hydrant will be placed on the site to aid in fire protection for the RCRF project, the hydrant will have no more than 45m of travel distance to the fire department connection located on the building. Storm sewer services will not be brought to site as the area will utilize surface drainage to convey storm water. Due to the nature of the fire response system in the building, flushing strategies to convey 3000GPM of water for the fire pump testing strategy will need to be considered as it relates to conveying flows without major erosion in the surface drainage systems.

Site Grading

Minimum slopes of 1% and maximum slopes of 4% will be utilized where vehicle and pedestrian traffic is expected. Storm water will be conveyed from the roof area, loading dock area and pedestrian areas through the use of surface drainage and will ultimately enter a ditch system that is to be established on the north and south sides of the building. Drainage ditches will convey the storm water to culvert crossings (under 115A Street) to a major drainage ditch that ultimately makes its way to a dry pond located southeast of the RCRF project.

Future Considerations

Infrastructure as described above and installed as part of the RCRF project may be adequate to service the expansion of the building or other projects planned for this parcel of land, depending on magnitude.

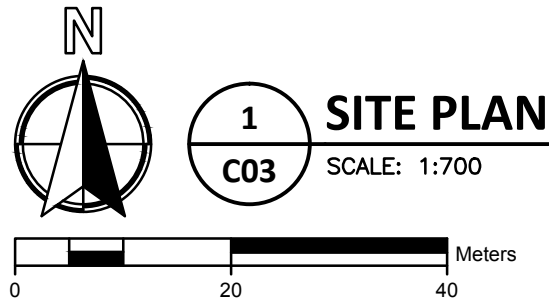
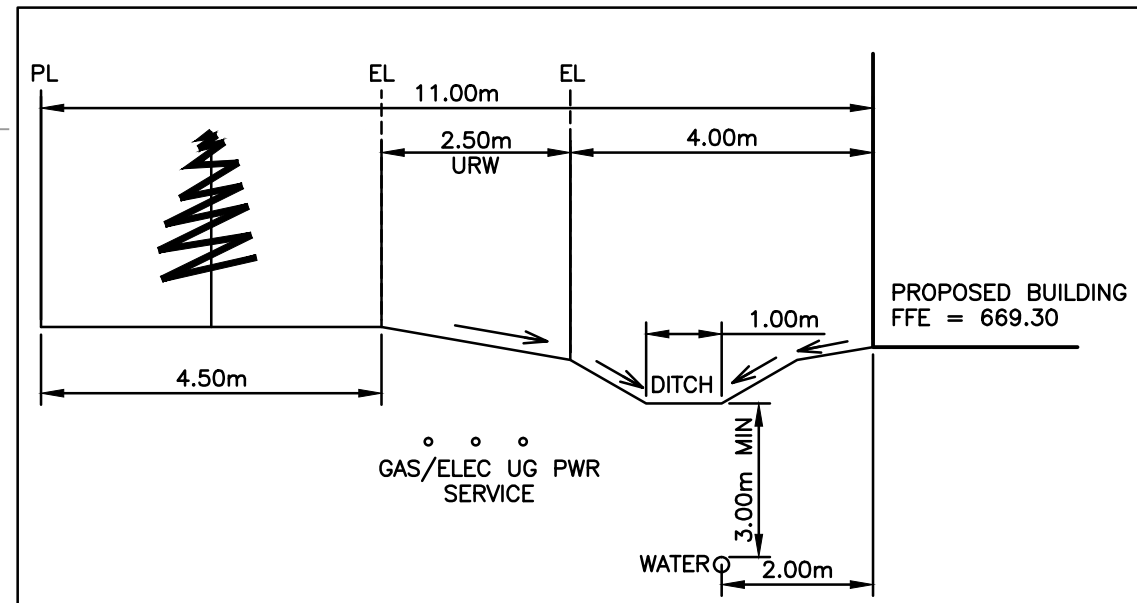
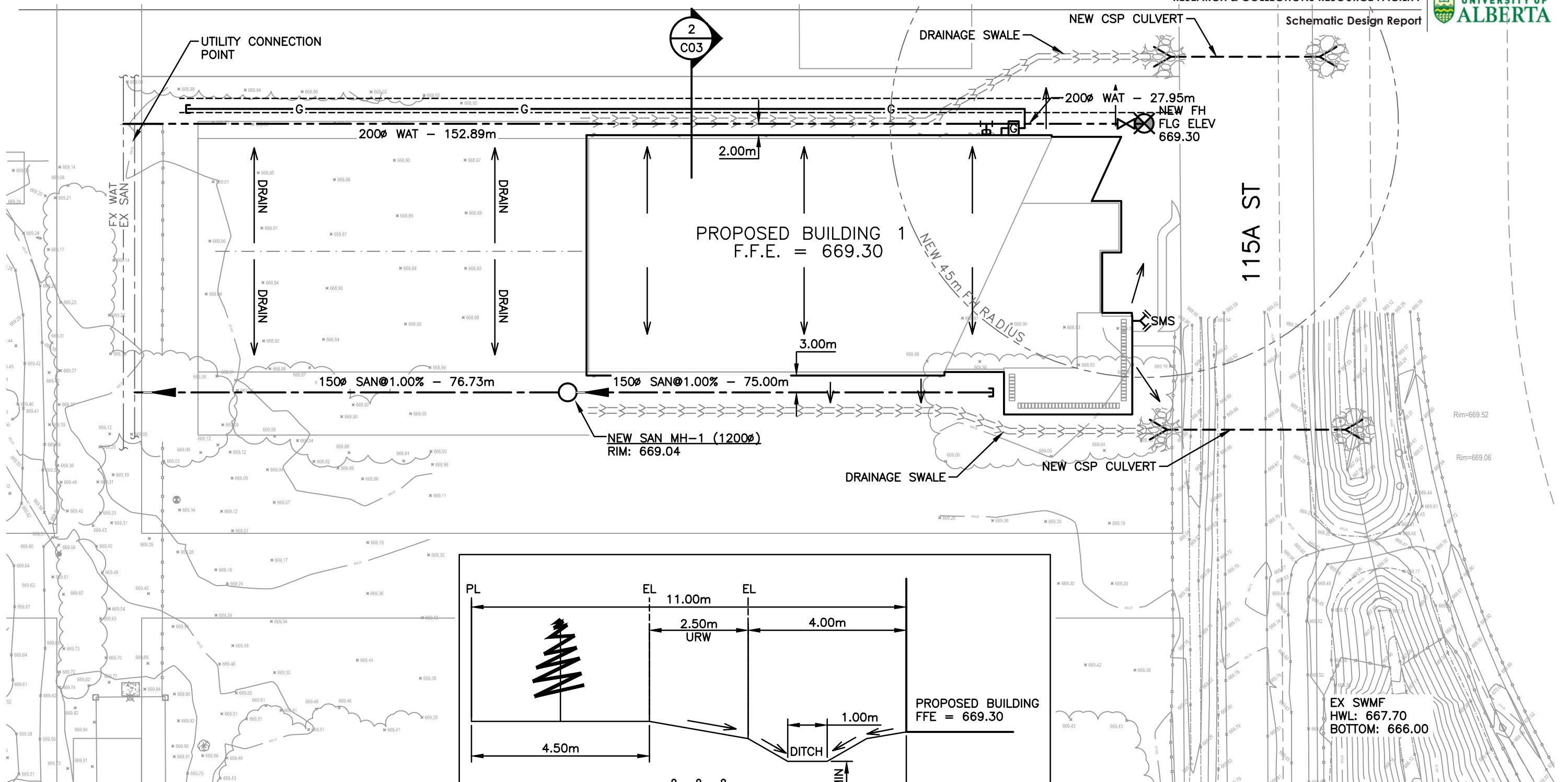

APPENDICES

PAGE INTENTIONALLY LEFT BLANK

Appendix A: Project Schedule

The concept design presented herein can be constructed within the proposed project schedule. Stuart Olson is developing a project schedule that notes the key milestone dates which have been established.

Appendix B: Cost Plan

A Cost Plan has been prepared by Stuart Olson and is excluded from this report. It is available as a separate document but reflects the design concept presented herein.