

The following Motion and Documents were considered by the GFC Facilities Development Committee at its Thursday, June 19, 2014 meeting:

Agenda Title: **Gathering Place – Schematic Design Report**

CARRIED MOTION: THAT the GFC Facilities Development Committee approve, under delegated authority from General Faculties Council and on the recommendation of Planning and Project Delivery, the proposed Gathering Place – Schematic Design Report (as set forth in Attachment 2) as the basis for further planning.

Final Item: 4

OUTLINE OF ISSUE

Agenda Title: **Gathering Place – Schematic Design Report**

Motion: THAT the GFC Facilities Development Committee approve, under delegated authority from General Faculties Council and on the recommendation of Planning and Project Delivery, the proposed Gathering Place – Schematic Design Report (as set forth in Attachment 2) as the basis for further planning.

Item

Action Requested	<input checked="" type="checkbox"/> Approval <input type="checkbox"/> Recommendation <input type="checkbox"/> Discussion/Advice <input type="checkbox"/> Information
Proposed by	Don Hickey, Vice-President (Facilities and Operations)
Presenters	Ben Louie, University Architect, Facilities and Operations; Shana Dion, Director, Aboriginal Student Services Centre; Tracy Bear, Special Advisor to the Provost, Office of the Provost and Vice-President (Academic); Craig Webber, Principal, Group2 Architecture Interior Design Ltd
Subject	Gathering Place – Schematic Design Report

Details

Responsibility	Vice-President (Facilities and Operations)
The Purpose of the Proposal is (please be specific)	To obtain approval for the Schematic Design Report for the Gathering Place.
The Impact of the Proposal is	To provide further planning, funding application, and fundraising efforts towards the realization of constructing a Gathering Place on the North Campus in support of the University's Comprehensive Institutional Plan (CIP).
Replaces/Revises (e.g., policies, resolutions)	N/A
Timeline/Implementation Date	N/A
Estimated Cost	N/A
Sources of Funding	N/A
Notes	N/A

Alignment/Compliance

Alignment with Guiding Documents	<i>Dare to Discover</i> ; Academic Plan (<i>Dare to Deliver</i>); University of Alberta Comprehensive Institutional Plan (CIP); Long Range Development Plan (LRDP)
Compliance with Legislation, Policy and/or Procedure Relevant to the Proposal (please quote legislation and include identifying section numbers)	1. Post-Secondary Learning Act (PSLA): The <i>PSLA</i> gives GFC responsibility, subject to the authority of the Board of Governors, over academic affairs (Section 26(1)) and provides that GFC may make recommendations to the Board of Governors on a building program and related matters (Section 26(1) (o)). Section 18(1) of the <i>PSLA</i> give the Board of Governors the authority to make any bylaws “appropriate for the management, government and control of the university buildings and land.” Section 19 of the <i>Act</i> requires that the Board “consider the recommendations of the general faculties council, if any, on matters of academic import prior to providing for (a) the support and maintenance of the university, (b) the betterment of existing buildings, (c) the construction of any new buildings the board considers necessary for the purposes of the university [and] (d) the furnishing and equipping of the existing and newly erected buildings [.] [...]” Section 67(1) of the <i>Act</i> governs the terms under which university land may be leased.

	<p>2. GFC Facilities Development Committee (FDC) Terms of Reference – Section 3. Mandate of the Committee: “[...]”</p> <p>2. Delegation of Authority</p> <p>Notwithstanding anything to the contrary in the terms of reference above, the Board of Governors and General Faculties Council have delegated to the Facilities Development Committee the following powers and authority:</p> <p>A. Facilities</p> <p>1. To approve proposed General Space Programmes (Programs) for academic units.</p> <p>2. (i) To approve proposals concerning the design and use of all new facilities and the repurposing of existing facilities and to routinely report these decisions for information to the Board of Governors.</p> <p>(ii) In considering such proposals, GFC FDC may provide advice, upon request, to the Provost and Vice-President (Academic), Vice-President (Facilities and Operations), and/or the University Architect (or their respective delegates) on the siting of such facilities. (GFC SEP 29 2003)</p> <p>B. Other Matters</p> <p>The Chair of FDC will bring forward to FDC items where the Office of the Provost and Vice-President (Academic) and/or the Office of the Vice-President (Facilities and Operations), in consultation with other units or officers of the University, is seeking the advice of the Committee. [...]</p> <p>3. UAPPOL Space Management Policy and Space Management Procedure: The respective roles of GFC FDC and the Vice-President (Facilities and Operations) with regard to institutional space management are set out in this Board-approved Policy and attendant Procedure.</p> <p>To access this policy suite on line, go to: www.uappol.ualberta.ca.</p>
--	--

Routing (Include meeting dates)

<p>Consultative Route (parties who have seen the proposal and in what capacity)</p>	<ul style="list-style-type: none"> • University of Alberta Aboriginal Advisory Council – 1998; • Aboriginal Strategies Task Force – 2001; • Indigenous Centre Committee – 2002; • The Aboriginal Gathering Place Visioning Process (Visioning Session on April 7, 2008 and Programming Session on September 4, 2008, with key stakeholders from the University of Alberta, the Aboriginal Initiative Working Group, elders, faculty, and student representatives); • University of Alberta Aboriginal Gathering Place – Visioning and Programming Study (May, 2009); • Gathering Place Project Steering Committee (October, 2013; May,
---	--

FINAL Item No. 4

	2014); • This study was presented to the Council of Aboriginal Initiatives by Tracy Bear, Shana Dion, and Chelsea Boucher (Office of the Registrar) – April 9, 2014
Approval Route (Governance) (including meeting dates)	GFC Facilities Development Committee (June 19, 2014) – for approval
Final Approver	GFC Facilities Development Committee

Attachments:

1. Attachment 1 (pages 1 – 2) - Briefing Note
2. Attachment 2 (pages 1 – 81) - Gathering Place – Schematic Design Report (June 4, 2014)

Prepared by: Ben Louie, University Architect, Office of the University Architect, Planning and Project Delivery, Facilities and Operations, ben.louie@ualberta.ca

Gathering Place – Schematic Design Report Briefing Note

Attachment 1

Background

The vision for the Gathering Place is to provide a foundation for education, research and community engagement for Indigenous people of all ages - providing leadership development for a significant generation of Alberta's youth. From that developing foundation, the hope they can build will transform their futures, and ours.

The Gathering Place will affirm the cultural identity of this important next generation of Indigenous youth, and allow all students, faculty and the wider community to share in the culture and values that distinguish Indigenous society. It will be a symbol of good will, unity and intersection.

Open to the greater university body, the Gathering Place will function as a cross-faculty centre of learning in order to facilitate a higher quality of dialogue between Aboriginal students and staff and all academic disciplines at the University of Alberta.

The journey of the Gathering Place has been guided and shaped by the efforts and wisdoms generated by members of past committees:

- University of Alberta Aboriginal Advisory Council – 1998;
- Aboriginal Strategies Task Force – 2001;
- Indigenous Centre Committee – 2002;
- The Aboriginal Gathering Place Visioning Process – 2008;
- University of Alberta Aboriginal Gathering Place – Visioning and Programming Study (May 2009);
- Gathering Place – Functional Programme and Site Study – GFC Facilities Development Committee - July 26, 2012 – for approval;
- Gathering Place Project Steering Committee – October 2013 – May 2014; and
- This study was presented to the Council of Aboriginal Initiatives by Tracy Bear, Shana Dion, and Chelsea Boucher, April 9, 2014.

In addition, it has been shaped by direct operational input from the following locations:

- Migizii Agamik (Bald Eagle House), University of Manitoba;
- First Peoples House of Learning, Trent University;
- First Nations House of Learning, University of British Columbia;
- First People's House, University of Victoria; and
- Shq'apthut (Gathering Place in Hul'q'umi'num), Vancouver Island University.

The design process was supported by the Gathering Place Project Steering Committee from October 2013 – May 2014.

An interactive design workshop was held on January 17, 2014. Participants included the members of the Project Steering Committee and invited members of the Aboriginal community on campus. Discussion focused on how spaces would be used by different groups ("a day in the life"), expression of cultural identity through architectural elements, spatial/functional relationships and quality of interior space.

The draft schematic design was presented to the Council on Aboriginal Initiatives (CAI) on April 9, 2014 by Tracy Bear, Shana Dion, Chelsea Boucher, (Kim Woodroffe and James Townsend, Group2 Architecture Interior Design Ltd.).

Issues

The purpose of this study is to refine the scope and planning strategy to respond to the proposed site for the facility in the heart of the north campus, directly north of the Education Building. In this location, the Gathering Place is able to benefit from synergies with amenities and support spaces existing in the North Education Building while providing an opportunity to create the necessary amenities and resources for Aboriginal students.

The Functional Programme includes:

- cultural space;
- knowledge commons;
- administrative space;
- building services; and
- circulation spaces.

Cultural space includes a great hall, gallery/exhibit areas, multi-functional space/lobby, kitchen and coat room and assigned storage. Three program areas were added within the schematic design stage. They include the smudge room, the truth and reconciliation room and a change room.

The knowledge common includes computer area/level one commons, quiet study, gathering/level two commons, classroom and transitional year program room. An additional quiet room was also deemed to be required.

Administrative space includes reception, offices for the Aboriginal Student Services Centre director, special advisor, transitional year program co-ordinator, counselor, administrative assistant, Aboriginal liaison, Aboriginal student advisor, Aboriginal student council, elder's room and two support staff. An additional meeting room and a small admin storage area was deemed to be required.

Building services includes mechanical/electrical services, water metre room, server/electrical room, washroom and custodial area.

The Project Steering Committee, together with the consultant team, worked through site design issues including planning objectives, pathways and connections site constraints and landscape, as well as, architectural design issues including qualities of space, material palette, precedents, floor plans, sections and elevations, interior design and cultural identity.

Recommendation

THAT the GFC Facilities Development Committee approve the proposed Gathering Place – Schematic Design Report.

GATHERING PLACE

SCHEMATIC DESIGN REPORT

UNIVERSITY OF ALBERTA

JUNE 4TH 2014





TABLE OF CONTENTS

- 1.0 INTRODUCTION
 - 1.1 Executive Summary
 - 1.2 Project Evolution
 - 1.3 Acknowledgments

- 2.0 SCHEMATIC DESIGN
 - 2.1 Program Reconciliation
 - 2.2 Architectural Design
 - 2.2.1 Qualities of Space
 - 2.2.2 Material Palette
 - 2.2.3 Precedents
 - 2.2.4 Floor Plans
 - 2.2.5 Sections and Elevations
 - 2.3 Site Design
 - 2.3.1 Planning Objectives
 - 2.3.2 Pathways + Connections
 - 2.3.3 Site Constraints
 - 2.3.4 Landscape
 - 2.4 Interior Design
 - 2.4.1 Interior Layouts
 - 2.5 Cultural Identity

- 3.0 REGULATORY ANALYSIS
 - 3.1 Building Code Analysis

- 4.0 SUSTAINABLE STRATEGIES

- 5.0 STRUCTURAL SYSTEMS

- 6.0 MECHANICAL SYSTEMS

- 7.0 ELECTRICAL SYSTEMS

1.0 INTRODUCTION

1.1 EXECUTIVE SUMMARY

Our vision is for the Gathering Place to provide a foundation for education, research and community engagement for Indigenous people on the University of Alberta Campus. It is our intention to build a place of hope for Indigenous people where leadership development is provided for a significant generation of Alberta's youth. The Gathering Place will also celebrate the value of past, present and future contributions to the community by Indigenous people and culture.

This document was prepared for the University of Alberta with the intention of providing a summary of the progress made on the Gathering Place project during the Schematic Design Phase.

Program Reconciliation summarizes the spaces at the end of Schematic Design in comparison to the program as included in the *2012 Functional Programme and Site Study*. There is an overall increase in area of approximately 15% which includes the addition of a Truth & Reconciliation Room, Smudge Room, Change Room as well as Quiet Study and Meeting Spaces.

Architectural Design incorporates gathering, sharing of culture and inclusiveness as central themes. The Great Hall and smaller, informal meeting spaces will be available to the Aboriginal community and to the wider campus community to hold important educational, ceremonial, celebratory and other special events. Aboriginal Student Services and Administration, student groups and tutoring services will also be located in this rich environment.

A variety of exhibit spaces will provide the opportunity for showcasing the University of Alberta's significant Indigenous art and anthropological holdings.

Cultural affirmation is a powerful tool in the development of leadership. It provides the self-confidence for people to envision themselves as leaders, and then to define and pursue positive leadership roles. The Gathering Place will provide a setting to affirm

the cultural identity of multi-generational Indigenous students, and allow all students, faculty and the wider community to share in the culture and values that distinguish Indigenous society. It will be a symbol of good will, unity and intersection, and a home for the Aboriginal community on campus.

The journey of the Gathering Place has been guided and shaped by the efforts and knowledge generated by members of past committees:

- University of Alberta Aboriginal Advisory Council 1998
- Aboriginal Strategies Task Force 2001
- Indigenous Centre Committee 2002
- The Aboriginal Gathering Place Visioning Process 2008
- Visioning and Programming Study 2009
- Functional Programme and Site Study 2012

An interactive design workshop was held on January 17, 2014. Participants included the members of the Design Committee and members of the Aboriginal community on campus. Discussion focused on how spaces would be used by different groups ("a day in the life"), expression of cultural identity through architectural elements, spatial/functional relationships and quality of interior space.

The schematic design was presented to the Council on Aboriginal Initiatives (CAI) on April 9, 2014 by Tracy Bear, Shana Dion, Chelsea Boucher, Kim Woodroffe and James Townsend.

A primary focus of the Gathering Place has always been to provide a space for Cultural functions for Indigenous students, their communities, the University of Alberta and the greater Community. The Gathering Place will be open to all University staff, students and visitors functioning as a cross-faculty centre of learning to facilitate a high quality of dialogue between Aboriginal students and staff and all Academic disciplines at the University of Alberta.

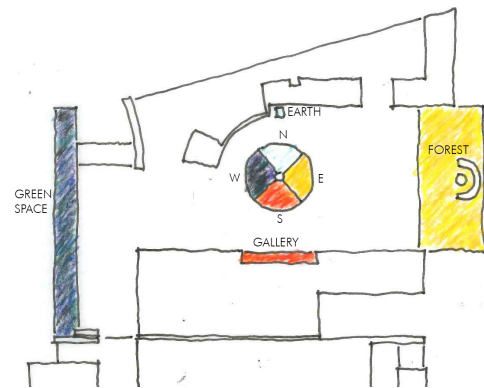

MEDICINE WHEEL

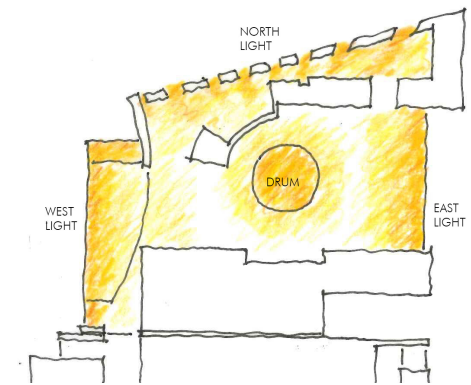

LEVEL 2 - DAYLIGHT

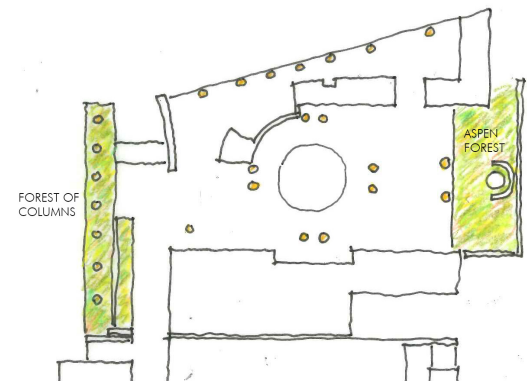

FOREST

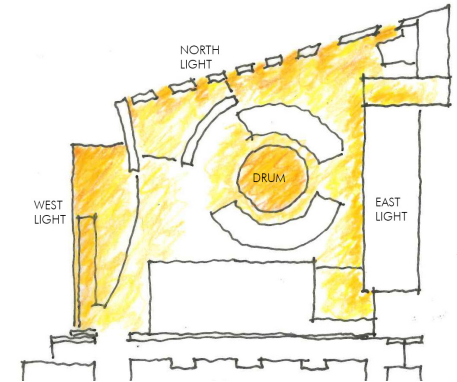

LEVEL 1 - DAYLIGHT

1.2 PROJECT EVOLUTION

The Schematic Design builds on the foundations of previous work, most recently the *Functional Programme and Site Study* published in July 2012. Through the schematic design process, including the design workshop held in January 2014, a number of changes and refinements have been made to the program while building systems, materials and cultural imagery have been further developed.

PROGRAM

The following spaces were identified as important for day-to-day functions within the building, and added to the original functional program: Smudge Room, Change Room, Meeting Room, and the Truth and Reconciliation Committee (TRC) Room. Service space was increased at the basement level to accommodate mechanical HVAC systems within the building, eliminating the need for rooftop equipment.

MATERIALS AND CONNECTION TO NATURE

Respecting the importance of the nature within Aboriginal culture, selected materials and finishes include wood and rammed earth. Heavy timber structural elements including columns speak of connection to the native aspen forest. The rammed earth wall makes reference to layers of sediment, the passage of time and past generations.

Design of spaces and elements are intended to evoke a natural setting, with access to daylight and expansive views directed to landscaped areas. Organic, circular forms are used for the Drum, the sweeping curve of the rammed earth wall and the second floor opening to the Lobby.

CULTURAL IMAGERY

Ideas on appropriate imagery and references to Aboriginal culture resulted in much discussion at the workshop and subsequent meetings.

The following elements have become integral to the design:

- The drum representing the call to gathering, an invitation to students of various Aboriginal backgrounds
- The four elements of earth, sky, water and fire.
- The tipi offering shelter and protection.
- Petroglyphs as a source of inspiration for contemporary artwork and celebration of culture.

1.3 ACKNOWLEDGMENTS

We would like to thank the amazing team of individuals who contributed to the Schematic Design for the University of Alberta Gathering Place. The open, engaging and productive nature of this group allowed the design to evolve to its present state.

UNIVERSITY OF ALBERTA

GATHERING PLACE SCHEMATIC DESIGN COMMITTEE

Tracy Bear
 Chelsea Boucher
 Shana Dion
 Pat Jansen
 Ben Louie
 Fern Snart
 Todd Werre
 Randolph Wimmer

DESIGN WORKSHOP ATTENDEES

Suzanne Butler
 Krista Chiponski
 Florence Glanfield
 Kristen Mineault
 Alana Okanee

GROUP2 ARCHITECTURE

Craig Webber
 James Townsend
 Kim Woodroffe
 Akindele Oladunmoye
 Garret Yaceyko
 Cailey Gray

SUB-CONSULTANTS

Matt Fenwick - Williams Engineering (Electrical Engineering)
 Duane Palibroda - Fast & Epp (Structural Engineering)
 Bill Temple - Williams Engineering (Mechanical Engineering)

Special thanks to the Council on Aboriginal Initiatives (CAI) for their valuable contributions.

PROGRAM - SUMMARY

SPACE DESCRIPTION	PROGRAM AREA		SCHEMATIC AREA	
	m ²	ft ²	m ²	ft ²
SUMMARY				
Cultural Space	660	7,104	775	8,342
Knowledge Commons	430	4,629	430	4,628
Administrative	153	1,647	205	2,207
Building Services	200	2,153	319	3,434
Circulation	-	-	574	6,178
SUB TOTAL	1,443	15,532	2,303	24,789
Wall Gross	-	-	104	1,119
Building Gross Factor (35%)	505	5,436	-	-
Program Contingency (10%)	144	1,553	-	-
TOTAL	2,092	22,522	2,407	25,909

PROGRAM - OUTDOOR SPACE

SPACE DESCRIPTION	PROGRAM AREA		SCHEMATIC AREA	
	m ²	ft ²	m ²	ft ²
OUTDOOR SPACE (not included in building sub-total)				
Loading	-	-	32	344
Elders' Garden	60	646	55	592
Terrace	150	1,615	86	926
SUB TOTAL	210	2,260	173	1,862

2.0 SCHEMATIC DESIGN

2.1 PROGRAM RECONCILIATION

The current Schematic Program areas are summarized to the left and are compared to the areas as included in the *Functional Program and Site Study* document dated July 2012.

Line items identified in red text are spaces that were not previously part of the program. Other deviations from the original program include an increase in storage space, multi-functional/lobby area, and service space to accommodate all mechanical systems within the building. Although student knowledge commons space appears reduced on both levels from the original program, it is similar in total area as calculations no longer include adjacent circulation space.

Overall, the building area is increased by 15% including the partial basement, while the area of outdoor space is slightly reduced from the original program.

Spaces that have been added to the program are as follows:

Smudge Room (10m²) - This room is a space for smudging and includes a ventilation system. The location is on the main floor just beyond reception for convenient access to students, staff and visitors.

PROGRAM - DETAILS

SPACE DESCRIPTION	PROGRAM AREA		SCHEMATIC AREA	
	m ²	ft ²	m ²	ft ²
CULTURAL SPACE				
Great Hall	425	4,575	413	4,445
Great Hall Storage	45	484	44	474
Gallery/ Exhibit	50	538	46	495
Gallery/ Exhibition Storage	20	215	47	506
Multifunction Space/Lobby	50	538	123	1,324
Kitchen	60	646	61	657
Coat Room	10	108	-	-
Smudge Room	-	-	10	108
Truth & Reconciliation Room	-	-	15	161
Change Room	-	-	16	172
SUB TOTAL	660	7,104	775	8,342
KNOWLEDGE COMMONS				
Computer Area/Level 1 Commons	100	1,076	84	904
Quiet Study	90	969	93	1,001
Gathering/Level 2 Commons	80	861	61	657
Classroom	80	861	81	872
TYP Program Room	80	861	80	861
Quiet Room	-	-	31	334
SUB TOTAL	430	4,628	430	4,628

SPACE DESCRIPTION	PROGRAM AREA		SCHEMATIC AREA	
	m ²	ft ²	m ²	ft ²
ADMINISTRATIVE				
Reception	15	161	21	226
Office - ASSC Director	15	161	15	161
Office - Special Advisor	15	161	15	161
Office - Transition Year Program Coordinator	11	118	11	118
Office - Counselor	11	118	11	118
Office - Administrative Assistant	11	118	11	118
Office - Aboriginal Liaison	11	118	11	118
Office - Aboriginal Student Advisor	11	118	11	118
Office - Aboriginal Students Council	11	118	11	118
Elder's Room	20	215	22	237
Office - Support Staff	11	118	11	118
Office - Support Staff	11	118	11	118
Meeting Room	-	-	38	409
Admin Storage	-	-	6	65
SUB TOTAL	153	1,647	205	2,207
BUILDING SERVICES				
Mechanical/Electrical Service	100	1,076	223	2,400
Water Metre Room	5	54	-	-
Server/Electrical Room	5	54	6	65
Washrooms	80	861	76	818
Custodial	10	108	14	151
SUB TOTAL	200	2,153	319	3,434
CIRCULATION				
Vestibule	-	-	18	194
Planting	-	-	22	237
Ramp	-	-	43	463
Stair	-	-	48	517
Main Floor Circulation	-	-	139	1,496
Second Floor Circulation	-	-	304	3,272
SUB TOTAL	-	-	574	6,178

Truth & Reconciliation Room (15m²) - This is intended as a private, quiet space for listening to or viewing recordings from the Truth & Reconciliation Commission. It should include soft seating, space for 3 to 4 people at a time and audio/visual equipment. This room will likely require the involvement of an exhibit designer during the Design Development phase.

Change Room (16m²) - It was identified that a place is required for performer's to change and store belongings. Lockers will be included within this room.

Quiet Room (31m²) - This is a quiet study space with views to the Elder's garden. The area is essentially part of the Knowledge Commons.

Meeting Room (38m²) - It was identified that a meeting room for approximately 8-10 people is required. The space can be made available for bookings when not in use.

Loading (32m²) - The loading area exists at the north side of the Education building. This back door access point will remain and be modified to suit both buildings.

The Gathering Place is essentially an addition to the Education North building and shares a number of programmatic synergies. The 2012 *Functional Programme and Site Study* indicates approximately 2200 m² of shared space including Student Commons, Food

Services, a Lecture Hall, Classrooms, Labs, Library space as well as Digital Recording and TV Sound Studios. Elevators are located along the main corridor of the Education North building just before the entrance to the Gathering Place addition. Due to this close proximity, elevators have not been added to the Gathering Place program.

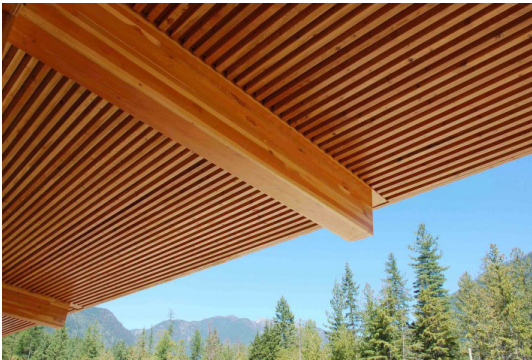

2.2 ARCHITECTURAL DESIGN

2.2.1 Qualities of Space

The Gathering Place will be many things to many people: a place of gathering and interaction, a place of learning, a place of reflection, and a home to celebrate aboriginal culture. Accordingly, the design seeks to create a diversity of spaces.

The Entrance and Lobby form the public face of the building, with a transparent quality that allows the activity and movement of people to animate both interior and exterior spaces. This space is all about presenting the Gathering Place to the aboriginal community, students, faculty and the general public.

The Great Hall is an adaptable, multi-functional space that can be opened up or closed off to engage the wider campus or to look inwards. Within Aboriginal culture, the drum has always been used for the call to gathering, represented in the double-height space at the centre of the building. Visual connection to the aspen “forest” offers a connection to nature.

Knowledge Commons spaces at both levels provide places for interaction, whether it be larger groups of students or a one-on-one discussion. The second level spaces offer a variety of settings, with connection to the Drum, the more animated Lobby space, the more private area to the north, a Quiet Room, and the garden terrace.

2.2.2 Material Palette

Natural materials and finishes are featured to create a quality of space grounded in nature, and a positive learning environment that nurtures success.

WOOD

Exposed heavy timber framing creates a vast roof plane that shelters the spaces below. The warm character of wood is also present in wood columns, feature ceilings and hardwood flooring at the Great Hall.

EARTH/STONE

Connection to the earth is expressed through the rammed earth entry wall, and textured precast concrete panels at the north facade. Polished cast-in-place concrete columns support the concrete floor structure. Stone or porcelain tile flooring is used at public areas.

GLAZING

Full height glazed walls offer a connection between outside and inside, focusing on green spaces to the east and west. Glazing at the north facade is placed to call attention to columns and the radial grid. Clerestory glazing at the Drum provides daylighting to the core of the building.

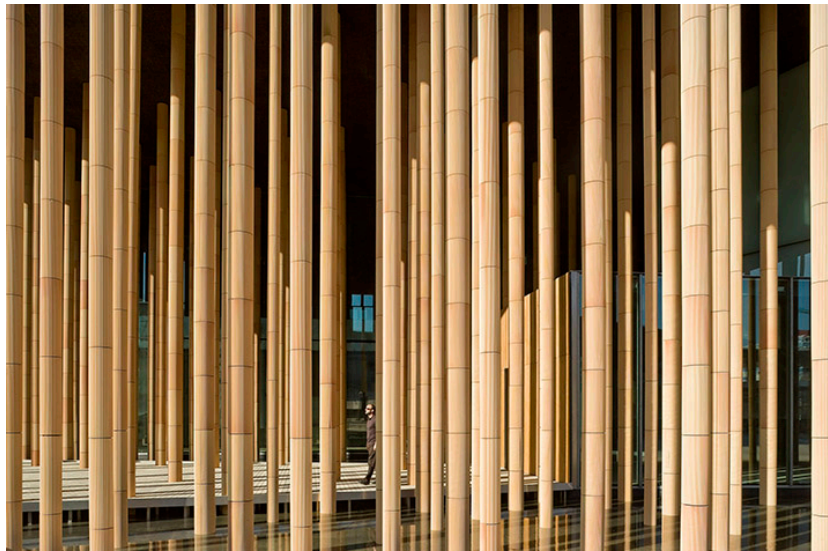

SPANISH PAVILION
ZARAGOZA EXPO 2008
FRANCISCO MANGADO



MIGIZII AGAMIK
UNIVERSITY OF MANITOBA
PRAIRIE ARCHITECTS INC



FIRST PEOPLES HOUSE
UNIVERSITY OF VICTORIA
ALFRED WAUGH



HOUSE OF LEARNING
 THOMPSON RIVERS UNIVERSITY
 DAVID NAIME ARCHITECTS & DIAMOND SCHMITT ARCHITECTS

2.2.3 Precedents

A number of precedents were referenced during schematic design to inspire and further develop the project. These include the following examples,

FIRST PEOPLES HOUSE, University of Victoria

The use of wood, generous roof overhang, totems and glazed walls create a welcoming building that speaks to west coast aboriginal culture.

MIGIZII AGAMIK (BALD EAGLE LODGE), University of Manitoba

The use of wood and stone connect the building to the natural environment.

SPANISH PAVILION, Expo Zaragoza 2008

A forest of columns begins to blur the boundary between interior and exterior.

HOUSE OF LEARNING, Thompson Rivers University

The combination of wood mullions, wood ceilings, concrete columns and neutral colour carpeting creates a harmonious interior space.

2.2.4 Floor Plans

BASEMENT/LEVEL 0

Storage, mechanical and electrical service rooms are located in the basement, with tie-in to existing services at the main corridor of the Education Building.

LEVEL 1

Public circulation and entry occur on the west side, aligned with the Education Building north-south corridor. Glazed walls visually connect to 89th Avenue and green space to the west. Exhibit space defines the transition from this public area to the Great Hall and student and staff spaces. The reception area acts as a welcoming and information point for students and staff, and is located to be less visible to public thoroughfare. Support spaces are located to the south, adjacent to the Education Building and loading dock area. Waste and recycle bins are found to the east of the loading area and there is an opportunity for waste storage within the building near the loading dock entrance.

The circle within the Great Hall is the focal point of the building, with its Drum, a double-height volume natural daylighting. Sliding screens create open or closed space to suit various activities. Views to the outdoors emphasize east-west cardinal directions. The aspen forest and fire pit visually extend the Great Hall space to the outdoors.

LEVEL 2

The Lobby stair provides public access from the main floor and connection to the Education Building north-south corridor. Student spaces are located throughout this level, with staff offices centered around the Drum. The various Knowledge Commons areas each have their own character of space and views. The eastern terrace provides outdoor space for the Elders' Garden and visual connection to the aspen forest.

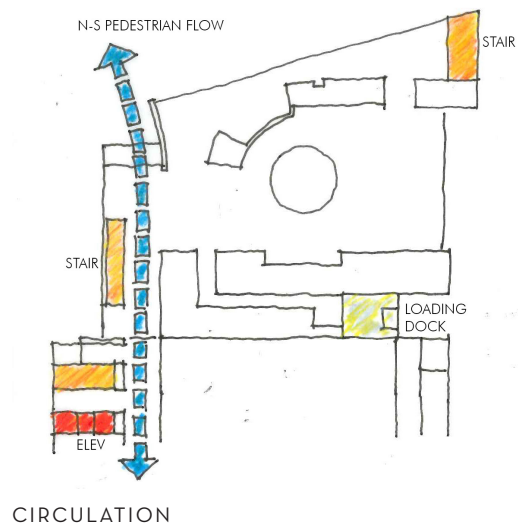

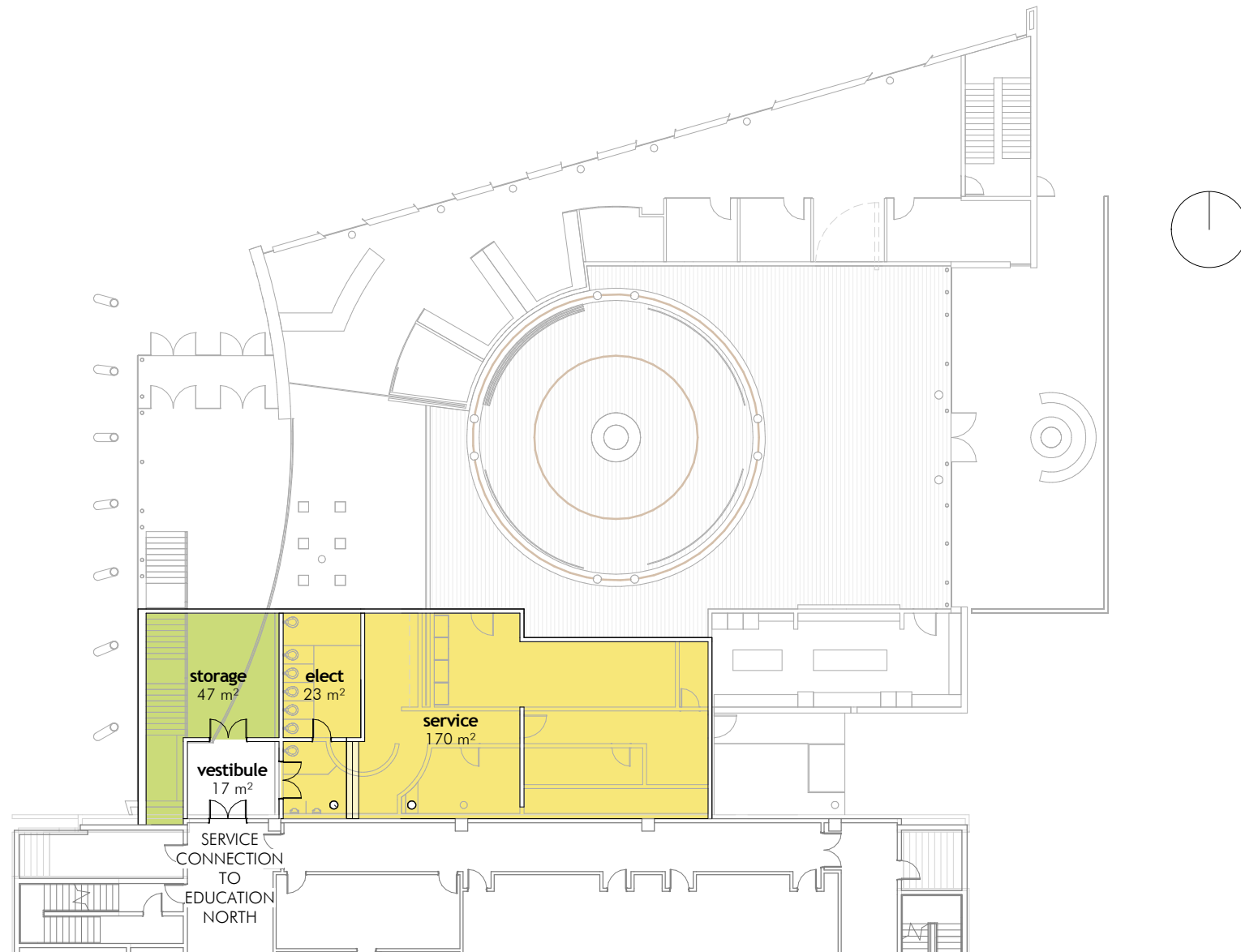

LEVEL 0 PLAN

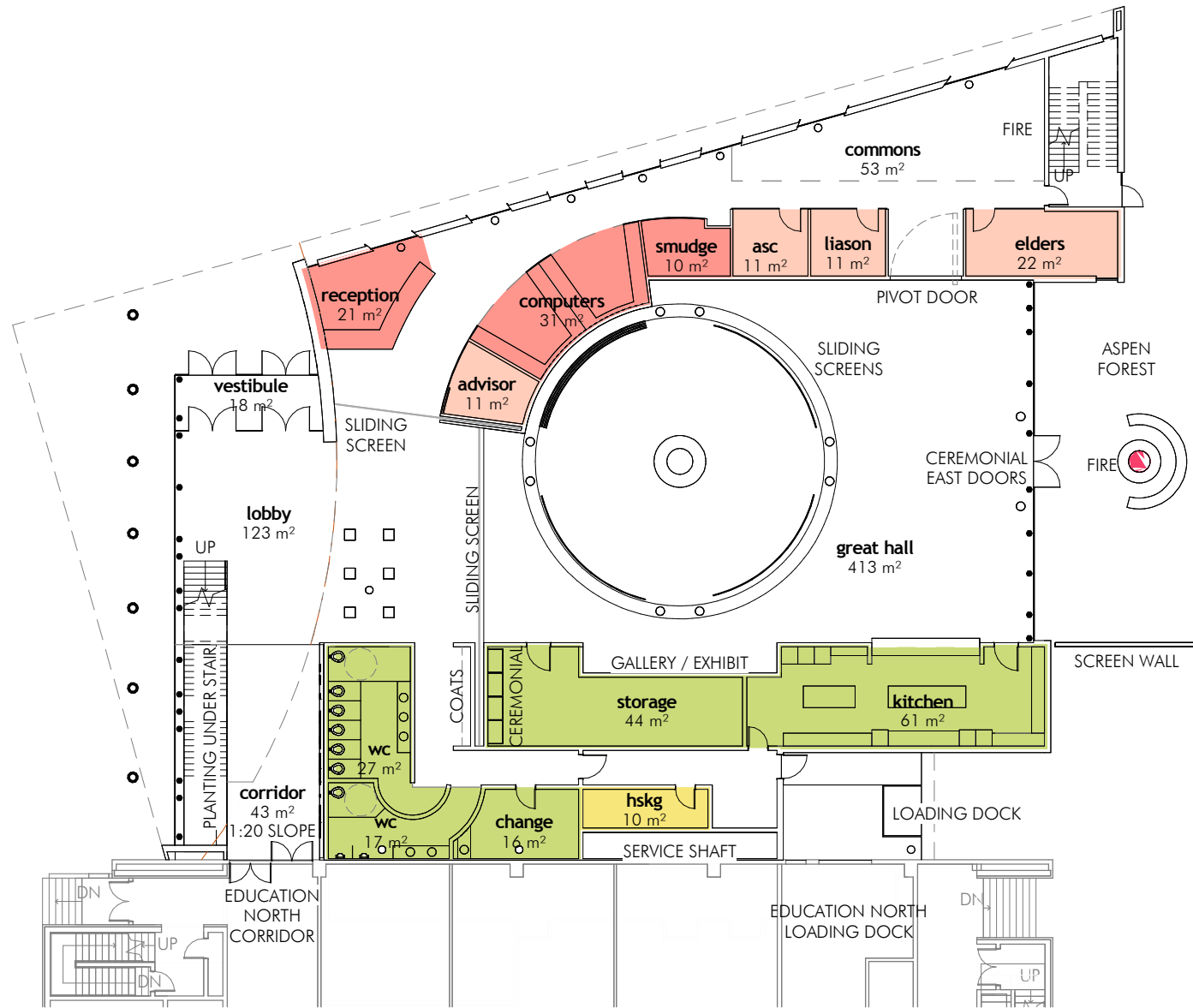

LEVEL 1 PLAN

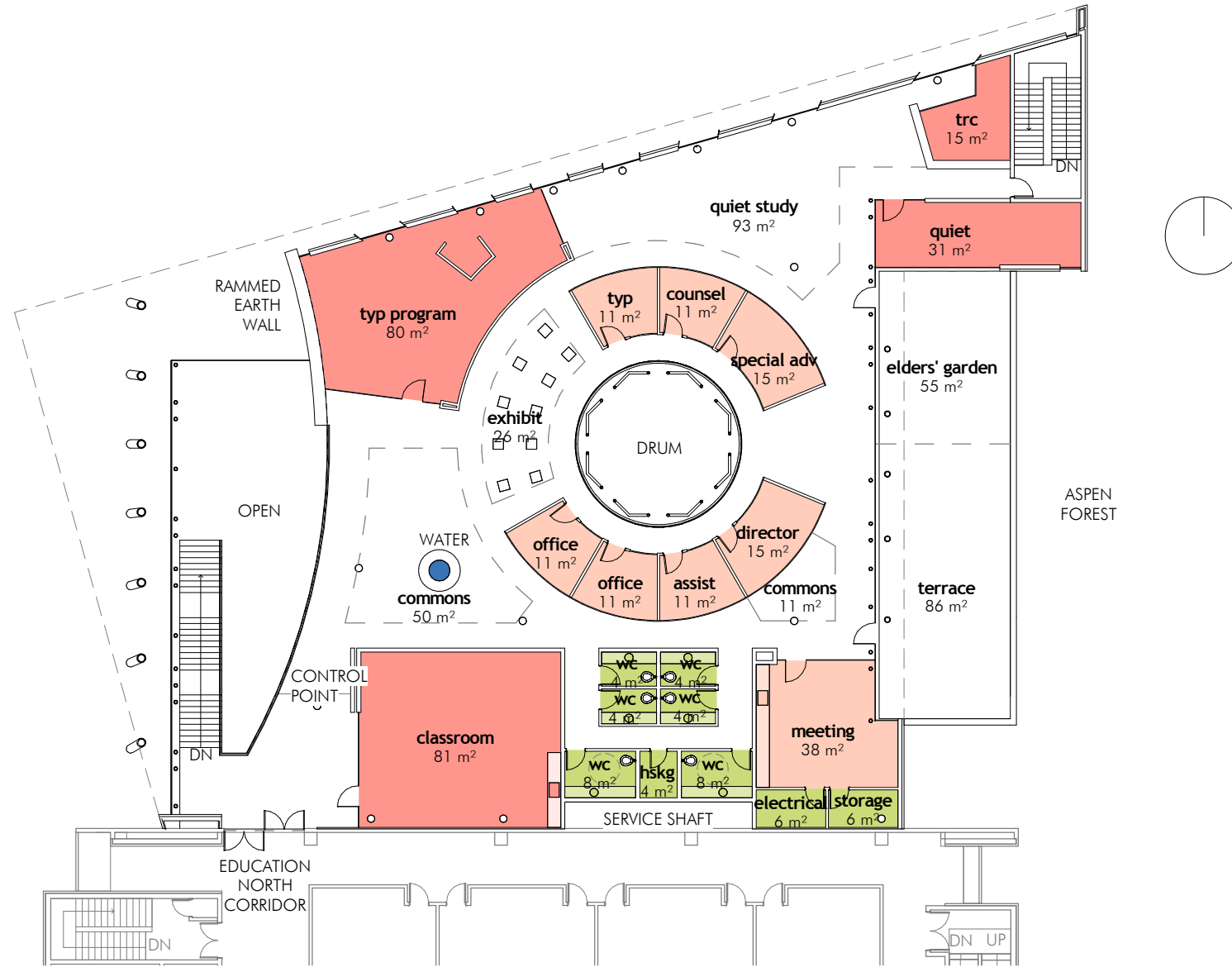

LEVEL 2 PLAN

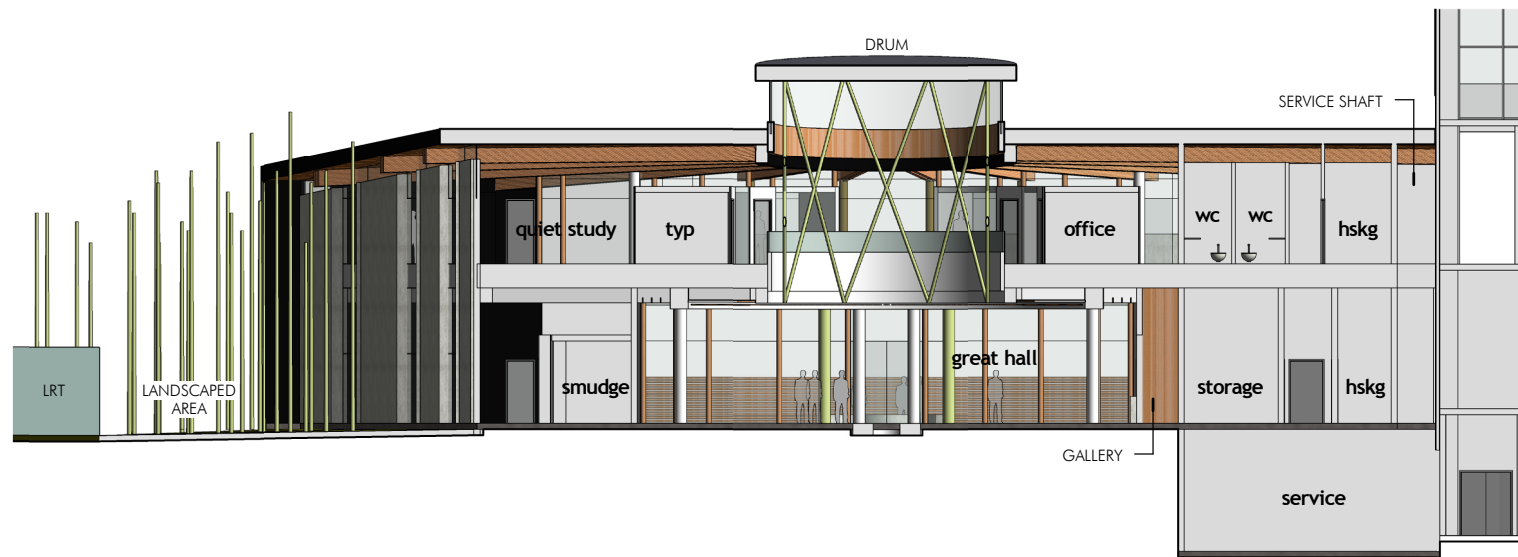

NORTH-SOUTH SECTION THROUGH DRUM

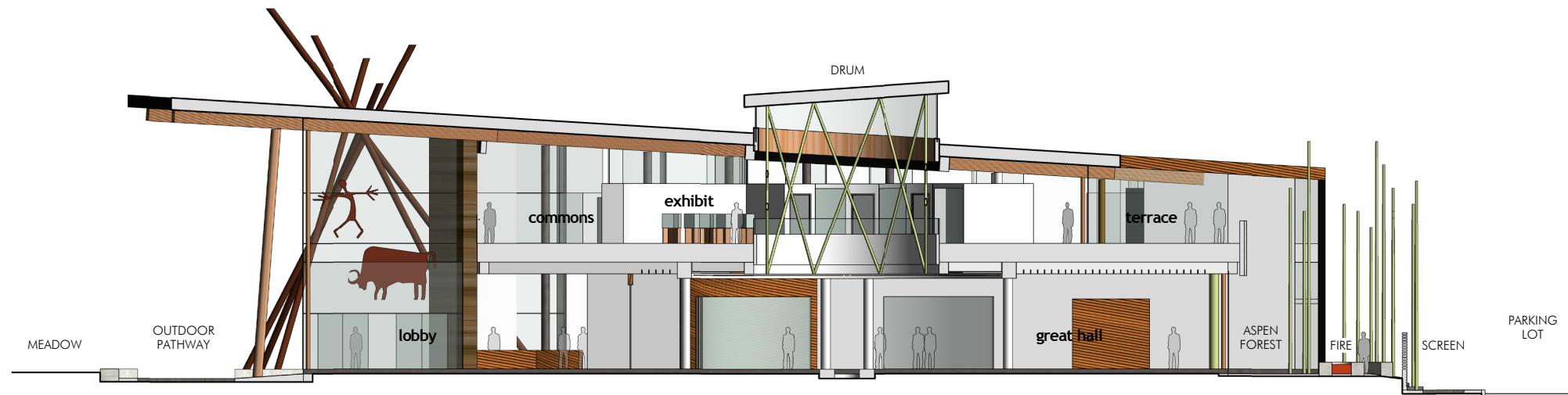

EAST-WEST SECTION THROUGH DRUM

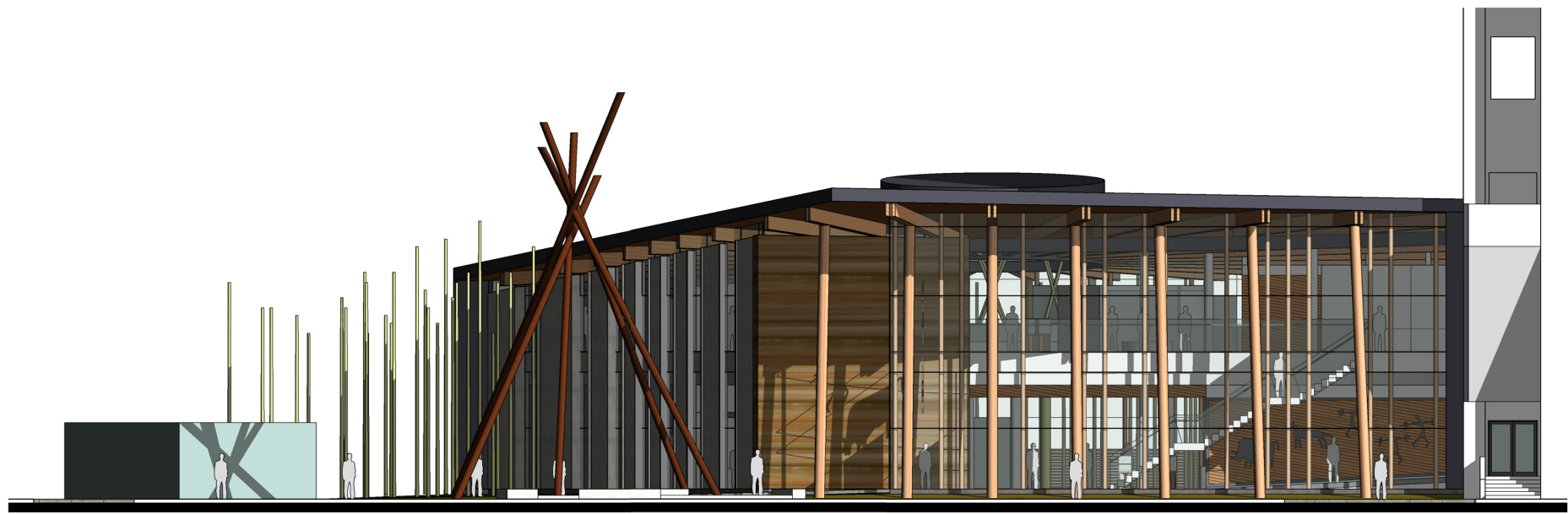

WEST ELEVATION

2.2.5 Sections and Elevations

The heavy timber sloped roof structure is a major design element. The roof slope, rising from east to west, adds a sense of energy and dynamic quality to the volumes enclosed below. The radial grid guides the viewer to the Drum at the heart of the Gathering Place. The roof overhang gives a sense of shelter and welcome to visitors. The rammed earth wall serves as a backdrop and provides connection to the earth.

The two-storey volume of the Drum is capped by a sloped roof with clerestory glazing to capture the eastern sun, and a steel support structure that recalls the lacing of the Pow Wow drum. At the two-storey lobby space, a structural “forest” of wood columns and vertical wood members at the glazed wall both define and “blur” the transition from inside to outdoor.

Floor construction is cast-in-place concrete. An access floor system at the second level conceals HVAC systems and permits level access to the roof terrace. Tie-in to the generous floor-to-floor height of the existing Education Building results a ceiling height of approximately 4.3m or 14 feet within the Great Hall.

Exterior finishes include rammed earth, textured precast concrete panels and clear glazing. Heavy timber roof and columns are left exposed with a clear finish. The roof and east facade are finished in prefinished metal cladding with the appearance of zinc.

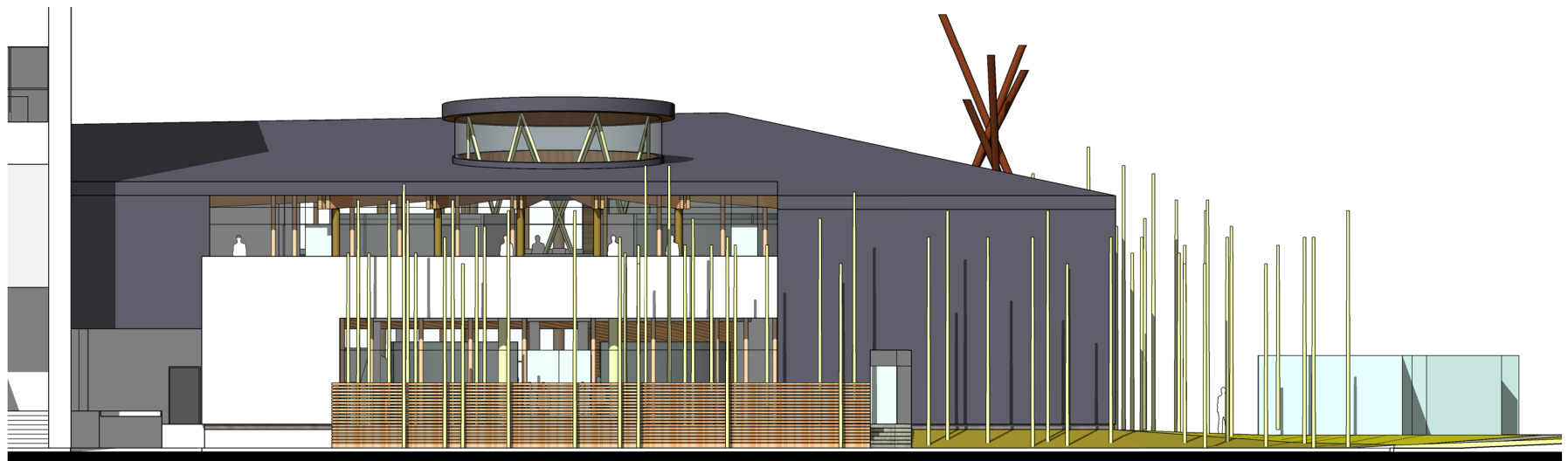

EAST ELEVATION

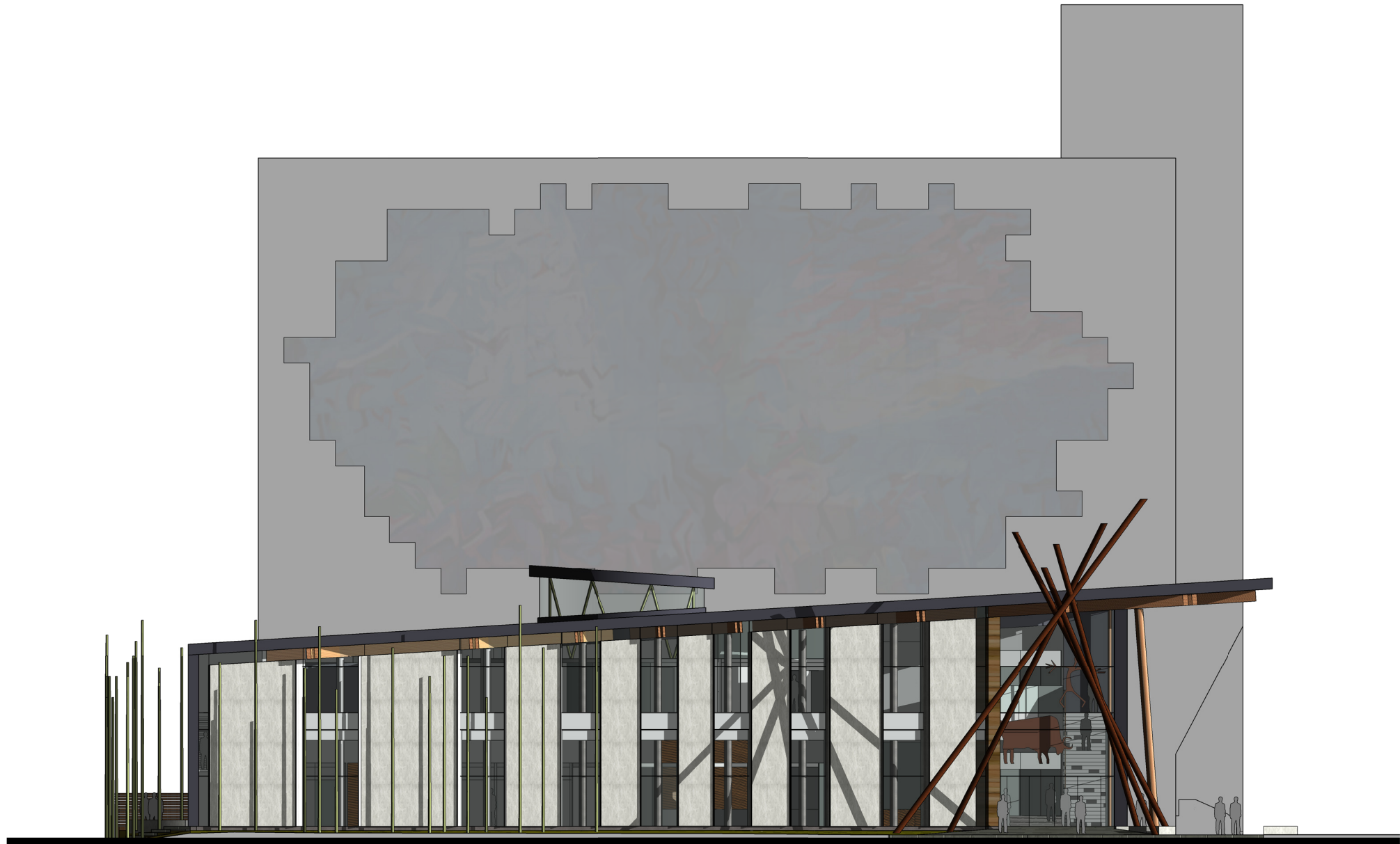

NORTH ELEVATION

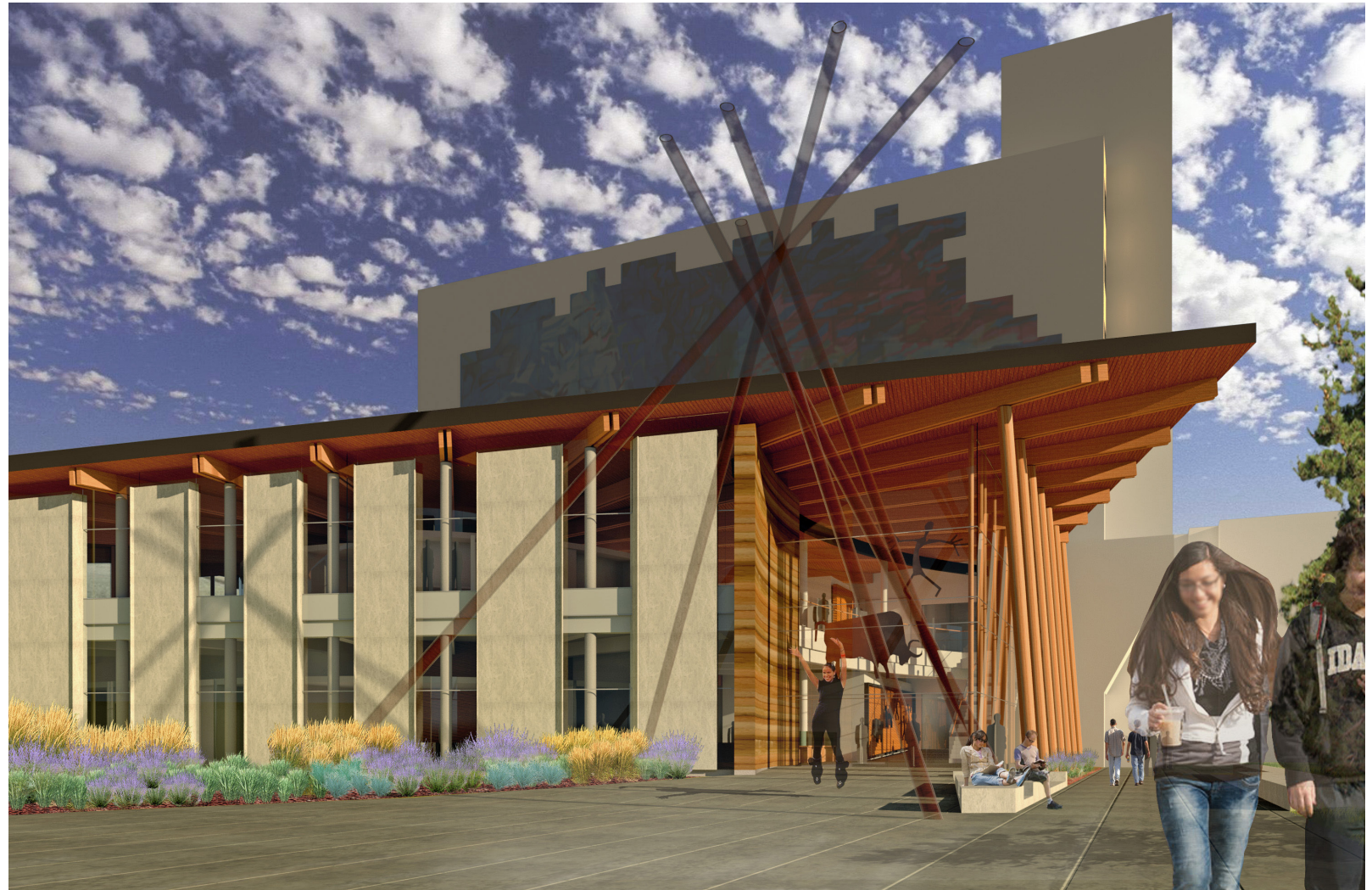



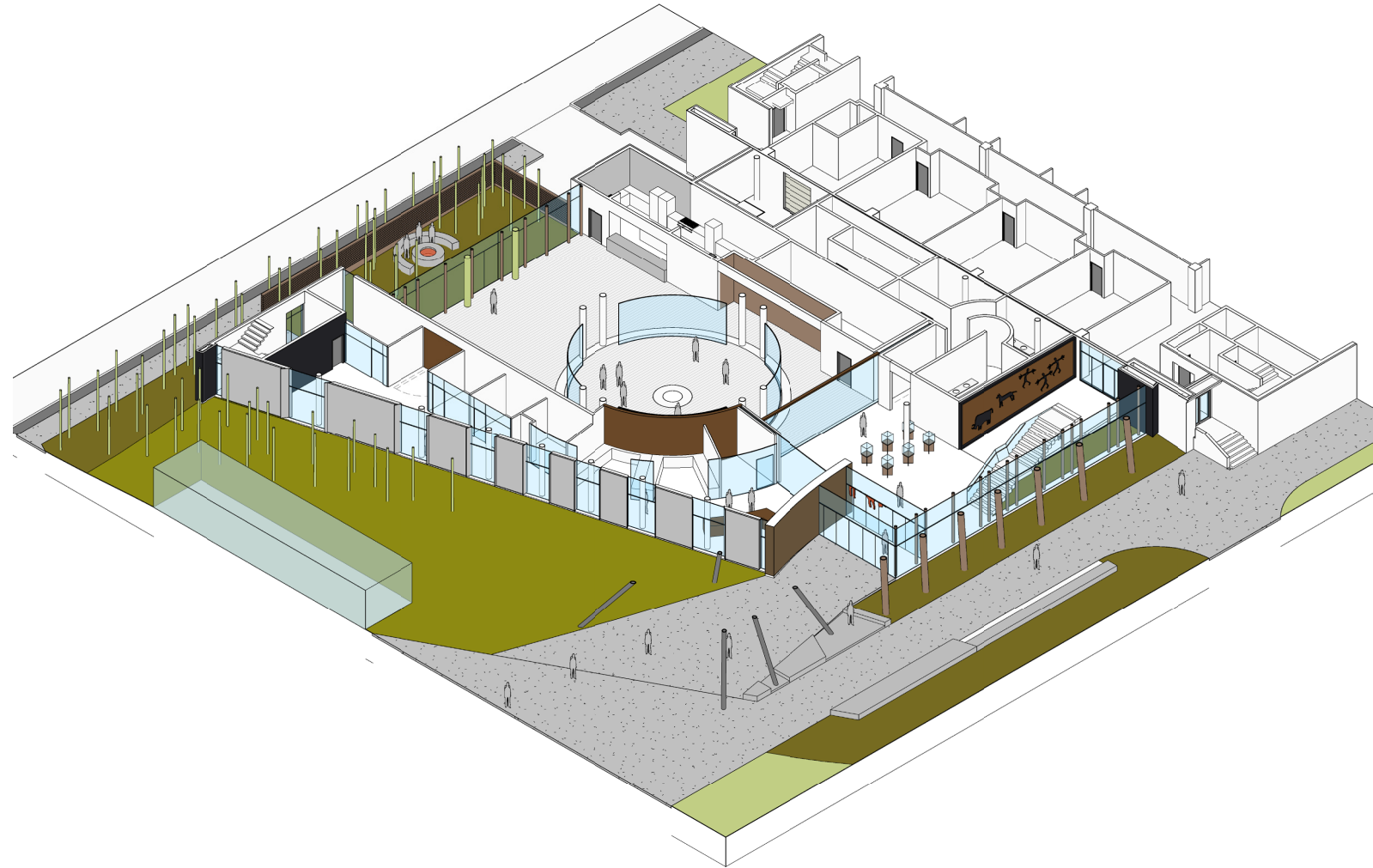

ISOMETRIC NORTHWEST - LEVEL 1

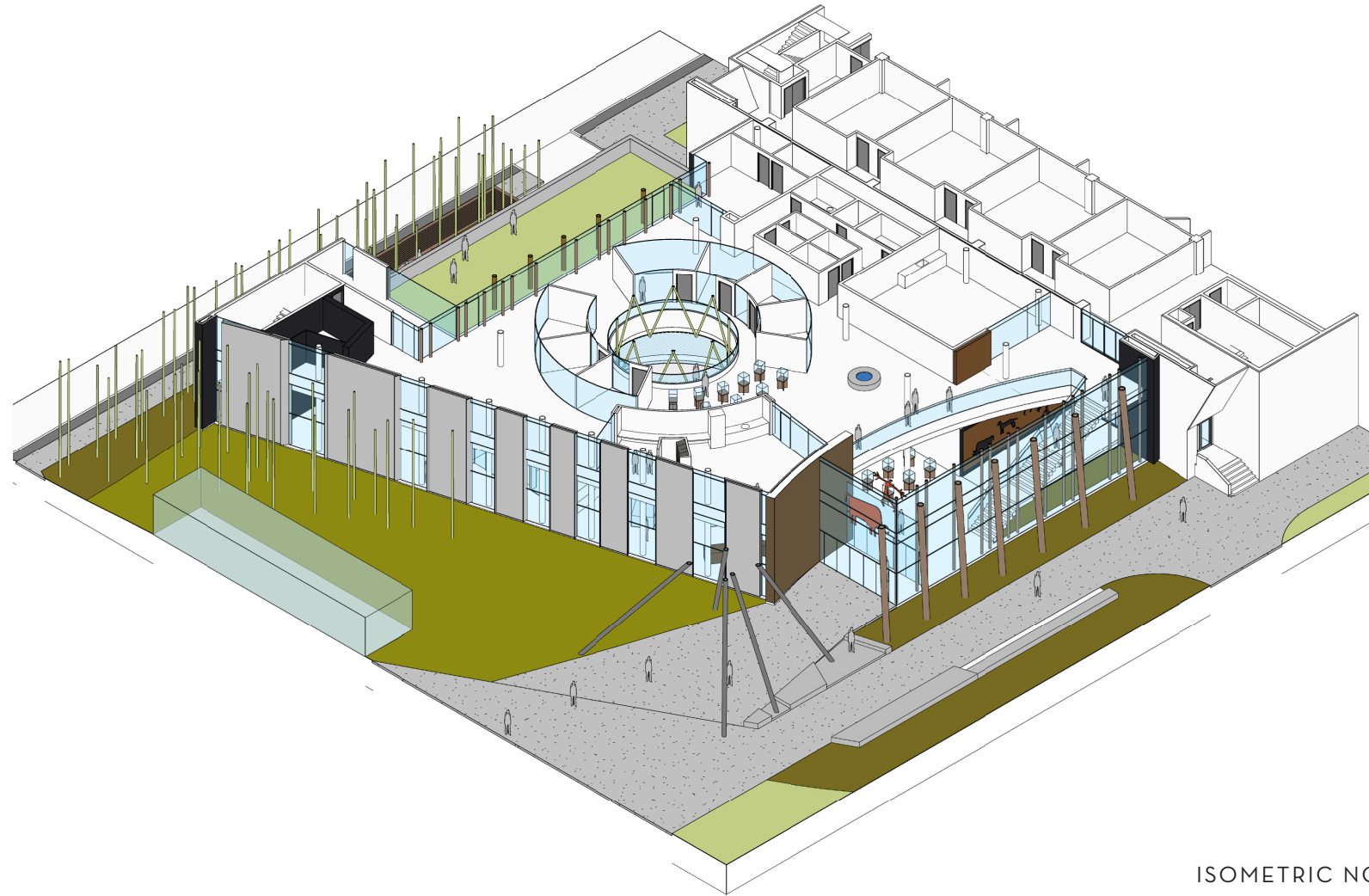

ISOMETRIC NORTHWEST - LEVEL 2

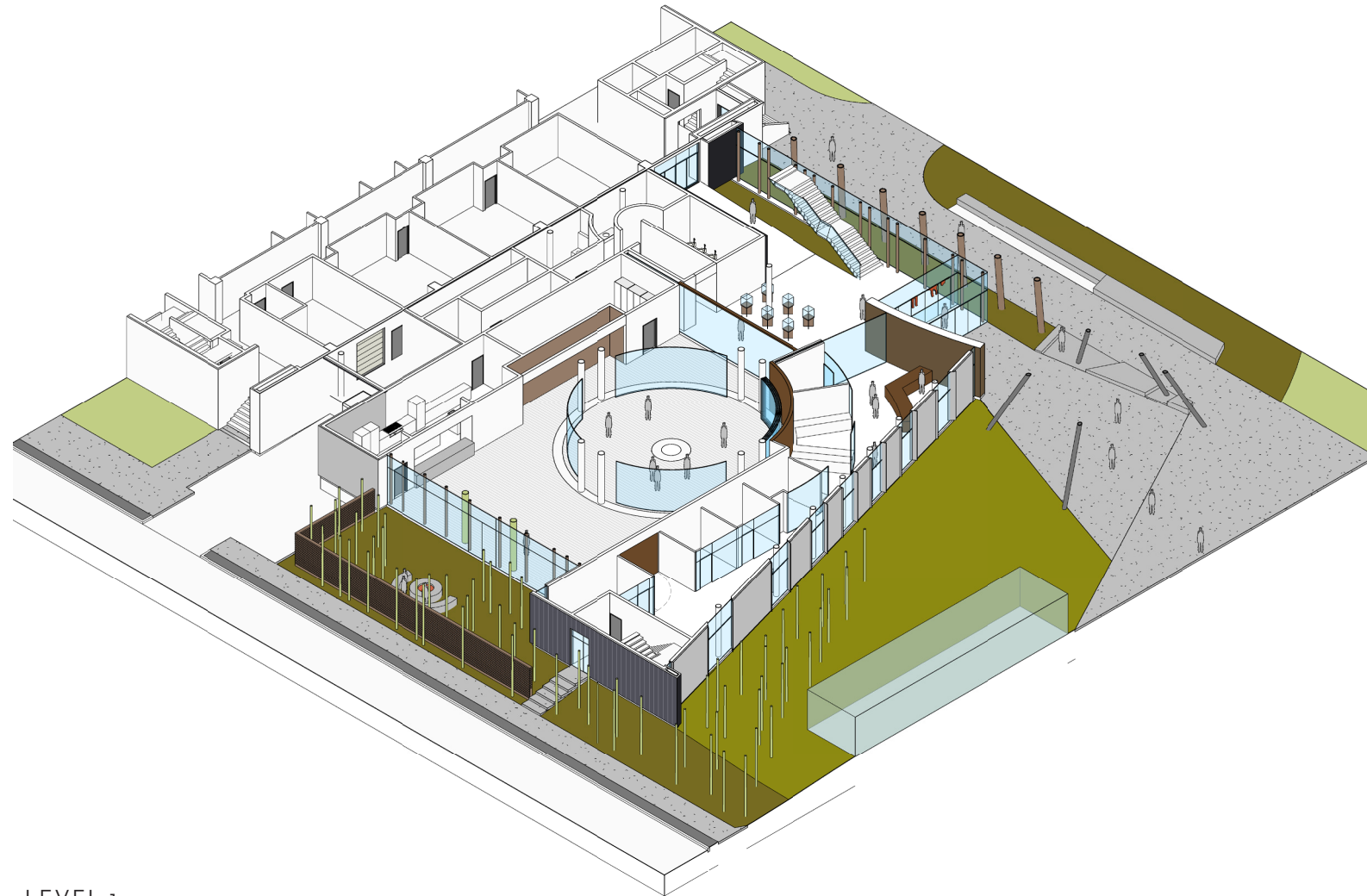

ISOMETRIC NORTHEAST - LEVEL 1

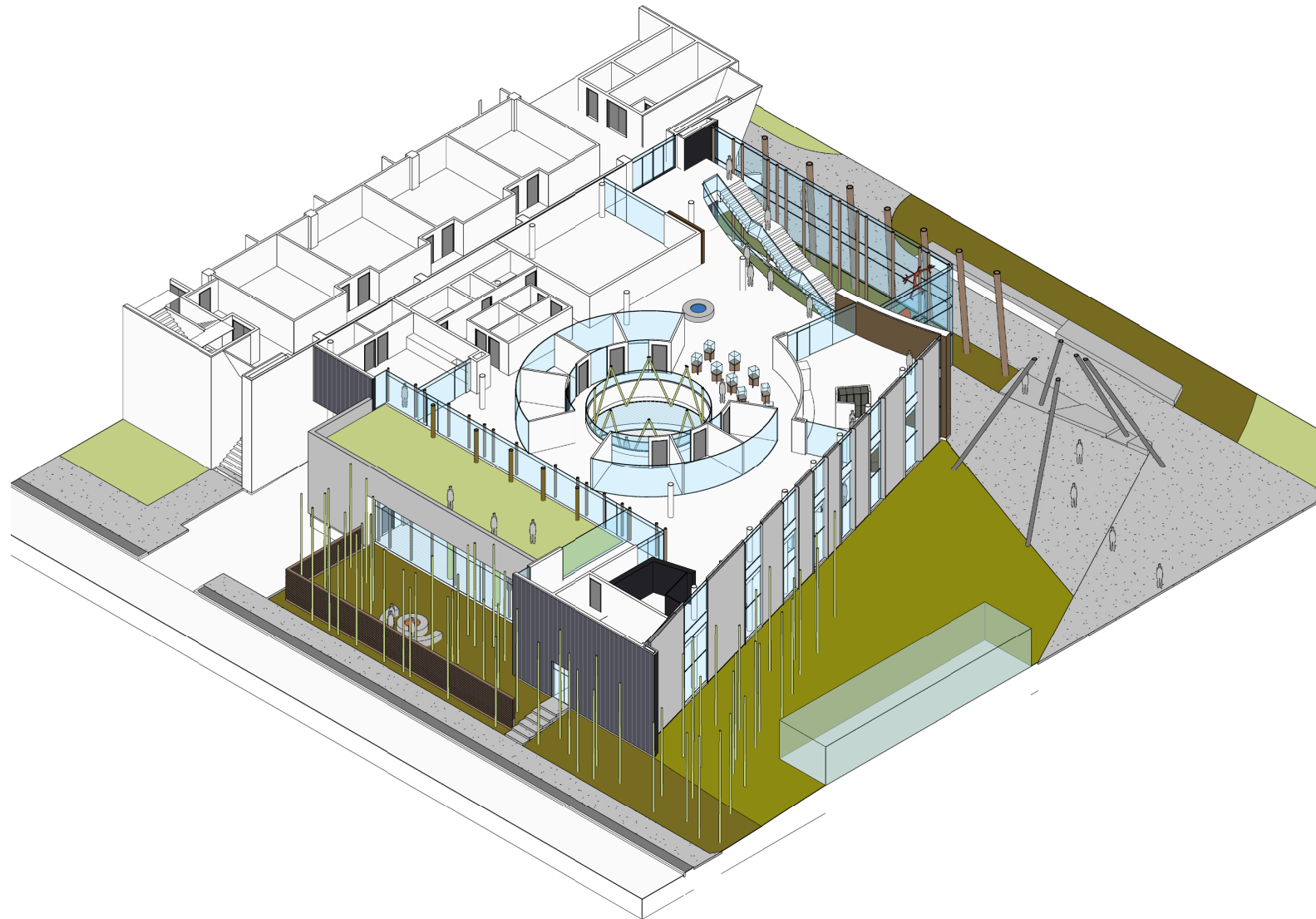

ISOMETRIC NORTHEAST - LEVEL 2

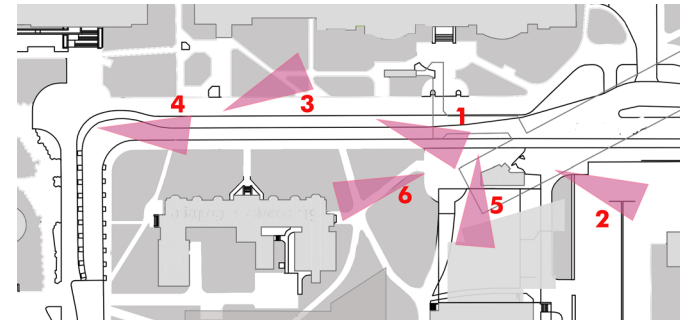

1 LRT ENTRANCE TO UNIVERSITY STATION



2 OLD ST STEPHEN'S COLLEGE



3 DENTISTRY PHARMACY



4 89 AVENUE TRANSIT LOOP + PEDESTRIAN CORRIDOR



5 MURAL AT EDUCATION NORTH



6 ST. JOSEPH'S COLLEGE

2.3 SITE DESIGN

2.3.1 Planning Objectives

The Gathering Place site is located in the heart of the North Campus, immediately north of the Education Building and fronting the 89th Avenue pedestrian pathway transit loop and LRT connection. This prominent location will give aboriginal culture a strong presence on campus, and provide opportunities for connection and interaction between aboriginal and non-aboriginal students, faculty and the wider population.

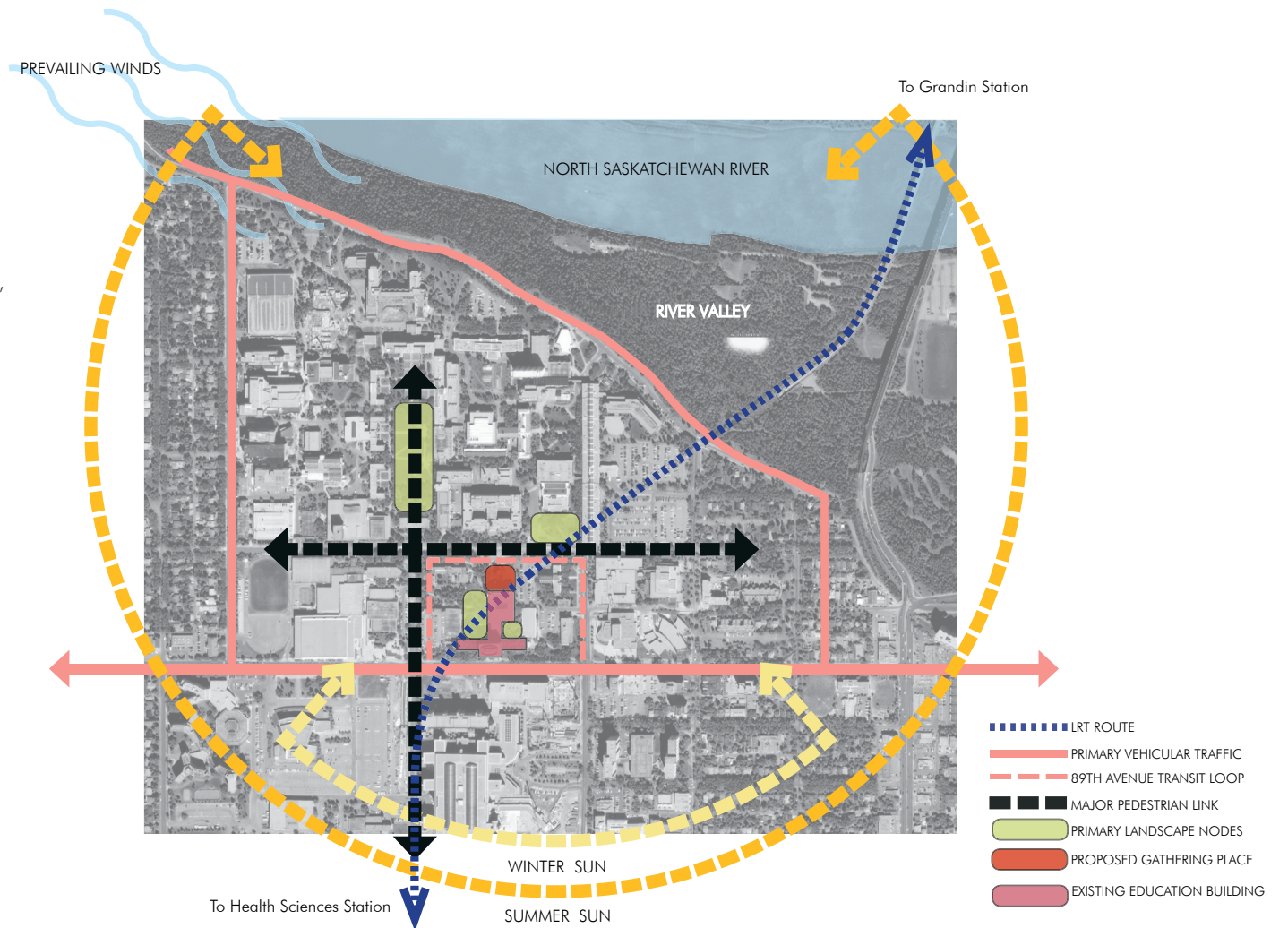

CONTEXT

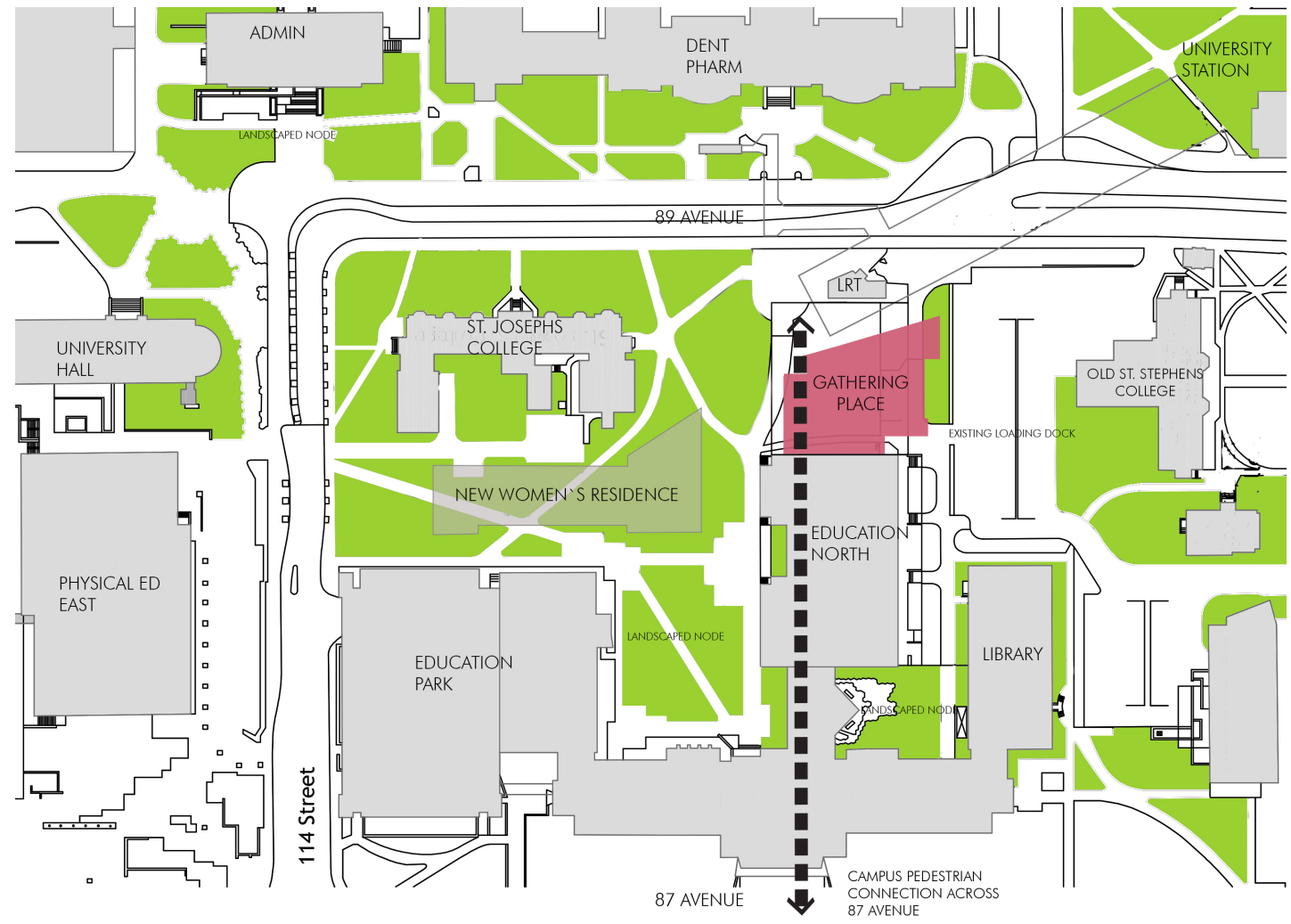

SITE ANALYSIS

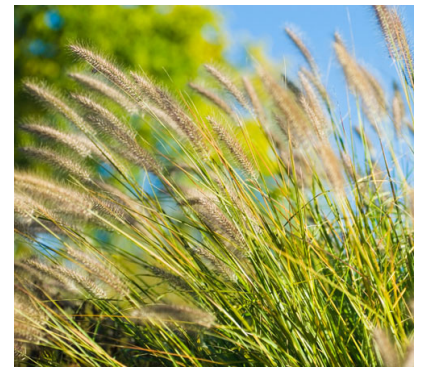



2.3.4 Landscape

Landscaping for the Gathering Place site is intended to create a natural setting evocative of forest and meadows. Mass plantings will include native species including trembling aspen, grasses, sages and ground cover. Development of an entrance plaza will provide an opportunity to extend the visual footprint of the Gathering Place and provide a transition from the overall campus grounds to the building.

The site is adjacent to the landscaped area between the Education Building and St' Joseph's College, a primary landscaping node on campus. New landscaping will tie into and overlap this area, with the intent to create a "meadow" to the west that will allow more daylight into the building and add depth of field for views from within the lobby space. An aspen "forest" will be introduced to the east as an extension of the Great Hall space and also as a buffer to the parking lot. Tall grasses to the north give definition to frontage on 89th Avenue, and act as a buffer to the LRT entrance.

A second level terrace provides another connection to the aspen forest, with potential as garden space for herbs and plants used in traditional medicine and cooking.

The landscape design will be further developed at the design development stage with particular attention to plant species, pedestrian pathways and gathering areas. Development of landscaping by St. Joseph's College will require consultation with adjacent property holder.

89 AVENUE

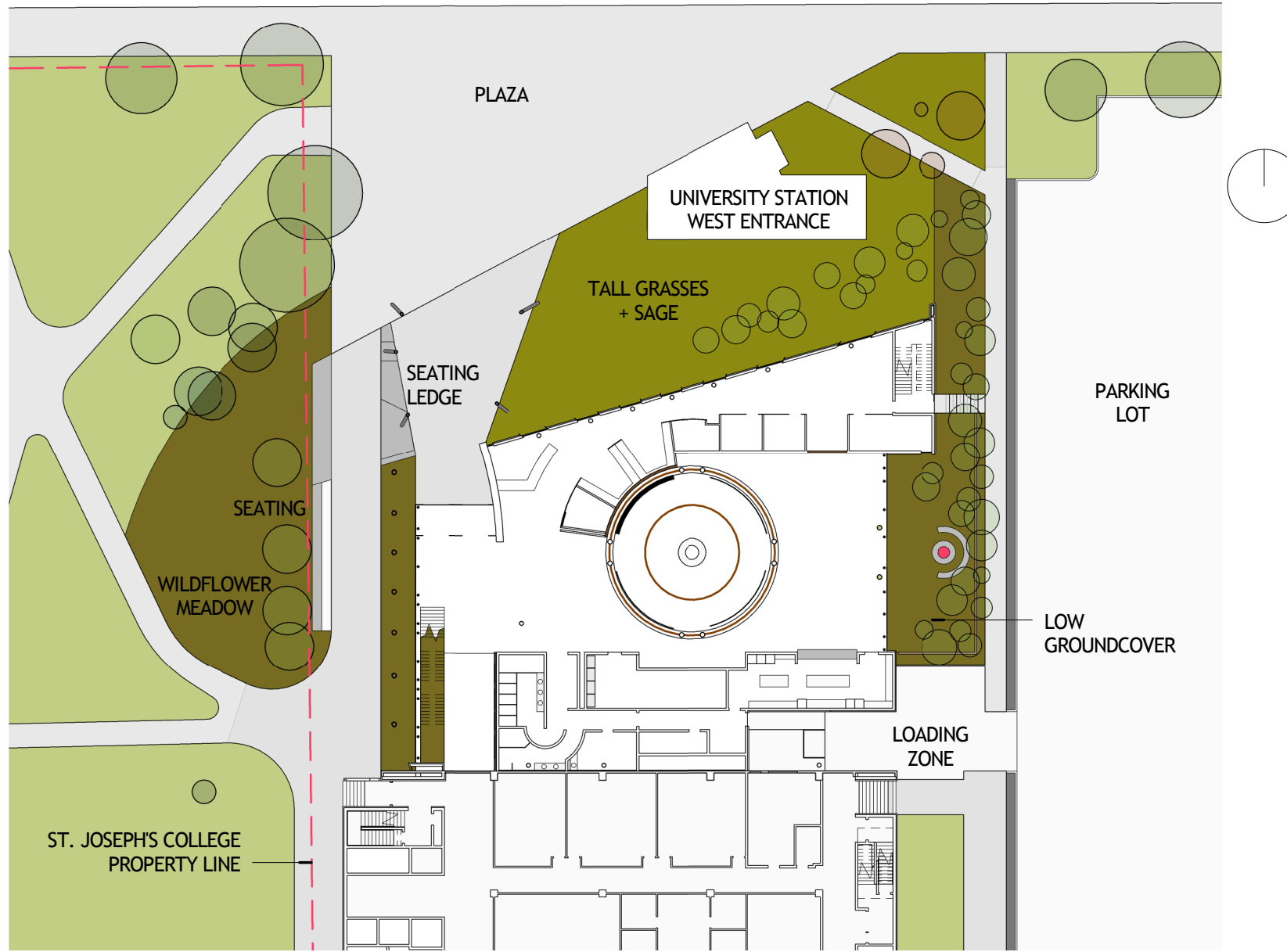

SITE PLAN AT GRADE

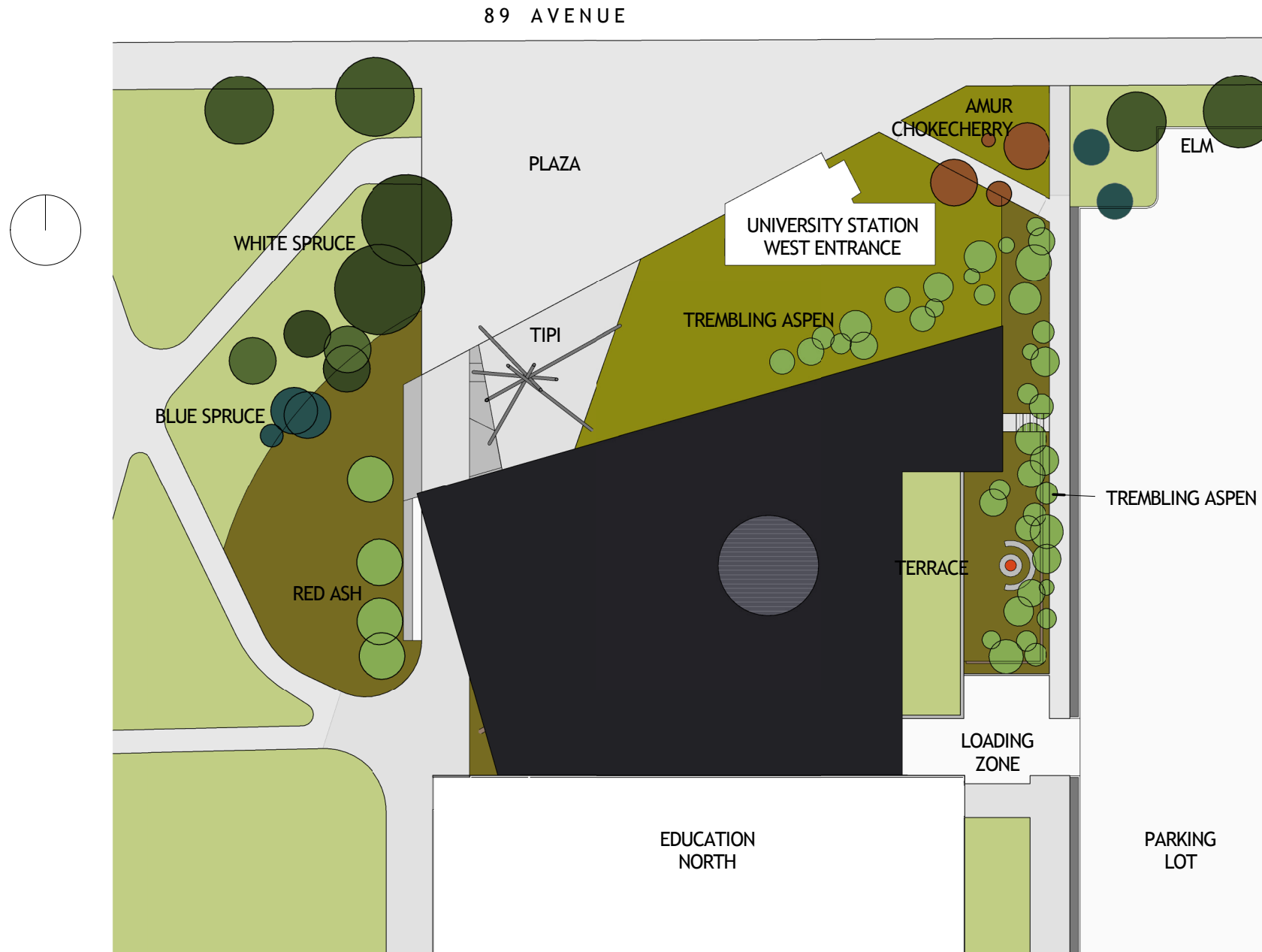

SITE PLAN AT ROOF

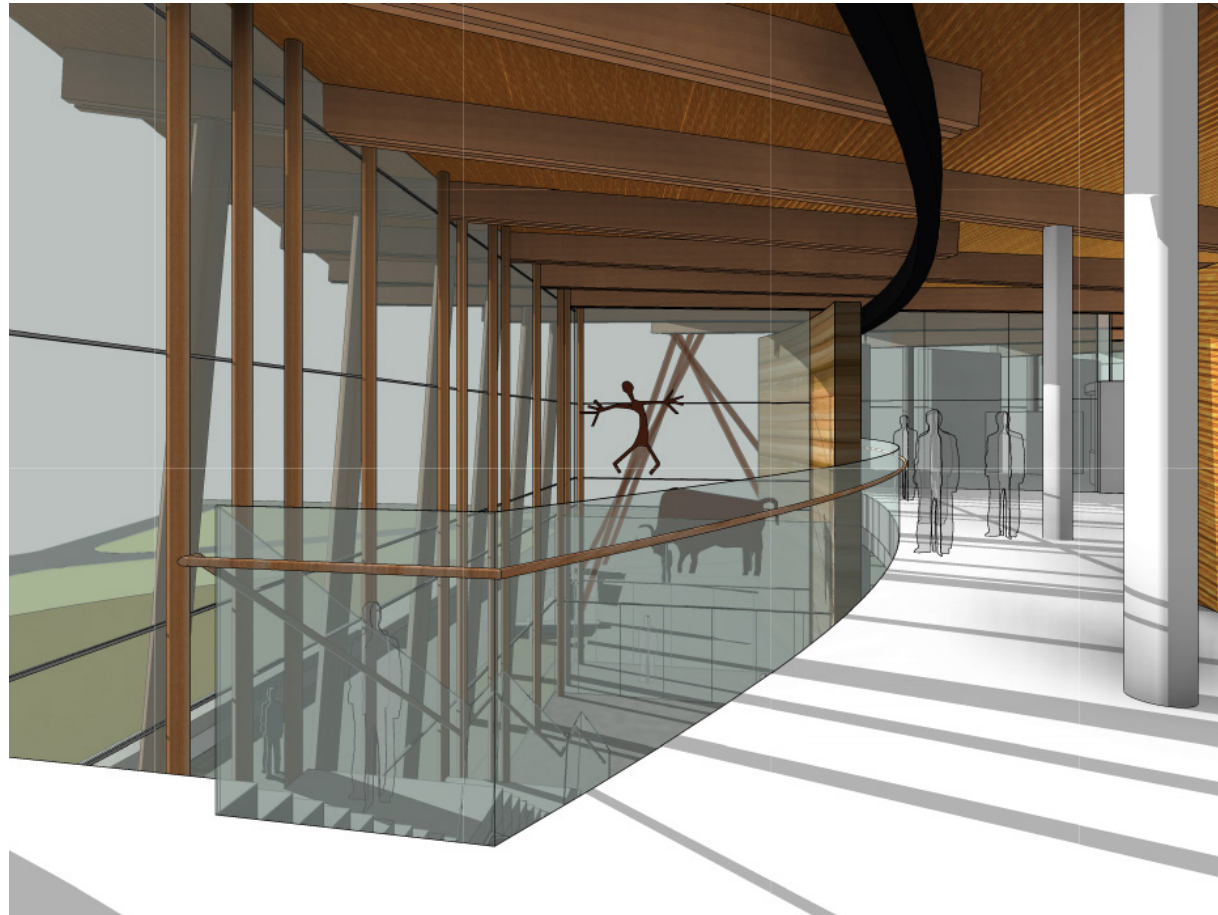

LEVEL TWO LOBBY

2.4 INTERIOR DESIGN

Interior spaces are designed to look inwards to the central Drum, or outwards to the surrounding landscaping, pathways and campus. The Great Hall is adaptable to host a variety of functions and events, and through the use of sliding screens and partitions can be opened up to connect to adjacent areas or closed off for privacy.

The majority of Knowledge Commons space is provided at the second floor. Access to this student space is compressed, with pedestrian flow from the Education Building directed down the open stair.

Materials and finishes are selected to express warmth, comfort and nature. Clear finished glue laminated wood beams and solid wood decking form the components of the exposed roof structure. Supporting columns include both clear finish glue laminated timber and smooth finish concrete. Flooring at public circulation areas and washrooms is porcelain/stone tile, with carpet tile at the second floor student/staff areas. Flooring for the Great Hall will be clear finish sprung hardwood to accommodate various activities and performances.

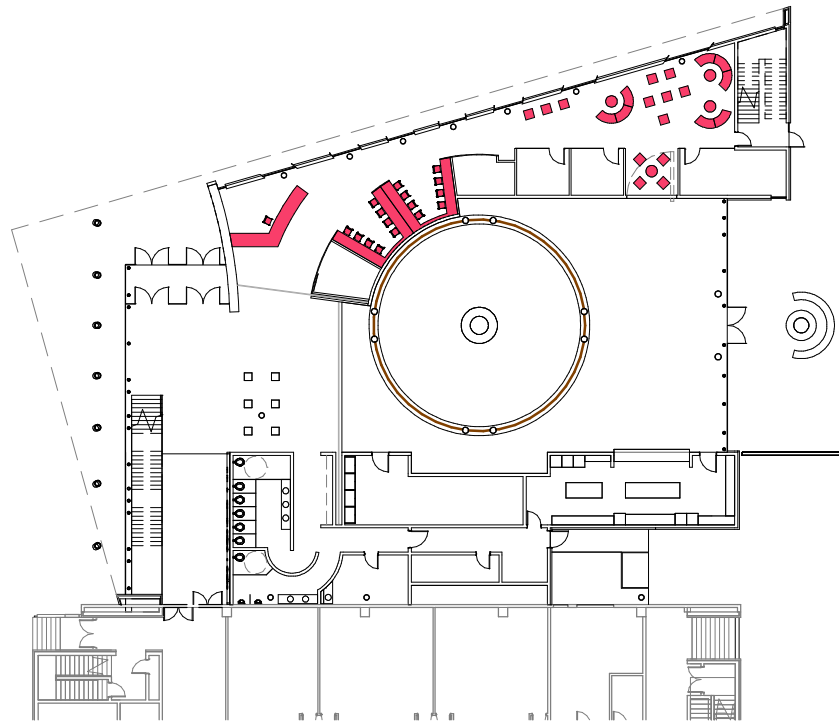

LEVEL ONE - KNOWLEDGE COMMONS SEATING

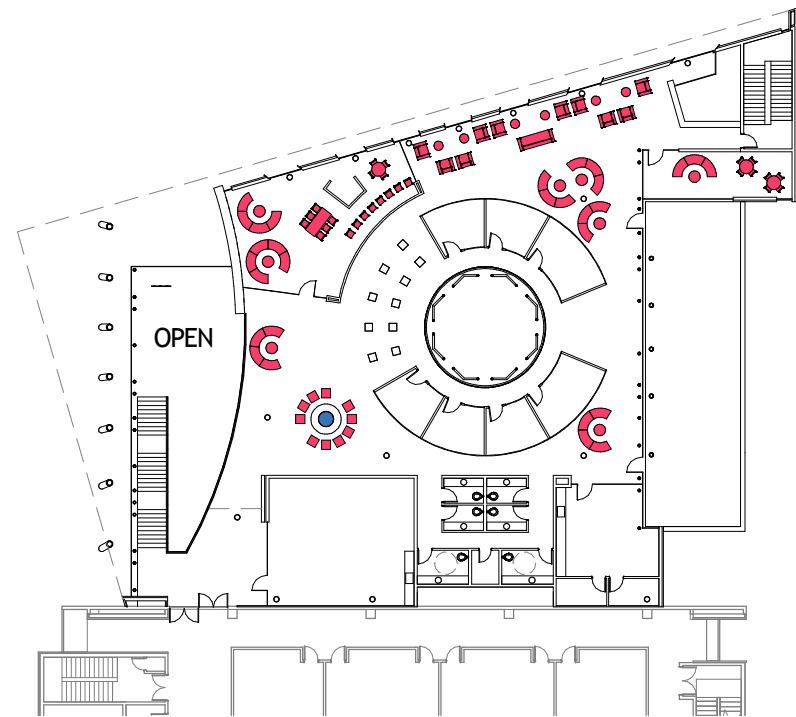

LEVEL TWO - KNOWLEDGE COMMONS SEATING

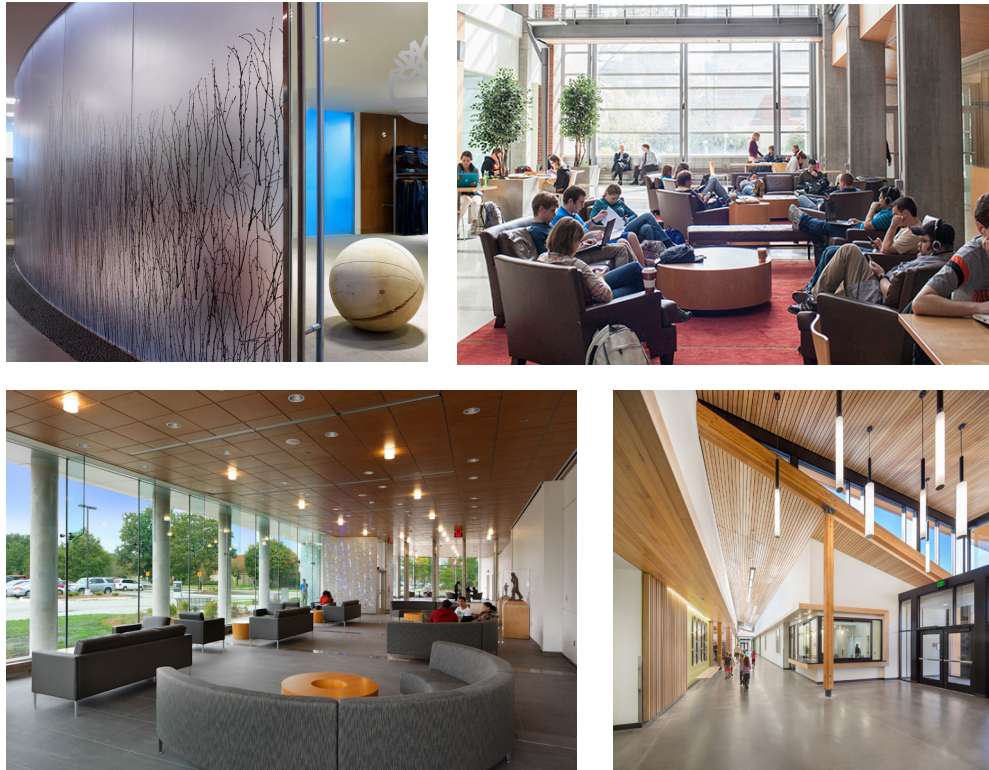

Walls are typically steel stud and drywall with painted finish, with some walls blocked in clear finished wood, stone, tile or simply a feature paint colour. Interior glazed walls and sidelights provide daylighting to interior rooms and provide the opportunity for patterning to evoke a forest or grassland setting. Ceilings are a combination of exposed structure and painted drywall. A wood slat ceiling will add pattern, texture and depth to the Great Hall space.

Selected walls used to define spaces are also designed to be feature elements. The rammed earth wall is a major design element and backdrop for the entry, reception area, knowledge commons and TYP room. Other examples are the wall flanking the main corridor that will be used as a backdrop for graphics depicting aboriginal culture, and the Gallery wall within the Great Hall. At the second level a wall serves as a backdrop for the Janvier "Sky Talk" painting.

Wood finishes will be used for built-in millwork for exhibits. Other millwork will consist of solid surface, stainless steel, wood veneer or plastic laminate depending on durability and function.

Interior finishes and materials will be refined in the Design Development phase.

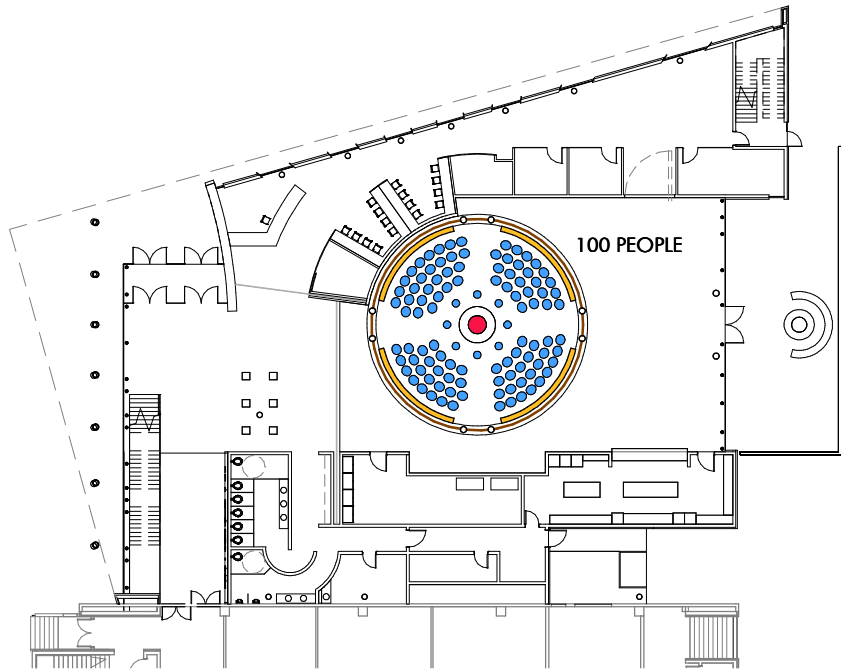

LEVEL ONE - GREAT HALL CEREMONIES

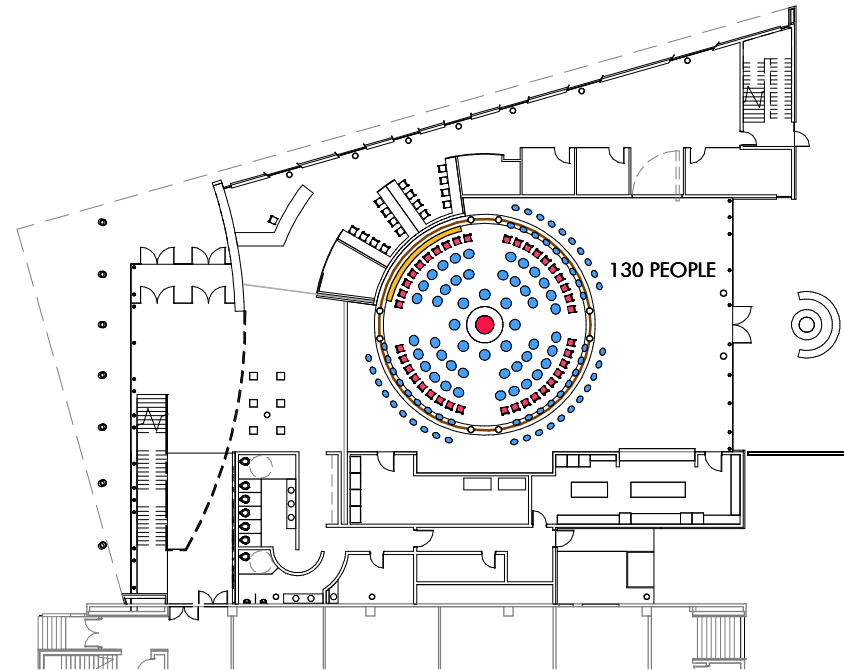

LEVEL ONE - GREAT HALL CEREMONIES

2.4.1 Interior Layouts

Great Hall

The Great Hall is the focal point of the building, the place of gathering. This flexible space will serve a multitude of functions and programs. Various plans have been developed to demonstrate layouts and capacity for events and celebrations such as ceremonies, presentations and lectures, feasts, cultural exhibitions, meetings and instructional classes.

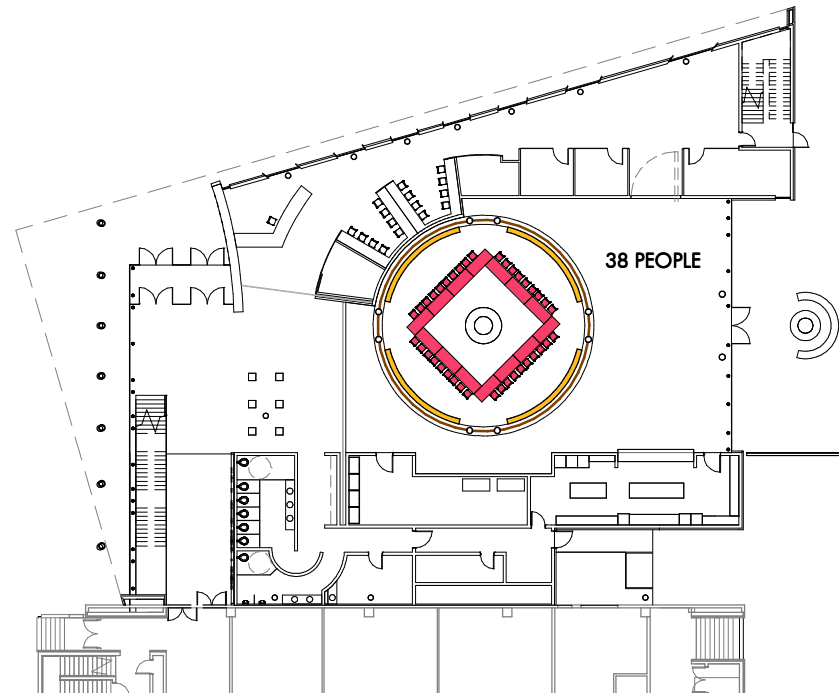

LEVEL ONE - GREAT HALL CAI MEETINGS

CULTURAL

Pipe ceremonies
Teachings
Dance performances/teachings
Fiddling performances/teachings
Throat singers/teachings
Stew and bannock
Elders' tea and bannock
Round dances

EXHIBITS

Art installations
Student art shows

ABORIGINAL STUDENT COUNCIL

Student/family celebrations
Potlucks
Movie nights
Social gathering

CAMPUS AMBASSADORS/RO

Start of the tour

ACADEMIC

Faculty lectures
Faculty events
Artist in residence

MEETING SPACE

Aboriginal focus group
Council on aboriginal initiatives
Open space for study groups

COMMUNITY TEACH-INS/ALL FACULTIES

Faculty speaker series
Demonstration walks
Screenings of documentaries
TRC continued conversations
Traditional cooking demonstrations

GATHERINGS

ASSC spring convocation gathering
TAWOW/orientation
President functions
Town halls

COMMUNITY OUTREACH

Shell luncheons
Aboriginal career mixer
Aboriginal student discovery day
Rupert's Land institute funding sessions
Braided journeys program
U-school

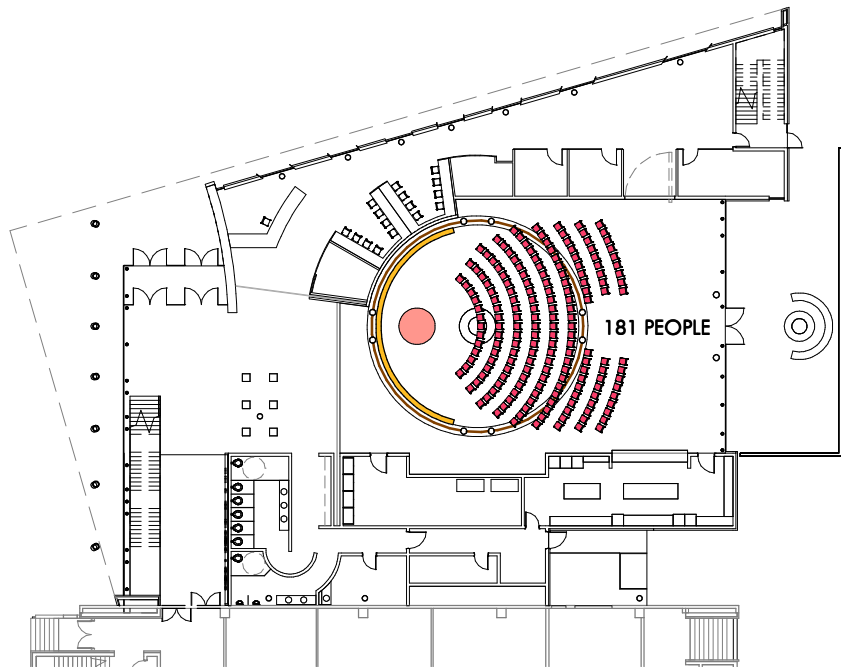

LEVEL ONE - GREAT HALL PRESENTATIONS

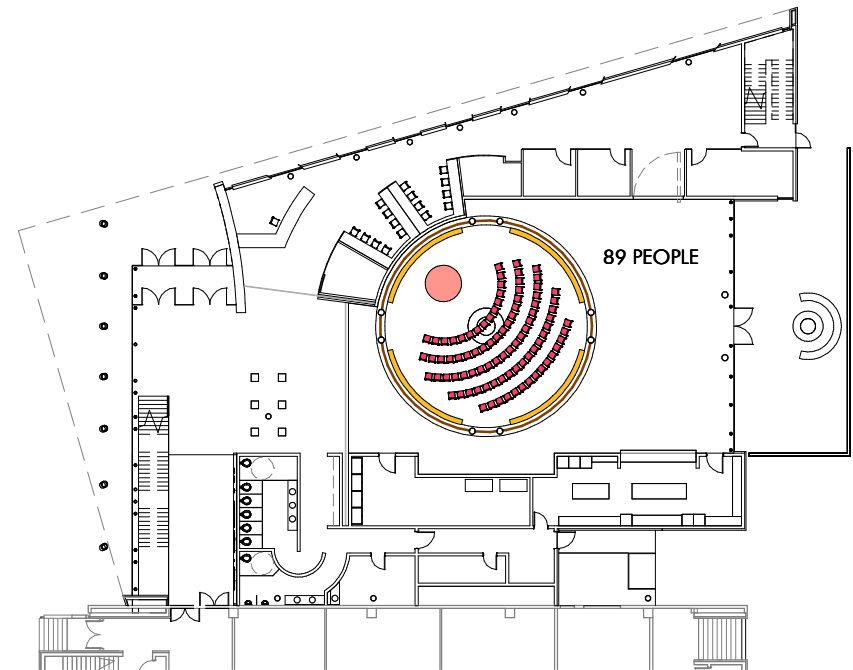

LEVEL ONE - GREAT HALL PRESENTATIONS

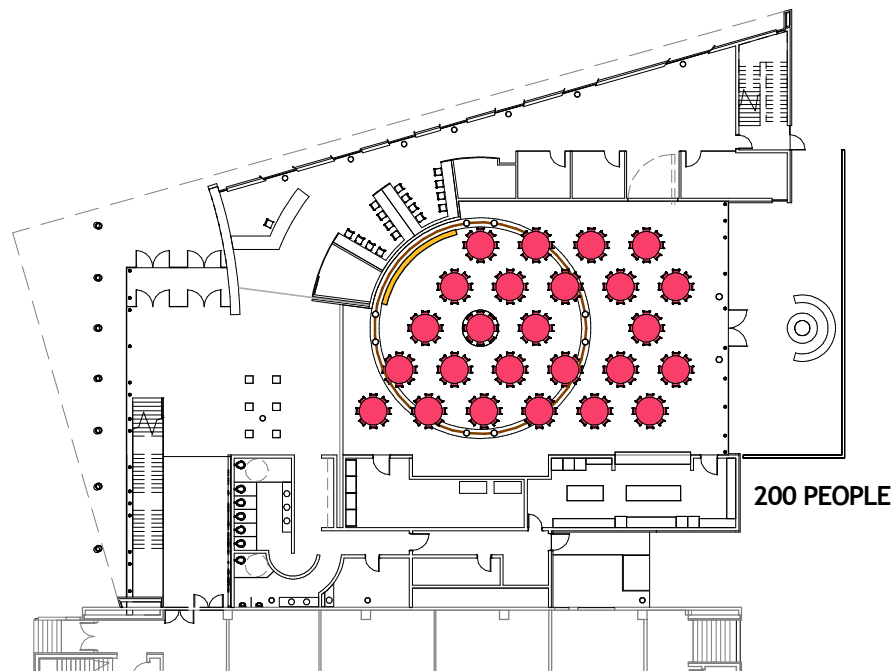

LEVEL ONE - GREAT HALL FEASTS

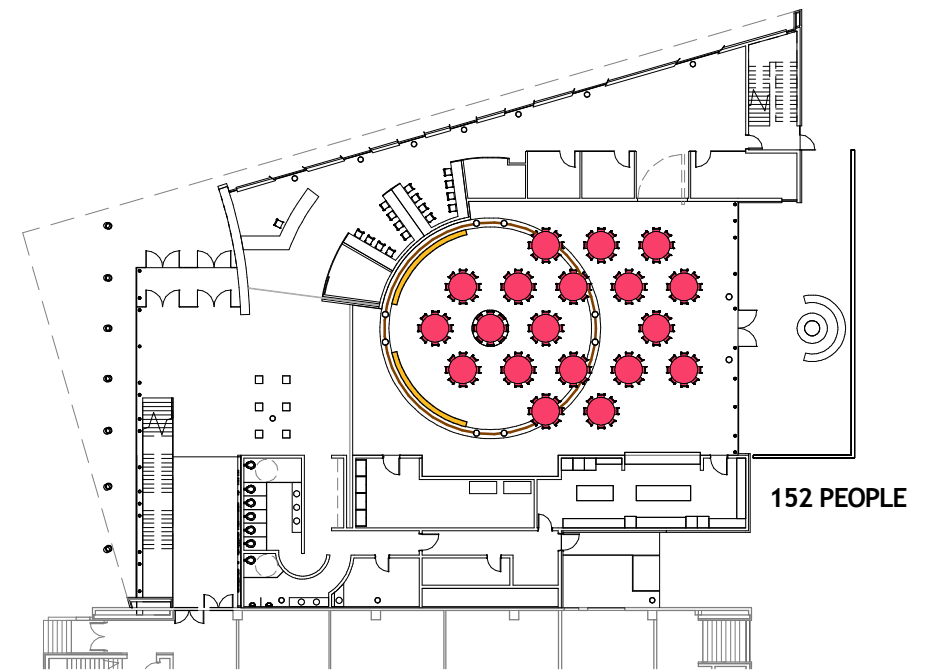

LEVEL ONE - GREAT HALL FEASTS

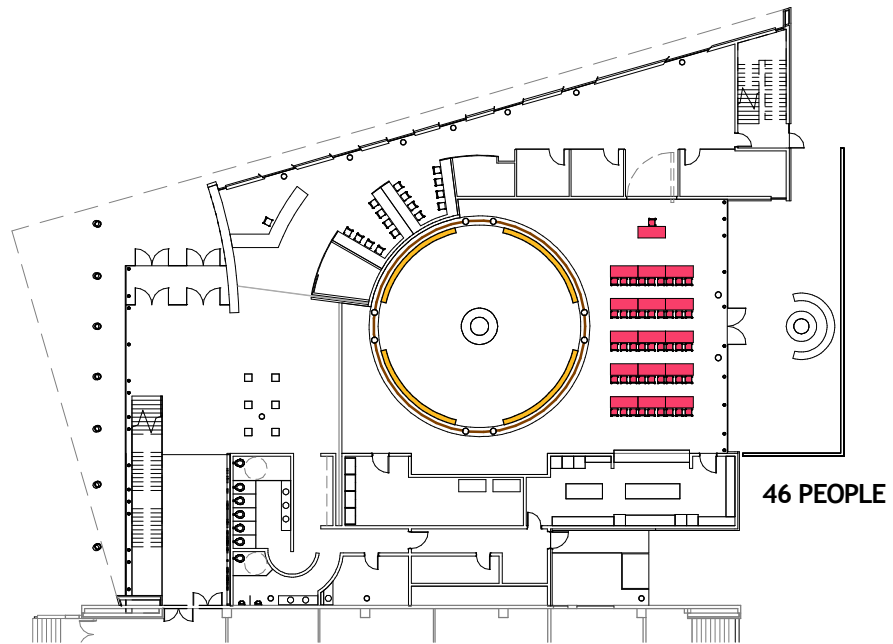

46 PEOPLE

LEVEL ONE - CLASSROOM

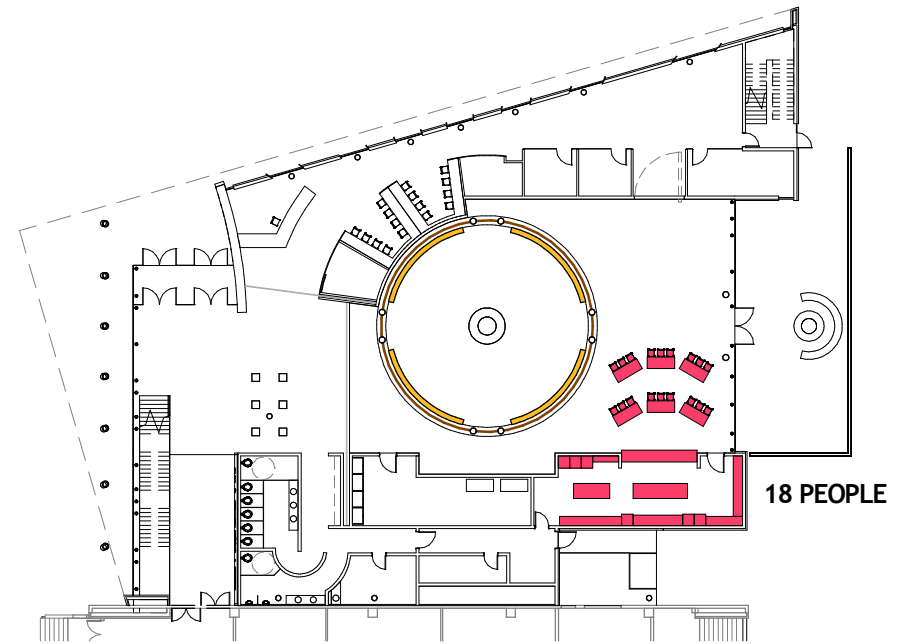

18 PEOPLE

LEVEL ONE - COOKING CLASSES

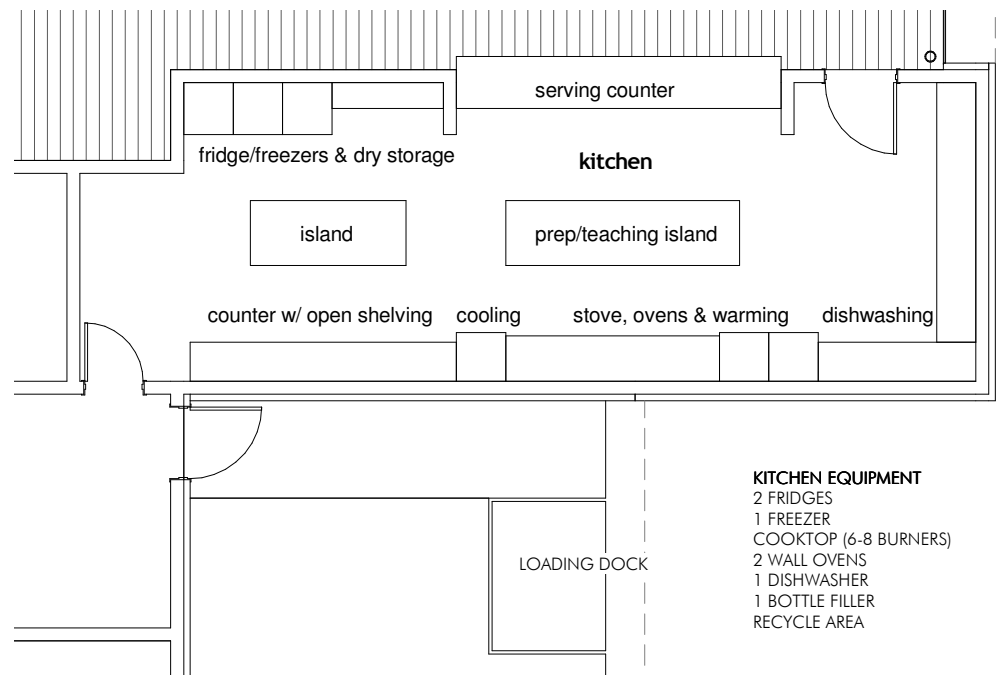

- KITCHEN EQUIPMENT**
 2 FRIDGES
 1 FREEZER
 COOKTOP (6-8 BURNERS)
 2 WALL OVENS
 1 DISHWASHER
 1 BOTTLE FILLER
 RECYCLE AREA

KITCHEN PLAN



SAN FRANCISCO COOKING SCHOOL

In order to provide a proper teaching kitchen as well as support for functions within the Great Hall, a full commercial kitchen is proposed. This preliminary layout shows that the space is adequate in size to accommodate the required equipment. Proximity to the Loading Dock area is convenient for deliveries and waste removal. During the Design Development Phase a kitchen design consultant will provide expertise in finalizing the layout and details.



2.5 CULTURAL IDENTITY

A primary driver for the cultural identity of the Gathering Place is the geographical location within the Plains Cree territory shared with the Métis for centuries. It is important for the building to have a presence that identifies it as a place of welcome and cultural connection.

Also significant is to honour and celebrate diversity with welcoming gestures to all First Nations, Métis and Inuit students.

Tipi

The tipi was used as a dwelling by the nomadic tribes of the region and as a cultural symbol, there is nothing more recognizable. The oversized tipi structure marks the entrance to the Gathering Place and provides a distinctive cultural identity for the building.

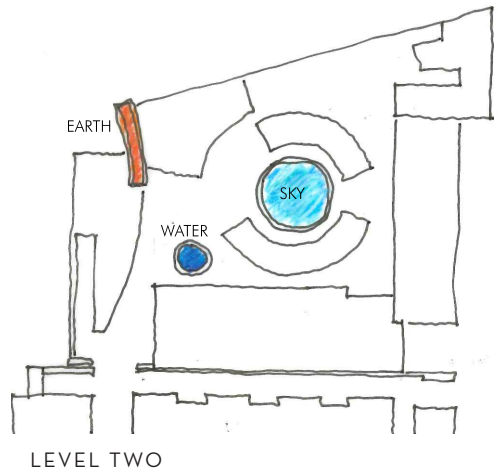

QULLIQ

Elements

The fire feature on the exterior and to the east of the great hall on axis with the centre of the ceremonial circle is balanced by a water feature on the second floor. The elements, of fire and water play important roles in many stories, myths, beliefs and memories. The presence of fire is central to many Aboriginal ceremonies and has played a key role in survival. Fire creates an atmosphere of warmth and welcoming while the sound of water helps to create an atmosphere of calm. These features also provide opportunities for small groups to gather around and enjoy.

Petroglyphs

Petroglyphs were used by First Nations people of this region who were proud of their heritage, expressive and creative and wanted to share their legacy. These carvings and paintings were an early form of communication used to record important events such as hunts, significant life experiences and battles. The symbols shown in the renderings, such as the bison, are representations only. During Design Development, a comprehensive study and selection process will take place.

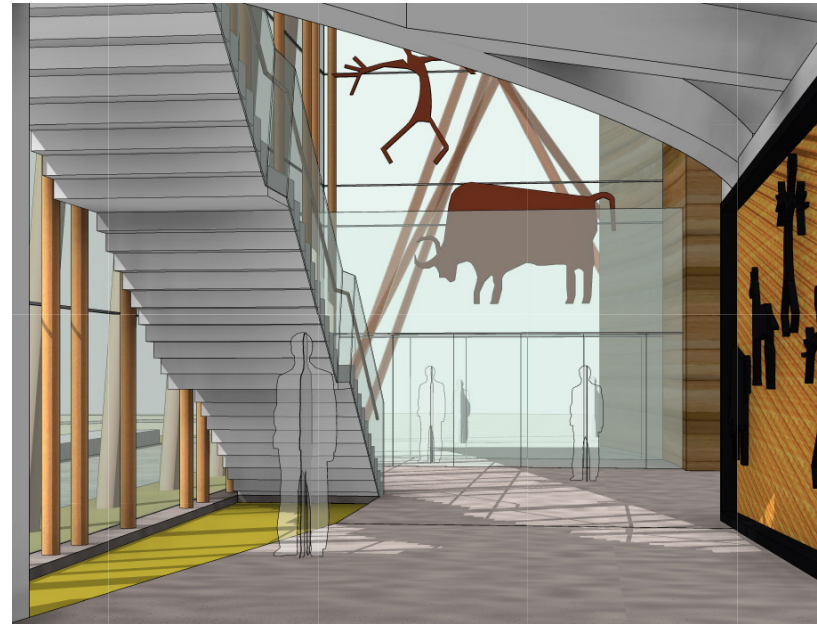

LOBBY LOOKING NORTH

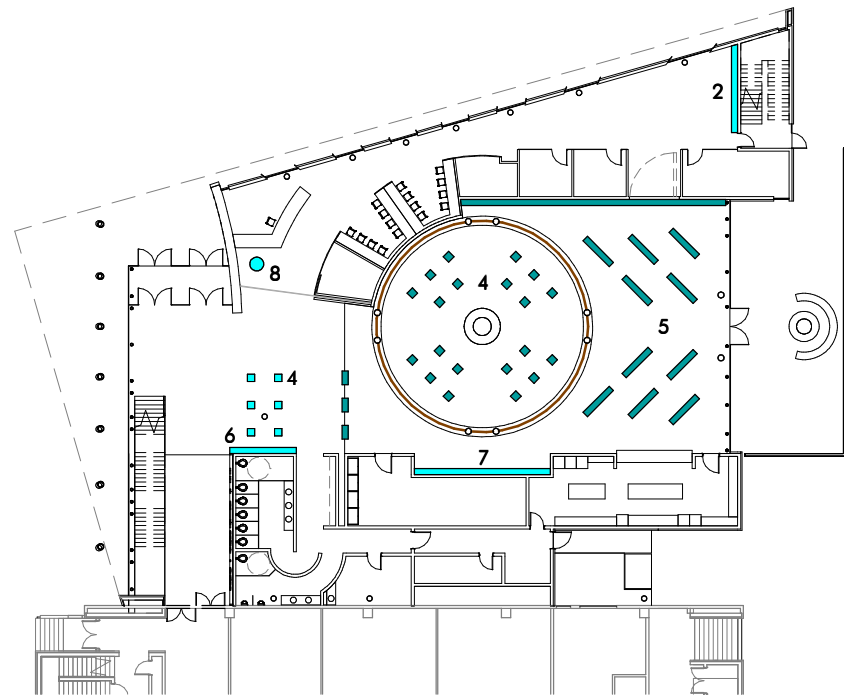

LEVEL ONE - EXHIBIT

1. JANVIER 'SKY TALK'
2. DISPLAY WALL
3. TRC DISPLAY WALL
4. MOVABLE DISPLAY BOXES
5. MOVABLE DISPLAY PANELS
6. DONOR WALL
7. GALLERY WALL
8. SCULPTURE

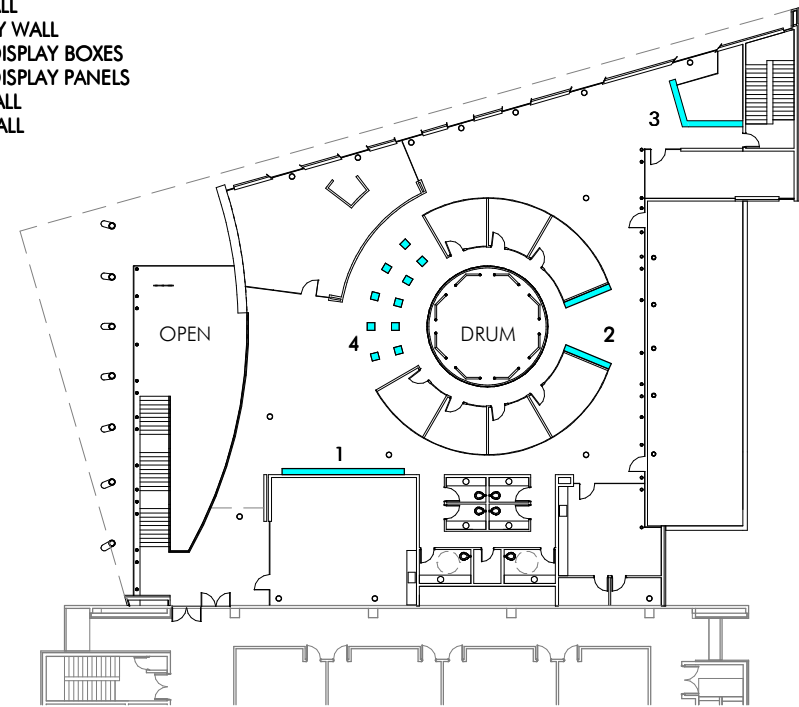

LEVEL TWO - EXHIBIT

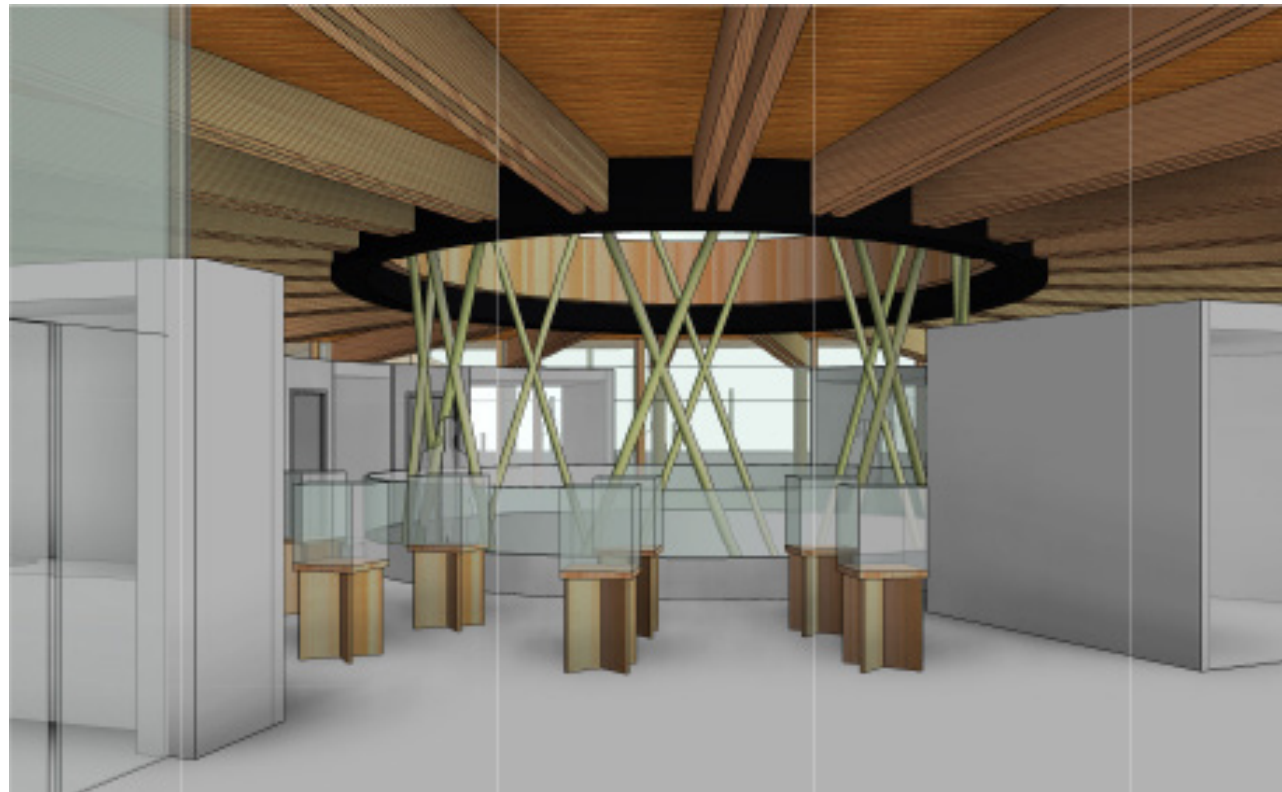

LEVEL TWO KNOWLEDGE COMMONS

Cultural Exhibition

There are a number of spaces throughout the Gathering Place where the opportunity exists to showcase traditional and modern aboriginal art, crafts and artifacts for the general campus population and visitors to appreciate. The Gallery and Exhibit space identified is not necessarily intended as a static exhibition but could house a changing display of items held in the University of Alberta collections.

3.0 REGULATORY ANALYSIS

3.1 BUILDING CODE REVIEW

Preliminary consultation with regulatory authorities was done to determine the best approach to categorize the building. For the purposes of building code requirements, the Gathering Place will be designed as a fully sprinklered, two-storey addition to the existing non-sprinklered, seven-storey Education Building. Existing and new construction will be divided by a rated fire separation.

The following code review is based on the 2006 edition of the Alberta Building Code.

BUILDING AREA - ADDITION
1227m² main floor footprint

MAJOR OCCUPANCY CLASSIFICATION
Group A, Division 2, Assembly Occupancy

BUILDING CLASSIFICATION
3.2.2.23 Group A2, Any Height, Any Area, Sprinklered.
Non-combustible construction.
2 hour rated fire separation required at floor assemblies and supporting structure.
No rating required at roof assemblies and supporting structure.

HEAVY TIMBER CONSTRUCTION

3.2.2.16 Heavy timber roof permitted in buildings up to 2 storeys and sprinklered.

TRAVEL DISTANCE TO EXIT

3.4.2.5.1 Maximum travel distance to nearest exit shall not exceed 45m in floor area sprinklered throughout.

BARRIER FREE REQUIREMENTS

The main entrance, student and staff areas throughout the main and second floor will meet barrier free requirements. Washrooms at both levels will also meet barrier free requirements.

HEALTH REQUIREMENTS

Kitchen facilities will be designed to meet Alberta Health requirements.

4.0 SUSTAINABLE STRATEGIES

First Nations people have a profound spiritual connection to Mother Earth. It is understood that we should use great care to take only what is needed in order to respect the existence of future generations. It is important that this project provides for the specific functional needs within the built environment without compromising the integrity of our surroundings for future generations.

Construction and operation of buildings consumes more energy and emits more greenhouse gasses than any other sector. The design of a sustainable building carefully considers the building orientation, day lighting, passive ventilation, energy efficient building systems and materials selection.

Green Globes is an online green building rating and certification tool that the University of Alberta is utilizing for many new and under construction facilities on campus. The Gathering Place will target 4 Green Globes out of 5 indicating leadership in energy and environmental design practices.

The Gathering Place is situated to take advantage of daylighting and to encourage natural ventilation while large overhangs protect against damage from the elements. As an addition to the Education building, there is an opportunity to take advantage of existing utility infrastructure.

Direct access and views to the exterior landscape are key in connecting the interior spaces to the environment. As the seasons are a fundamental part of the connection to the Earth and natural rhythms, reading the seasonal variations plays an important role.

The selection of finish materials that are low in volatile organic compounds (VOCs) can improve occupant health and well-being. As a public facility, there are also practical concerns that require selection of durable materials - long lasting finishes are replaced less often resulting in reduced waste.

It is intended that natural, drought tolerant landscaping is utilized for the site surrounding the Gathering Place. Plants whose natural requirements are appropriate for this climate will reduce or eliminate the need for watering. As well, opportunities for rainwater collection could be revisited during the Design Development process.

Additional initiatives that are proposed include:

- Space allocated for implementation of a recycling program
- Specification of local and regional materials
- Reduction of solar heat gain due to window specification
- Access to daylighting reducing the required lighting load
- Specification of low flow faucets, toilets and urinals for water conservation
- LED light fixtures and site lighting that is sensitive to light pollution

5.0 STRUCTURAL SYSTEMS

GENERAL

The proposed Gathering Place is located at the University of Alberta and connects to the north end of the existing Education Building. The facility essentially consists of a two storey building with a partial basement, and includes a great hall, exhibit areas, common areas, classrooms, meeting rooms and offices. The primary goal of the design is to provide an efficient and aesthetically pleasing structure which contributes to the overall architecture of the building.

STANDARDS

The schematic structural design is based on the following standards:

Alberta Building Code 2006
 Design of Concrete Structures CSA A23.3-04
 Engineering Design in Wood CSA O86-05
 Limit States Design of Steel Structures CAN/CSA S16-01

DESIGN CRITERIA

The building will be designed for the following load conditions specified in the Alberta Building Code:

Snow Loads

$S_s = 1.7 \text{ kPa}$	}	+ snow accumulation where required
$S_r = 0.1 \text{ kPa}$		

Live Loads

Ground and Lower Floor Level 4.8 kPa including partitions
 Mechanical Rooms 3.6 kPa plus unit weights
 Corridors/Exits/Stairs 4.8 kPa

Seismic

$S_a (0.2) = 0.12 \text{ g}$
 $S_a (0.5) = 0.06 \text{ g}$
 $S_a (1.0) = 0.02 \text{ g}$
 $S_a (2.0) = 0.01 \text{ g}$
 PGA = 0.06 g

Wind

$q_{1/50} = 0.45 \text{ kPa}$
 $q_{1/10} = 0.32 \text{ kPa}$

Importance Category

Normal ($I = 1.0$ typically)

- 1. CONCRETE COLUMNS
- 2. CONCRETE BEAMS
- 3. CONCRETE FLOOR
- 4. CONCRETE SHEAR WALL
- 5. CONCRETE STAIR
- 6. GLULAM COLUMNS
- 7. GLULAM BEAMS
- 8. GLULAM VERTICAL MULLIONS
- 9. LAMINATED WOOD DECK
- 10. STEEL BEAMS
- 11. STEEL SUPPORT AT DRUM

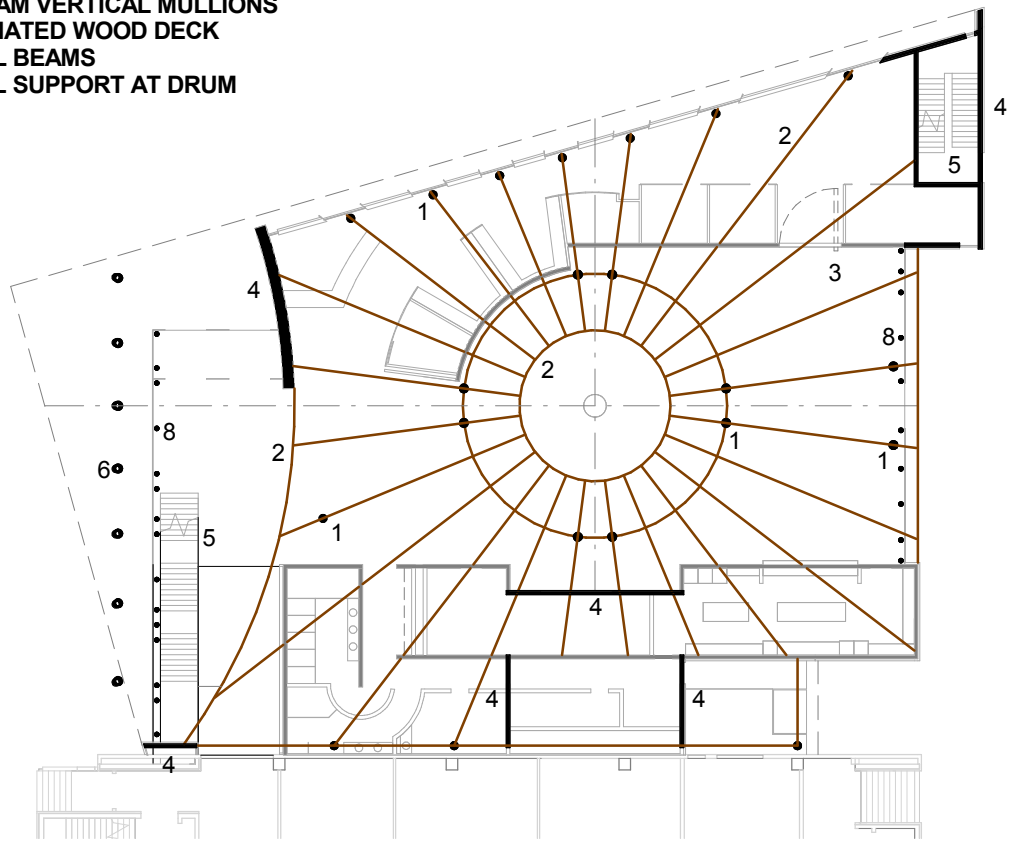

LEVEL TWO - STRUCTURAL FRAMING

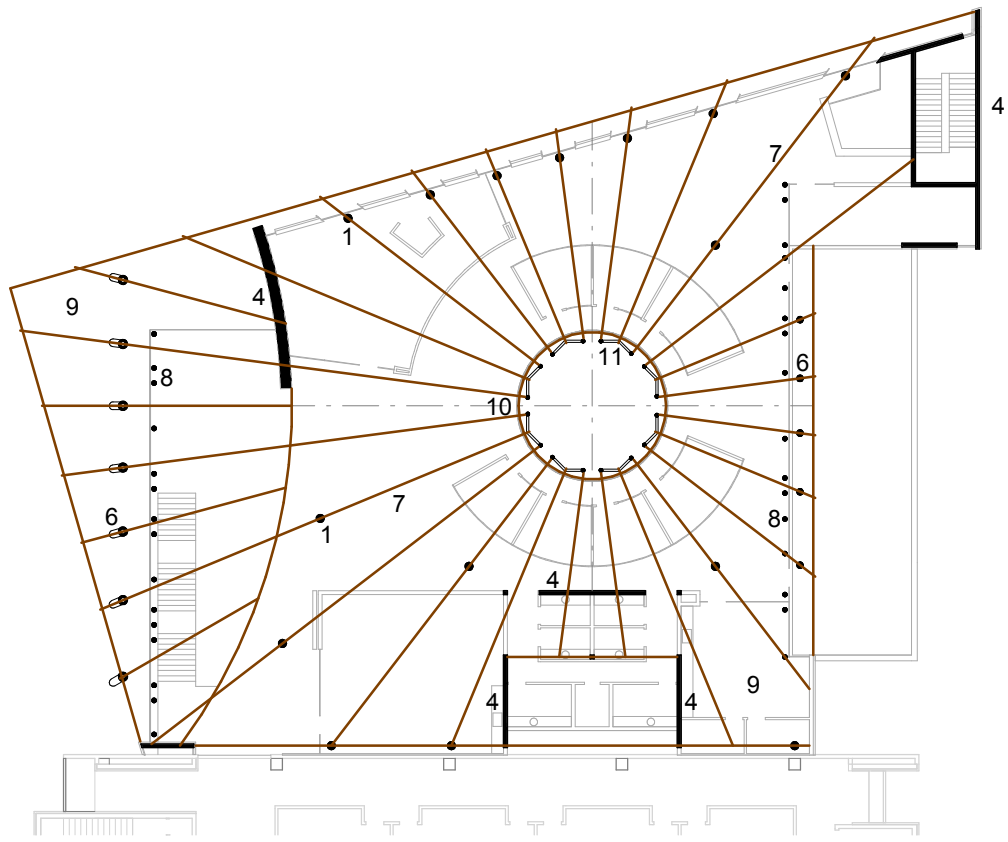

ROOF - STRUCTURAL FRAMING

BUILDING DESCRIPTION

Foundations

A site specific geotechnical report has not been commissioned at this stage. The existing drawings for the adjacent buildings indicate that the Education Building is supported on piled foundations and that the LRT Station just north of the site contains a deep substructure. Based on this information, we would anticipate a piled foundation system for this project.

Main Superstructure

Inspiration for the radial superstructure was drawn from the strong circular form of the Drum in the center of the building.

The roof structure comprises 130mm deep Douglas Fir solid glue-laminated timber (GLT) panels spanning between pairs of 570mm deep Douglas Fir glue-laminated (glulam) beams arranged in a radial layout around the central drum. The small gap between the pairs of glulam beams provides a discrete opportunity to conceal conduits and other services, thereby reducing the “clutter” in the ceiling space. The required thickness of the GLT panels and the glulam beams also offer an inherent 45 minute fire resistance rating to the roof structure.

The raised clerestory roof structure over the central drum is a hybrid of radial glulam beams assisted by steel kingposts and cables, which metaphorically speaks to the tensile construction of a ceremonial

drum. The raised roof will be supported vertically and laterally by diagonal steel columns around the perimeter which extend down to the upper floor level.

The upper floor construction comprises a 200mm concrete slab spanning between 700mm deep concrete beams, spaced in a radial fashion similar to the roof beams above. The concrete cover to the embedded reinforcement provides an inherent 2 hour fire resistance rating to the entire ceiling space.

The lower floor construction over the partial basement consists of a simple reinforced concrete suspended slab. The remainder of the footprint will either be a reinforced concrete suspended slab supported on grade beams and piles or a slab-on-grade, depending on the recommendations in the future geotechnical report.

Columns throughout the building essentially comprise circular concrete columns ranging in size from 350mm to 400mm diameter, depending on location. The exterior columns supporting the west edge of the roof are circular 350mm diameter heavy timber columns set on concrete pedestals.

Lateral Force Resisting System

The primary means of lateral support for the building is provided by 250mm thick cast-in-place reinforced concrete shear walls located within the current architectural layout.

6.0 MECHANICAL SYSTEMS

INTRODUCTION

The purpose of this report is to document the key aspects of the mechanical systems proposed for the Gathering Place at University of Alberta.

CODES AND STANDARDS

The mechanical design shall comply with the most current version of the following codes and industry standards:

- Alberta Building Code (ABC)
- National Plumbing Code (NPC)
- Alberta Fire Code
- National Fire Protection Association (NFPA)
- Canadian Standards Association Standards (CSA)
- Workers' Compensation Board Regulations
- Local building bylaws
- American Society of Heating, Refrigerating and Air Conditioning Engineers Inc. (ASHRAE)
- American Society of Plumbing Engineers (ASPE)
- Sheet Metal and Air Conditioning Contractors National Association (SMACNA)
- University of Alberta Design Guidelines

DESIGN CRITERIA

Outdoor Design Condition

	Outdoor Design Temperature
Summer	28°C DB/19°C WB (July 2.5% ABC)
Winter	-34°C (January 1% ABC)

Indoor Design Condition

	Indoor Design Temperature
Summer	23°C
Winter	22°C

Ventilation Rates

- The space ventilation requirements will be determined in accordance with ASHRAE 62.1-2010 Ventilation for Acceptable Indoor Air Quality.

PLUMBING SYSTEMS

Domestic Water Systems

- The domestic cold water system will be connected to existing water main in basement service corridor. The availability of water service will be further confirmed.
- Domestic hot water will be generated by a steam to water hot water generator located in the basement mechanical room. The hot water generator is a pre-engineered, pre-assembled hot water tank with a steam to water tube bundle heating element. The option of utilizing steam water heater and storage tank, similar to PVI COBREX® steam water heater with a double-wall, copper tube, counter-flow heat exchanger and storage tank, will be considered. A domestic hot water recirculation system with a circulation pump will be designed to maintain adequate hot water supply to all plumbing fixtures.
- All domestic cold, hot and recirculation piping will be copper piping with thermal insulation. Domestic cold and hot piping will be extended to all fixtures. Piping distribution system will be complete with individual fixture isolation valves or fixture group isolation valves as required.

Sanitary Drainage and Vent Systems

- A system of sanitary drainage and venting will collect sanitary waste from plumbing fixtures throughout the building and discharge to the municipal sewage system.
- Floor drains will be provided in washroom, janitor room, kitchen, mechanical room, etc. as per code. Grease interceptor will be provided for kitchen pre-wash sinks.

Storm Drainage System

- Storm water will be collected from roof drains and piped to municipal storm water system.

Natural Gas System

- Natural gas will be distributed to gas-fired equipment throughout the building through steel piping system. Pressure regulators will be provided as required. The gas service connection will be further confirmed.

Plumbing Fixtures

- Plumbing fixtures will be low water consumption commercial grade, CSA approved, and consistent with program requirements. All fixtures will be installed as indicated in the architectural plans.
- Water closets and urinals will be specified with sensor operated hardwired low flow flushometer.
- Lavatories will be equipped with sensor operated hardwired low flow faucet.
- Barrier free fixtures will be provided as required.

HVAC SYSTEMS

Air Systems

Option 1 (Refer to MSK-01 Preliminary Mechanical Room Layout)

Level 1 Great Hall and Lobby Area (AHU-1)

Great Hall and Lobby area will be supplied with conditioned air from an indoor air handling unit located in the basement mechanical room. The unit will be equipped with supply fan and return fan with variable frequency drives, glycol heating coil, cooling coil, mixed air section, steam grid humidifier and air filters. The use of heat recovery wheel will be further reviewed.

Supply air distribution ductwork and diffusers will run overhead. Air supplied to each space will vary according to the demand from space temperature sensor to control variable air volume (VAV) terminal boxes.

Demand-controlled ventilation by the use of CO2 sensors will be designed to modulate the outdoor air damper to maintain space CO2 level.

Level 1 Administration and Level 2 Area (AHU-2)

An indoor make-up air unit with fan coil units system will be designed for space heating, cooling and ventilation for Level 1 Administration

and Level 2 area. The make-up air unit, located in the basement mechanical room, will consist of supply fan and return fan with variable frequency drives, glycol pre-heat coil, heat recovery wheel, glycol re-heat coil, cooling coil, steam grid humidifier and air filters.

Each fan coil units will be equipped with heating coil and cooling coil to maintain space temperature. Outside air will be ducted to return air duct of individual fan coil units. The fan coil units serving Level 1 Administration area will be located in the ceiling space. Conditioned air will be distributed through ceiling mounted diffusers. The fan coil units serving Level 2 will be located in the access floor space. Conditioned air will be distributed through floor mounted displacement diffusers.

Demand-controlled ventilation by the use of CO2 sensors will be designed to modulate the VAV boxes in the outside air duct to maintain space CO2 level.

Option 2

Level 1 and Level 2 (AHU-1)

The building will be supplied with conditioned air from an indoor air handling unit located in the basement mechanical room. The unit will be equipped with supply fan and return fan with variable frequency drives, glycol heating coil, cooling coil, mixed air section, steam grid humidifier and air filters. The use of heat recovery wheel will be further reviewed.

KEYNOTES:

- 1 SHELL & TUBE STEAM TO HEATING WATER HEAT EXCHANGER HX-1
- 2 SHELL & TUBE STEAM TO GLYCOL HEAT EXCHANGER HX-2
- 3 HEATING WATER PUMPS P-1 & P-2
- 4 GLYCOL HEATING WATER PUMPS P-3 & P-4
- 5 CHILLED WATER PUMPS P-5 & P-6
- 6 CONDENSATE TANK/PUMP CR-1
- 7 DOMESTIC HOT WATER GENERATOR DWH-1
- 8 DOMESTIC HOW WATER EXPANSION TANK TK-3
- 9 GLYCOL FILL TANK TK-4
- 10 GLYCOL HEATING WATER EXPANSION TANK TK-2
- 11 HEATING WATER EXPANSION TANK TK-1
- 12 CONTROL PANELS
- 13 ELECTRICAL PANELS

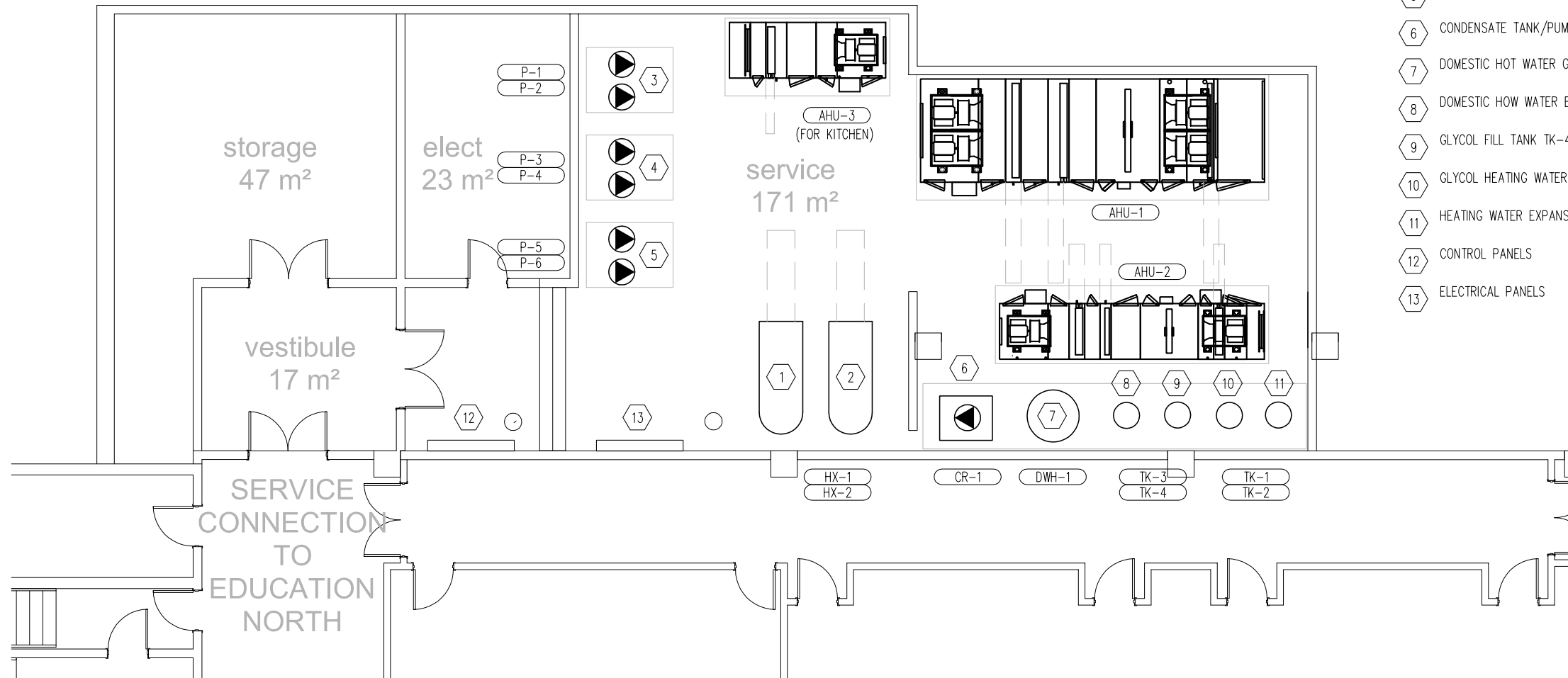

PRELIMINARY MECHANICAL ROOM LAYOUT (OPTION 1)

Air supplied to each space will vary according to the demand from space temperature sensor to control variable air volume (VAV) terminal boxes. The VAV boxes serving Level 1 will be located in the ceiling space. Conditioned air will be distributed through ceiling mounted diffusers. The VAV boxes serving Level 2 will be located in the access floor space. Conditioned air will be distributed through floor mounted displacement diffusers.

Demand-controlled ventilation by the use of CO₂ sensors will be designed to modulate the outdoor air damper to maintain space CO₂ level.

Kitchen

A dedicated exhaust fan and make-up air unit will be provided as required. Kitchen exhaust fan will be located on roof and the make-up air unit will be located in the basement mechanical room.

Heating Systems

A steam to water shell and tube heat exchanger will deliver heating water to fan coil units, force flows, unit heaters, radiation/radiant panels and radiant in-floor heating throughout the building for space heating. Two heating water circulation pumps sized at 50% of the system capacity each will be designed. Variable frequency drives will be provided for heating water pumps.

A steam to glycol shell and tube heat exchanger will be designed to provide glycol heating water to heating coils in the air handling units AHU-1 & AHU-2. Two glycol heating circulation pumps sized at 50% of the system capacity each will be designed. Variable frequency drives will be provided for glycol heating pumps.

Hydronic Force flows will be provided in vestibules and entrances.

Loading dock corridor will be equipped with a hydronic unit heater.

In-Floor radiant heating system will be provided in Level 1 Great Hall and Lobby Area and this will allow air system to be shut down during unoccupied period where applicable.

The steam and condensate piping for shell and tube heat exchangers will be connected to the U of A central steam and condensate system in basement service corridor. The availability of existing steam and condensate services will be further confirmed.

Cooling Systems

Chilled water for cooling coils in air handling units AHU-1 & AHU-2, and fan coil units will be supplied from the U of A central chilled water system in basement service corridor. The existing chilled water flow rate will be further confirmed. Two chilled water circulation pumps sized at 50% of the system capacity each will be designed. Variable frequency drives will be provided for chilled water pumps.

Server room will be equipped with a 2-pipe fan coil unit or ductless split air conditioning unit for space cooling depending on heat dissipation load and requirement for redundancy.

Humidification Systems

Steam dispersion unit will be provided in air handling units AHU-1 and AHU-2 to maintain space relative humidity level. Steam will be provided by central steam plant.

PRELIMINARY EQUIPMENT LIST (OPTION 1)

Unit No.	Unit Description	Manufacturer	Equipment Information
AHU-1	Air Handling Unit – Level 1 Great Hall and Lobby Area	Trane/EngA	Indoor unit c/w supply fan (with VFD), return fan (with VFD), glycol heating coil, cooling coil, mixed air section, steam grid humidifier section and filter sections. The requirement of heat recovery wheel to be further confirmed. S/A: 5000 l/s R/A: 5000 l/s Glycol Heating Coil: 150 kW Cooling Coil: 90 kW
AHU-2	Air Handling Unit – Level 1 Administration and Level 2 Area	Trane/EngA	Indoor unit c/w supply fan (with VFD), return fan (with VFD), glycol pre-heat coil, heat recovery wheel, glycol re-heat coil, cooling coil, steam grid humidifier section and filter sections S/A: 1200 l/s R/A: 1200 l/s Glycol Pre-heat Coil: 40 kW Glycol Re-heat Coil: 30 kW Cooling Coil: 20 kW
DWH-1	Domestic Hot Water Generator	A.O. Smith	Steam to water hot water generator
HX-1	Heat Exchanger	Armstrong/Bell & Gossett	Shell and tube heat exchanger, steam to water
HX-2	Heat Exchanger	Armstrong/Bell & Gossett	Shell and tube heat exchanger, steam to glycol
P-1/P-2	Heating Water Pump	Armstrong/Bell & Gossett	Vertical In-line
P-3/P-4	Glycol Heating Pump	Armstrong/Bell & Gossett	Vertical In-line
P-5/P-6	Chilled Water Pump	Armstrong/Bell & Gossett	Vertical In-line
P-7	Domestic Hot Water Recirc. Pump	Armstrong/Bell & Gossett	In-line circulator
CR-1	Condensate Recovery Unit	Spirax Sarco	Condensate tank and pump
TK-1	Heating Water Expansion Tank	Armstrong/Bell & Gossett	Diaphragm type expansion tank
TK-2	Glycol Heating Expansion Tank	Armstrong/Bell & Gossett	Diaphragm type expansion tank

TK-3	Domestic Hot Water Expansion Tank	Armstrong/Bell & Gossett	Diaphragm type expansion tank
FC	Fan Coil Units	EngA	Level 1 Administration and Level 2 Area. Unit c/w direct drive motor and variable speed controller.

FF	Force Flows	Trane/EngA	Vestibule and Stair
UH	Unit Heater	Trane/EngA	Loading Dock
VAV	VAV Boxes	EH Price/Titus	
	Radiant In-floor Heating	Heatlink/Uponor	Level 1 Great Hall and Lobby Area
	Radiation/Radiant Panel	Trane/EngA	
	Grille/Diffuser/Louver	E.H. Price/Titus	
	CO2 Sensors		

FIRE PROTECTION SYSTEMS

The building will be fully sprinklered to meet the requirements of NFPA 13 and the latest building code. The sprinkler system will be a wet pipe quick response system. Dry pipe system will be provided for locations where potential freeze conditions are possible.

The sprinkler system will be connected to existing fire protection water main in basement service corridor. The system water flow rate and pressure will be further confirmed.

Dry chemical fire extinguishers will be provided throughout the building as required by NFPA 10.

FIRE DAMPERS AND FIRE STOPPING

All ducts and piping passing through a fire separation will be provided with fire stopping in accordance with the building codes. Any ducts passing through a fire separation will be provided with an approved fire damper.

THERMAL INSULATION

Piping, equipment and sheet metal work with surface temperatures greater or less than surrounding air temperature will be insulated to control heat transfer and condensation.

Insulation on piping systems will include:

- Heating water/glycol

- Chilled water
- Steam and condensate
- Domestic hot, cold and recirculation
- Roof drains and a three (3) metre pipe distance from the roof drain
- Plumbing vents within three (3) metre pipe distance from the roof outlet

Insulation of duct systems will include:

- Outside air ducts/plenums
- Supply ducts carrying conditioned air
- Exhaust/relief ducts within three (3) metre duct distance from exterior walls or openings

SOUND AND VIBRATION CONTROL

The Noise Criteria (NC) levels recommended by ASHRAE will be achieved in all areas. Careful consideration will be given to isolate the rotating equipment. Acoustic insulation will be utilized where required to prevent duct borne noise and reduce radiated sound levels.

CONTROLS

The building will be complete with a DDC control system. The control system will be fully software programmable and accessible on site through a local terminal and off site via internet.

The DDC system will monitor and control the HVAC systems, domestic hot water system, space temperature, humidity, CO₂, etc., with alarm functions.

7.0 ELECTRICAL SYSTEMS

INTRODUCTION

The following is a description of the electrical systems that are proposed for use within The Gathering Place facility, located on the University of Alberta campus. The electrical systems for The Gathering Place will be designed to meet the needs of a modern and energy efficient facility.

The electrical design will be based on the latest editions of the Alberta Building Code, the Canadian Electrical Code, the National Energy Code of Canada for Buildings, and IESNA guidelines. The electrical design will also follow University of Alberta standards, published and observed.

DESIGN CRITERIA: POWER DISTRIBUTION SYSTEM

The main service will originate from the existing Education North building. A service connection in the basement between buildings has been designed to accommodate the connection.

The existing Education North building will feed the new Gathering Place main distribution panel (MDP) estimated to be rated at 200 amp, 600/347 volt, 3 phase, four wire. The MDP will have the following features:

Digital "Power Information Meter" to provide real time information on the power system and to record maximum and minimum loads on the service. [Note: a utility meter will not be required.]

Spare capacity of 15-30% for future increased power demands.

Sub distribution panels will be provided to power smaller loads such as lights, convenience receptacles and small motors. Distribution will include high efficiency dry type transformers to transform the voltage to 120/208V.

Surge suppression/lightning protection will be provided on the main electrical service and individual panels with the sensitive electronic equipment.

GROUNDING

A complete grounding system will be installed in accordance with the Canadian Electrical Code and good engineering practice.

CONDUIT AND WIRE

Wiring will typically be installed in conduits. Electrical metallic tubing (EMT) will be used throughout the building except where subject to mechanical injury. Conduits are to be installed concealed except in mechanical and electrical rooms where it may be installed exposed. Seal-tight flexible conduit shall be used for final connections to

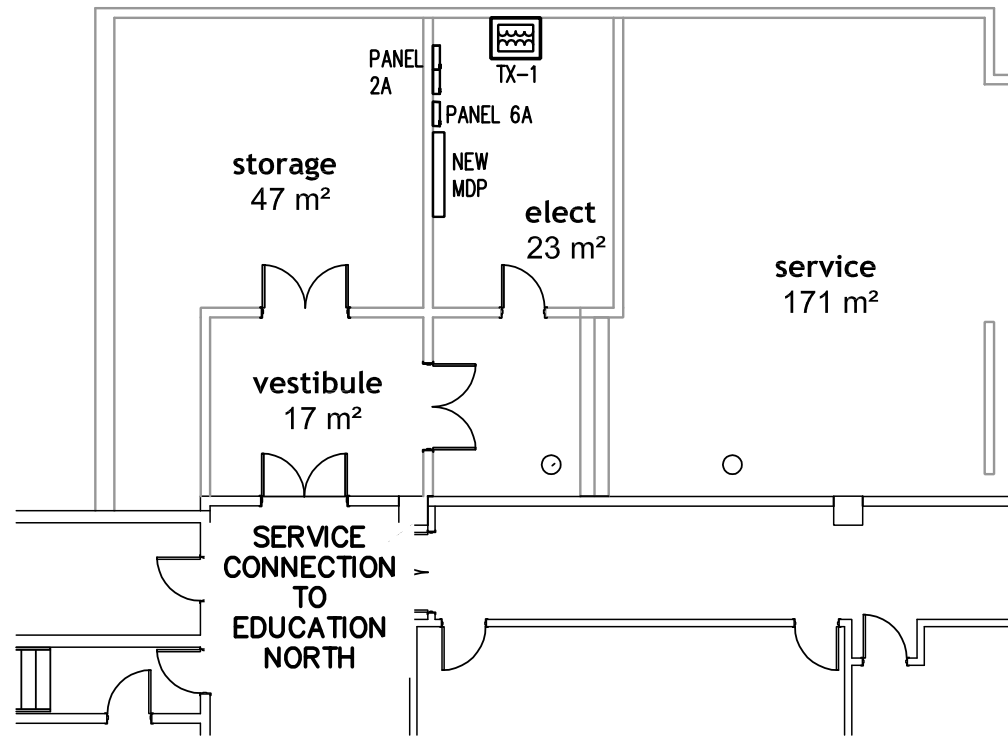

BASEMENT ELECTRICAL ROOM LAYOUT

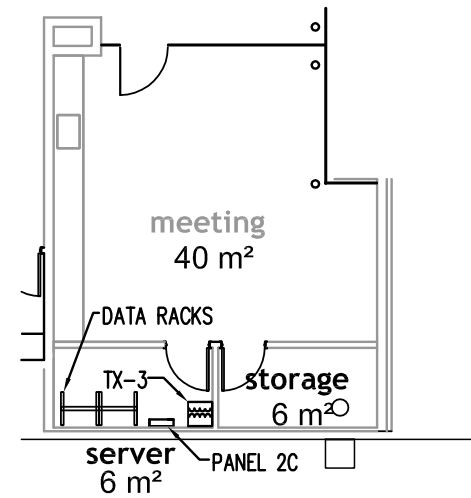

SECOND FLOOR SERVER / ELEC. ROOM LAYOUT

motors, and BX-type cable shall be used for final connections to light fixtures, in demountable partitions, and within steel stud wall assemblies.

All building wire shall be with 600 volt insulation. Minimum size shall be #12 AWG for branch circuit wiring. All wiring will be colour coded, complete with permanent markers. All conductors will be copper.

DEVICES

Duplex receptacles will be specification grade with permanent markers indicating circuit numbers. All receptacles in the open areas will be child tamper proof.

Convenience outlets will be installed as integral part of the facility. Floor boxes will be used as necessary to service exhibits and allow for future flexibility.

Receptacles will be provided for specific systems as they are identified during the design process. Such systems may be exhibit specific power requirements, as well as classroom and programming area system requirements.

The kitchen area will be supplied with receptacles and with hardwired connections to required equipment.

LIGHTING SYSTEM

The building interior lighting at the schematic design stage is for high level uniform lighting.

Energy efficient lighting systems will be used throughout the facility to achieve a maximum overall consumption of 13 W/m². High Level Overall uniform lighting that achieves on average 300 lx horizontal at about 0.7m above the floor will be designed for office and classroom areas; lighting levels in the great hall will be established in detailed design to achieve the requirements for the ceremonial nature of the space.

Lighting levels will conform to established standards (IESNA). A combination of LED and fluorescent fixtures will mainly be used.

In the great hall as well as lobby and circulation spaces, pendant mounted LED cylindrical fixtures will be used to provide uniform lighting. Exhibit specific lighting will provide light directed at the locations required. Directional or track LED fixtures will be used in these areas to provide directional lighting with the flexibility for changing exhibits.

Direct/indirect fixtures will be used to provide high quality lighting. 2x4 direct/indirect T5 or T8 fluorescent fixtures, recessed in the T-bar ceiling will be provided in offices, classroom, and programming areas.

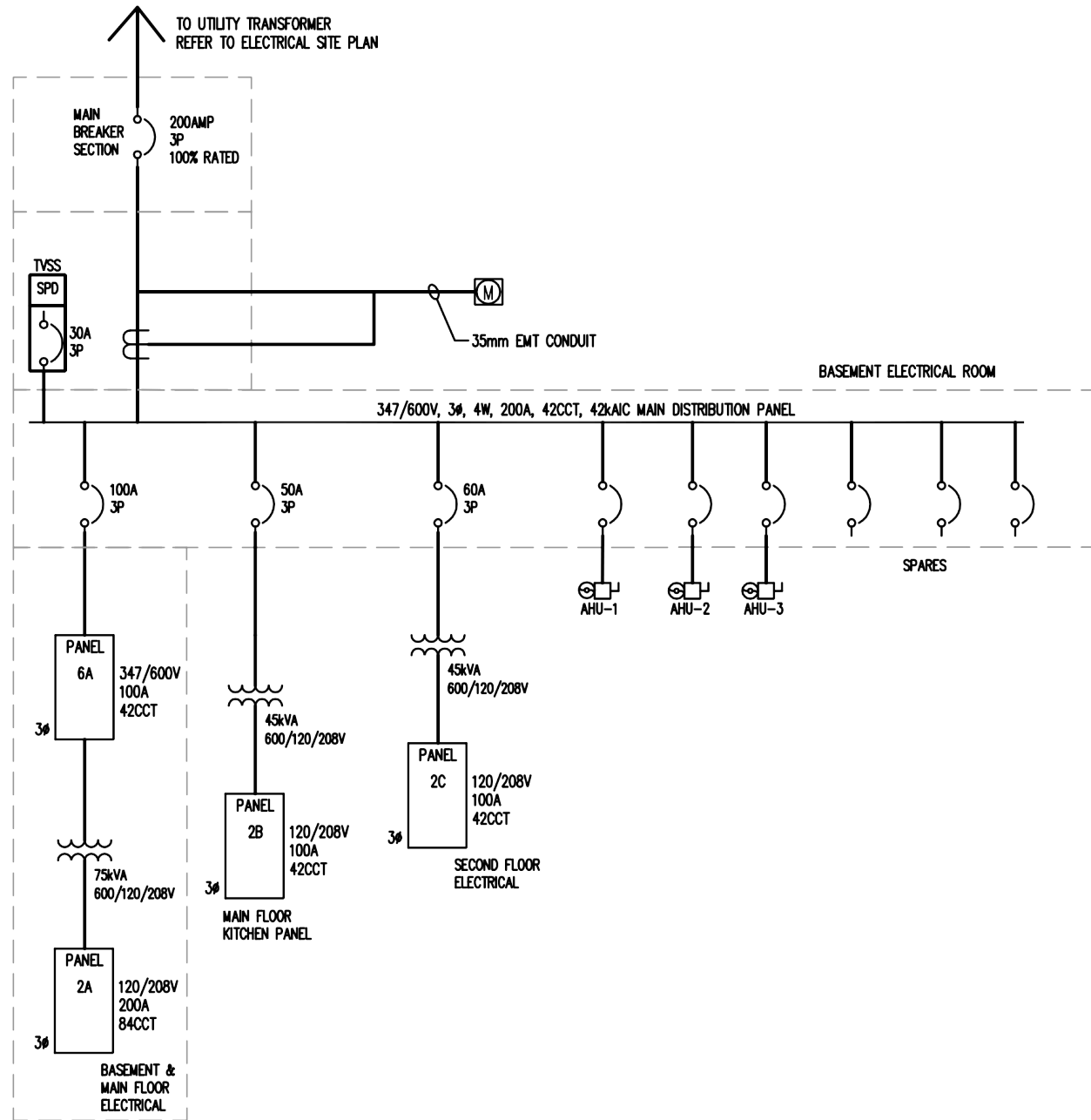

PRELIMINARY SINGLE LINE DIAGRAM

All luminaires will be controlled via a digital lighting control system. Lighting in common areas and work areas will be controlled by the occupancy sensors with daylight sensor overrides or manual overrides. A control panel with multiple scene selection will be provided for the Great Hall. Washrooms, storage rooms, and other typically unoccupied rooms will be controlled via occupancy sensors only.

EXTERIOR LIGHTING

Each entrance will have wall-mounted or under-canopy metal halide or LED type fixture with decorative lighting provided for the major walkways. All exterior lighting will be on photocell, time clock, and hand-off-auto bypass control, integrated with and provided by the main building digital lighting control system.

EMERGENCY LIGHTING

Emergency lighting will be provided throughout the facility to conform to the requirements of the Alberta Building Code. It will likely be provided through selected luminaires using emergency ballasts installed in the fixtures.

Illuminated LED-type exit signs will be provided throughout the facility to conform to the requirements of the Alberta Building Code.

TELEPHONE SYSTEM AND BUILDING SERVICE

The telephone service for this facility will originate from the service connection with the existing Education North Facility.

All telephones will be using VoIP technology with the exception of dedicated phone lines for fax machines, security, and fire alarm system.

VoIP telephones will work using the data network cabling (category 6) thus there will be no requirement separate for the cabling system for telephones. Hardwired phones (fire alarm monitoring) will require cat 3 cabling run directly to BIX terminals on the telephone board.

DATA CABLING SYSTEM

A complete LAN cabling system will be provided using category 6 cabling. Terminations racks with patch panels (floor-mounted) in the communications room.

Data outlets (8P8C jacks) will be provided throughout the facility.

Data cabling will be used for powering equipment using small loads (phones, speakers, and wireless access points) using PoE technology.

FIRE ALARM SYSTEM

Fire Alarm System will be single stage, addressable, and will conform to the requirements of the Alberta Building Code and the local fire fighting authorities.

The system will have the following features:

Automatic alarm initiating devices (smoke detectors, heat detectors).

Manual alarm initiating devices (pull stations) throughout the facility.

Signaling devices (horn/strobes) throughout the facility.

Supervision of the sprinkler system including valve temper supervision and water flow alarms.

Connections to mechanical systems for an emergency shut-down.

The system will be integrated with Education North and the campus network.

SECURITY SYSTEM

Rough-ins for security system will be provided in close cooperation with the University of Alberta security department and will include the following:

Reserved space on the walls in the communication room for the security equipment.

Rough-ins for motion sensors in corridors, and open areas.

Rough-ins for door contacts at all exterior doors and operable windows

Rough-ins for keypads and proximity readers at entrance locations and selected doors.

Rough-ins for security cameras will be provided throughout the facility.

PUBLIC ADDRESS (PA) SYSTEM

Rough-ins for the public address system will be provided with close cooperation with the University of Alberta's preferred supplier.

AUDIOVISUAL EQUIPMENT

Cabling infrastructure for a ceiling mounted projector's or SMART boards will be provided in the program room, classroom, meeting room and other rooms as required. The infrastructure will contain power and data connection to the projector/SMART board and enclosed wall/floor cabling (VGA, HDMI, and component)

Cabling for connection to the LCD display screen(s) in designated open areas will be provided as required.

ENERGY CONSERVATION

The electrical systems for the building will be designed to achieve high energy efficiency. The lighting systems design will take into account daylighting opportunities and make use of recent advances in energy efficient fixtures.